

Memorex[®]

MVR4051 Series A

SERVICE MANUAL

VIDEO CASSETTE RECORDER

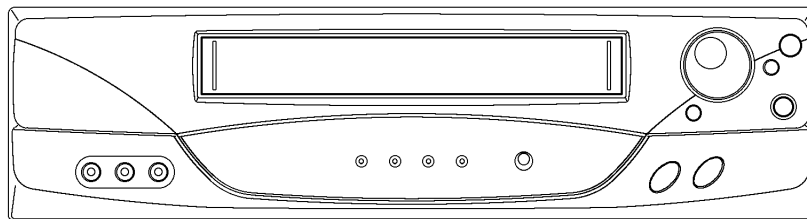

VHS

**ORIGINAL
MFR'S VERSION B**

SERVICING NOTICES ON CHECKING

1. KEEP THE NOTICES

As for the places which need special attentions, they are indicated with the labels or seals on the cabinet, chassis and parts. Make sure to keep the indications and notices in the operation manual.

2. USE THE DESIGNATED PARTS

The parts in this equipment have the specific characters of incombustibility and withstand voltage for safety. Therefore, the part which is replaced should be used the part which has the same character.

Especially as to the important parts for safety which is indicated in the circuit diagram or the table of parts as a  mark, the designated parts must be used.

3. PUT PARTS AND WIRES IN THE ORIGINAL POSITION AFTER ASSEMBLING OR WIRING

There are parts which use the insulation material such as a tube or tape for safety, or which are assembled in the condition that these do not contact with the printed board.

The inside wiring is designed not to get closer to the pyrogenic parts and high voltage parts. Therefore, put these parts in the original positions.

4. PERFORM A SAFETY CHECK AFTER SERVICING

Confirm that the screws, parts and wiring which were removed in order to service are put in the original positions, or whether there are the portions which are deteriorated around the serviced places serviced or not. Check the insulation between the antenna terminal or external metal and the AC cord plug blades. And be sure the safety of that.

HOW TO ORDER PARTS

Please include the following informations when you order parts. (Particularly the VERSION LETTER.)

1. MODEL NUMBER and VERSION LETTER

You can find it in the back of your unit.

2. PART NO. and DESCRIPTION

You can find it in your SERVICE MANUAL.

CONTENTS

SERVICING NOTICES ON CHECKING	A1-1
HOW TO ORDER PARTS	A1-1
CONTENTS	A2-1
GENERAL SPECIFICATIONS	A3-1~A3-4
DISASSEMBLY INSTRUCTIONS	
1. REMOVAL OF MECHANICAL PARTS AND P. C. BOARDS	B1-1
2. REMOVAL OF DECK PARTS	B2-1~B2-6
3. REMOVAL AND INSTALLATION OF FLAT PACKAGE IC	B3-1, B3-2
KEY TO ABBREVIATIONS	C1-1, C1-2
SERVICE MODE LIST	C2-1
PREVENTIVE CHECKS AND SERVICE INTERVALS	C3-1
SERVICING FIXTURES AND TOOLS	C4-1
PREPARATION FOR SERVICING	C4-1
MECHANICAL ADJUSTMENTS	D1-1~D1-4
ELECTRICAL ADJUSTMENTS	D2-1, D2-2
BLOCK DIAGRAMS	
Y/C/AUDIO/CCD/HEAD AMP	E-1, E-2
SYSTEM CONTROL/SERVO	E-3, E-4
TUNER	E-5, E-6
HI-FI/DEMODULATOR	E-7, E-8
OPERATION/POWER	E-9, E-10
PRINTED CIRCUIT BOARDS	
SYSCON/OPERATION	F-1 ~ F-4
SCHEMATIC DIAGRAMS	
Y/C/AUDIO/CCD/HEAD AMP	G-1, G-2
SYSTEM CONTROL/SERVO	G-3, G-4
POWER	G-5, G-6
OPERATION	G-7, G-8
TUNER	G-9, G-10
HI-FI/DEMODULATOR	G-11, G-12
INTERCONNECTION DIAGRAM	G-13, G-14
WAVEFORMS	H-1
MECHANICAL EXPLODED VIEW	I-1
CHASSIS EXPLODED VIEWS	I-2, I-3
MECHANICAL REPLACEMENT PARTS LIST	J1-1
CHASSIS REPLACEMENT PARTS LIST	J2-1
ELECTRICAL REPLACEMENT PARTS LIST	J3-1

GENERAL SPECIFICATIONS

G-1	VCR System	System		VHS Player / Recorder	
		Video System		NTSC	
		Hi-Fi STEREO		Yes	
		NTSC PB(PAL60Hz)		No	
		Deck	DECK Loading System Motor	OVD-7 Front 3	
		Heads	Video Head	4Head	
			FM Audio Head	2Head	
			Normal Audio /Control	Mono / Yes	
			Erase(Full Track Erase)	Yes	
		Tape	Rec	PAL	
		Speed		NTSC	
			Play	PAL	
				NTSC	
			Fast Forward / Rewind Time (Approx.)	FF:4'50"/REW:2'30"	
				with Cassette	
			Forward/Reverse	NTSC or PAL-M	
	Picture Search	PAL or SECAM			
	Frame Advance	Slow			
	Slow Speed	Variable Slow			
G-2	Tuning System	Broadcasting System		US System M	
		Tuner and	System	1Tuner	
		Receive CH	Destination	USA(w/CATV)	
			Tuning System	F-Synth	
			Input Impedance	VHF/UHF 75 OHM	
			CH Coverage	2-69,4A,A-5~ A-1,A-1,J- W W+1-W+84	
		Intermediate	Picture(FP)	45.75MHz	
		Frequency	Sound(FS)	41.25MHz	
			FP-FS	4.50MHz	
			Preset CH	No	
			RF Converter Output	Yes	
			Channel	3 or 4 ch	
	Level/Impedance	66dBu /75ohm			
	Sound Selector	No			
	Stereo/Dual TV Sound	Yes			
G-3	Power	Power Source	AC DC	120V,60Hz -	
		Power Consumption	Power On(at AC) Stand by (at AC) Per Year	9W at 120V 60Hz 1.8W at 120V 60Hz - kWh/Year	
		Protector	Power Fuse Dew Sensor	Yes No	
G-4	Signal	Video Signal	Input Level Output Level S/N Ratio (Weighted) Horizontal Resolution at SP Mode	1 V p-p/75 ohm 1 V p-p/75 ohm 50 230Line	
		Audio Signal (0dB=0.775Vrms)	Input Level Output Level S/N Ratio at SP (Weighted) Harmonic Distortion (1KHz) Frequency Response at SP at LP at SLP	-8dB/50Kohm -8dB/1Kohm 42dB 1.5% 100Hz - 10kHz 100Hz - 6kHz 100Hz - 4kHz	
		Hi-Fi Audio Signal	Dynamic Range : More than Frequency Response Wow And Flutter : Less than Channel Separation : More than Harmonic Distortion : Less than	90dB 20Hz ~20kHz 0.01 %Wrms 60 dB 0.01	
		G-5	Interface	Switch	Front
					No
					No
					No
	Rear			RF Output SW	Yes

GENERAL SPECIFICATIONS

		Indicator	Power	Yes		
			Stand by	No		
			Rec/OTR	No		
			Repeat	No		
			TV/VCR	Yes		
			Rec	Yes		
			T-Rec	Yes		
			Tape In	No		
			Terminals	Front	Video Input	RCA x 1
					Audio Input	RCA x 2 (Stereo)
			Other Terminal		No	
			Rear	Video Input	No	
				Audio Input	No	
				Video Output	RCA x 1	
Audio Output	RCA x 2 (Stereo)					
Euro Scart	No					
DC Jack 12V(Center +)	No					
VHF/UHF Antenna Input	F Type					
AC Inlet	No					
G-6	Set Size	Approx. W x D x H (mm)	360 x 229 x 95			
G-7	Weight	Net (Approx.)	3.2kg(7.1lbs)			
		Gross (Approx.)	3.8kg(8.4lbs)			
G-8	Regulation	Safety	UL/CSA			
		Radiation	FCC/DOC			
G-9	Temperature	Operation	5oC - 40oC			
		Storage	-20oC - 60oC			
G-10	Operating Humidity		Less then 80% RH			
G-11	On Screen Display	Menu	Yes			
		Menu Type	Character			
		ATS	No			
		Timer Rec Set	Yes			
		Auto Repeat On/Off	Yes			
		SAP On Off	Yes			
		CH Set-Up	TV/CATV	Yes		
			Auto CH Memory	Yes		
		Add/Delete	Yes			
		Pin Code Registration	No			
		System Set-Up	No			
		Clock Set	Yes (Calendar 12H)			
		Language	Yes			
		No Noise Back Ground	Yes			
		G-CODE(or SHOWVIEW or PLUSCODE)No. Entry	No			
		NICAM 1/2,NICAM Off,Audio Output	No			
		Stereo,Audio Output,SAP	Yes			
		Play/Stop/FF/Rew/Rec/OTR/T-Rec/Pause/Eject/Tape In (Symbol Mark)	Yes			
		CH/AV	Yes			
		Clock	Yes			
		Repeat	Yes			
		Pin Code	No			
		Tape Counter	Yes			
		Index	No			
		Hotel Lock	No			
		Tape Speed	Yes			
		Manual Tracking (Bar Setting)	No			
		Hi-Fi	Yes			
		S-Repeat/SR-R/SR-Play	No			
		VPS	No			
		PDC	No			
		G-12	OSD Language	OSD Language Setting	English French Spanish	
	English					
G-13	Display	Indicator	No			
		Indicator Type	-			
		Clock/Counter,CH,Timer Rec,OTR, Play Rec,FF(Cue),Rew(Rev),Stop,ATR	-			
		Pause("Rec"Flash)	-			
		Still("Play"Flush)	-			
		Eject(Tape Mark Flash)	-			
		Slow	-			
		WKL,Y.M.D,Start,End	-			
		AFT	-			
		Repeat	-			
		A-DUB	-			
		VCR	-			
		Memory	-			
		Index	-			
		VPS	-			
PDC	-					

GENERAL SPECIFICATIONS

		SP	-	
		LP	-	
		SLP	-	
		AM	-	
		PM	-	
		F1,F2	-	
		RF Output CH	-	
G-14	Clock,Timer and Timer Back-up	Calendar	1990/1/1 ~ 2081/12/31	
		Timer Events	8 prog/1 month	
		One Touch Recording Max Time	5 Hours	
		OTPB Valid Time	No	
		Timer Back-up (at Power Off Mode)	5 sec.	
G-15	Remote Control	Unit	RC-EA	
		Glow in Dark Remocon	No	
		Power Source	Voltage(D.C) UM size x pcs	3V UM-4 x 2 pcs
		Total Keys		33 Keys
		Keys	Power	Yes
			1	Yes
			2	Yes
			3	Yes
			4	Yes
			5	Yes
			6	Yes
			7	Yes
			8	Yes
			9	Yes
			0	Yes
			CH Up	Yes
			CH Down	Yes
			Input Select	Yes
			Play	Yes
			F.Fwd	Yes
			Rew	Yes
			Pause/Still	Yes
			Stop	Yes
			Rec/OTR	Yes
			Eject	No
			Counter Reset	Yes
			Speed	Yes
			Timer Rec	Yes
			TV Monitor	No
			Quick View	No
			Program	No
			Slow	Yes
			Auto Tracking	Yes
			Set/Tracking+	Yes
			Set/ Tracking -	Yes
			Menu	Yes
			Enter	Yes
			Cancel	Yes
	Call	Yes		
	TV/VCR	Yes		
	Sleep Timer	No		
	Muting	No		
	Clock/Counter	No		
	Zero Return	No		
	CM Skip	No		
	Audio Select	Yes		
G-16	Features	Auto Head Cleaning	Yes	
		Auto Tracking	Yes	
		Index Search	No	
		HQ (VHS Standard High Quality)	Yes	
		Auto Power On, Auto Play, Auto Rewind, Auto Eject	Yes	
		Auto Power Off	Yes	
		Forward/Reverse Picture Search	Yes	
		VIDEO PLUS+(SHOWVIEW,G-CODE)	No	
		ATS	No	
		PDC	No	
		VPS	No	
		One Touch Playback	No	
		Picture Control	No	
		Auto Preset	No	
		Channel Lock	No	
		Hotel Lock	No	
Anti Theft	No			
Audio Dubbing	No			

GENERAL SPECIFICATIONS

		Remort Control Code 1/2	No
		SQPB	No
		CATV	Yes
		Energy Star	Yes
		MTS(SAP)	Yes
		CM Skip(30sec x 6 Times)	No
G-17	Accessories	Owner's Manual Language w/Guarantee Card	English/French Yes
		Remote Control Unit	Yes
		Dew Cation Sheet	No
		Video Cassette Tape	No
		Battery UM size x pcs	-
		Safety Tip	No
		Toll Free Insert Sheet	No
		Quick Set-Up Sheet	No
		Information Sheet (Buyer Supply)	No
		75 Ohm Coaxial Cable	Yes(Single shield)
		Rod Antenna Poles Terminal	No
		Loop Antenna Terminal	No
		U/V Mixer	No
		DC Car Cord (Center+)	No
		Guarantee Card	No
		Warning Sheet	No
		Circuit Diagram	No
		Antenna Change Plug	No
		Service Facility List	No
		Important Safeguard	No
		Dew/AHC Caution Sheet	No
		AC Plug Adapter	No
		Quick Set-up Sheet	No
		AC Cord	No
		AV Cord (2Pin-1Pin)	No
		Registration Card	No
		PTB Sheet	No
		Tape Rewinder(Buyer Supply)	No
		300 ohm to 75 ohm Antenna Adapter	No
		G-18	Carton
Content	-		
Material	-		
Dimensions W x D x H(mm)	-		
Description of Origin	-		
Gift Box	Yes		
Material	Single/White		
Dimensions W x D x H(mm)	420x291x160		
Design	As Per BUYER 's		
Description of Origin	Yes		
Drop Test	Natural Dropping At	1Corner / 3Edges / 6Surfaces	
	Height (cm)	80	
	Container Stuffing(40' container)	3136Sets	
G-19	Cabinet Material	Cabinet Front	PS 94V2 DECABROM

DISASSEMBLY INSTRUCTIONS

1. REMOVAL OF MECHANICAL PARTS AND P.C. BOARDS

1-1: TOP CABINET, FRONT CABINET AND OPERATION PCB (Refer to Fig. 1-1)

1. Remove the 4 screws ①.
2. Remove the Top Cabinet in the direction of arrow (A).
3. Disconnect the following connector: (CP651).
4. Unlock the 7 supports ②.
5. Remove the Front Cabinet in the direction of arrow (B).
6. Remove the 4 screws ③ and remove the Operation PCB.

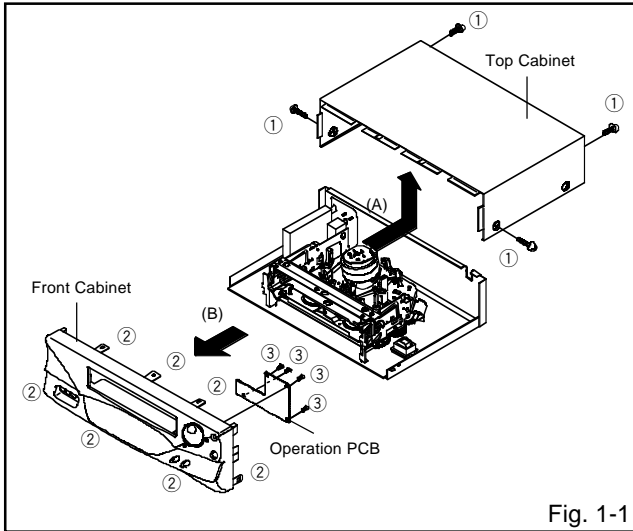

1-2: FLAP (Refer to Fig. 1-2)

1. Open Flap to 90° and flex in direction of arrow (A), at the same time slide in direction of arrow (B).
2. Then lift in direction of arrow (C).

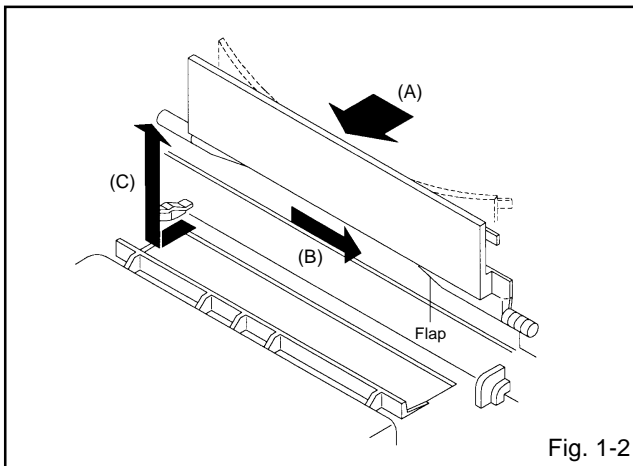

1-3: DECK CHASSIS (Refer to Fig. 1-3)

1. Remove the 3 screws ①.
2. Disconnect the following connectors: (CP1001, CP4001, CP4002 and CP4003).
3. Remove the Deck Chassis in the direction of arrow.

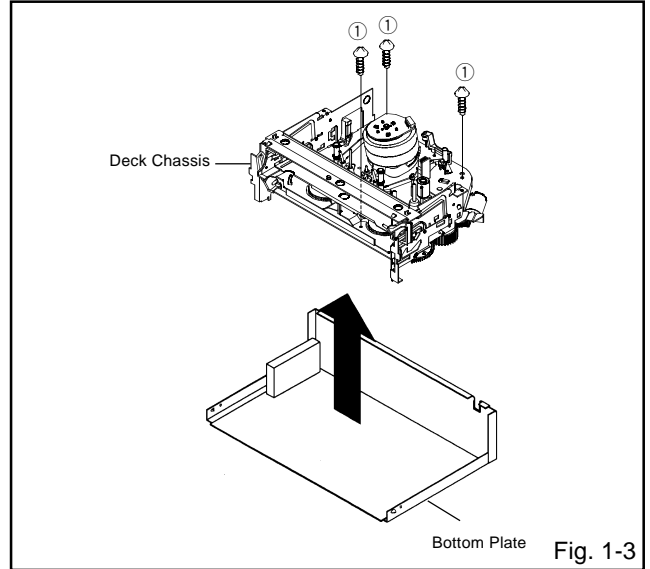

1-4: SYSCON PCB AND JACK PLATE (Refer to Fig. 1-4)

1. Remove the screw ①.
2. Remove the screw ②.
3. Remove the Syscon PCB in the direction of arrow.

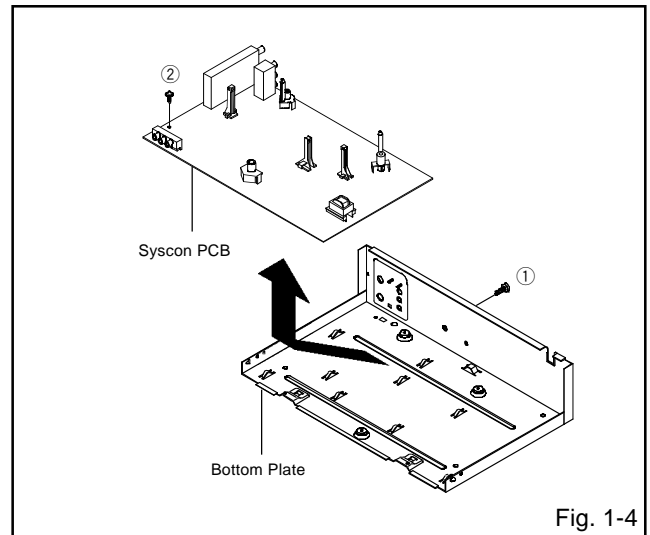

DISASSEMBLY INSTRUCTIONS

2. REMOVAL OF DECK PARTS

2-1: TOP BRACKET (Refer to Fig. 2-1)

1. Extend the 2 supports ①.
2. Slide the 2 supports ② and remove the Top Bracket.

NOTE

1. After the installation of the Top Bracket, bend the support ① so that the Top Bracket is fixed.

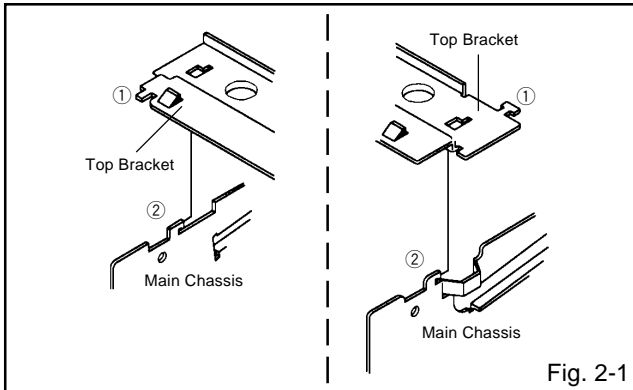

Fig. 2-1

2-2: CASSETTE HOLDER ASS'Y (Refer to Fig. 2-2)

1. Move the Cassette Holder Ass'y to the front side.
2. Push the Locker R to remove the Cassette Side R.
3. Remove the Cassette Side L.

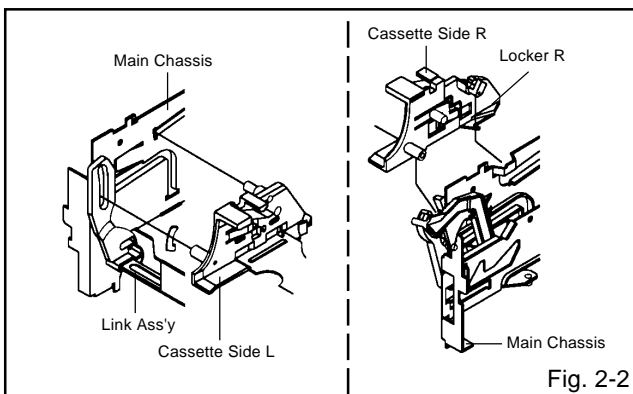

Fig. 2-2

2-3: CASSETTE SIDE L/R (Refer to Fig. 2-3-A)

1. Remove the Locker Spring.
2. Unlock the 4 supports ① and then remove the Cassette Side L/R.
3. Unlock the support ② and then remove the Locker R.

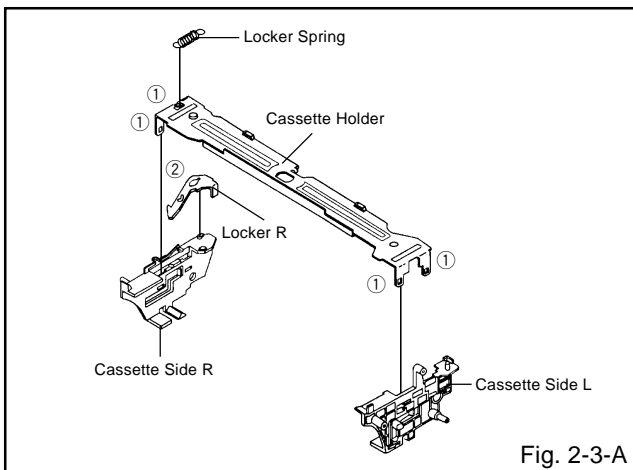

Fig. 2-3-A

NOTE

1. In case of the Locker R installation, check if the two positions of Fig.2-3-B are correctly locked.
2. When you install the Cassette Side R, be sure to move the Locker R after installing.

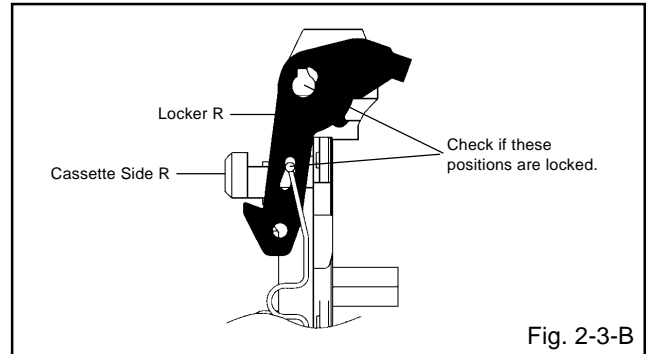

Fig. 2-3-B

2-4: LINK UNIT (Refer to Fig. 2-4)

1. Set the Link Unit to the Eject position.
2. Unlock the support ①.
3. Remove the (A) side of the Link Unit first, then remove the (B) side.

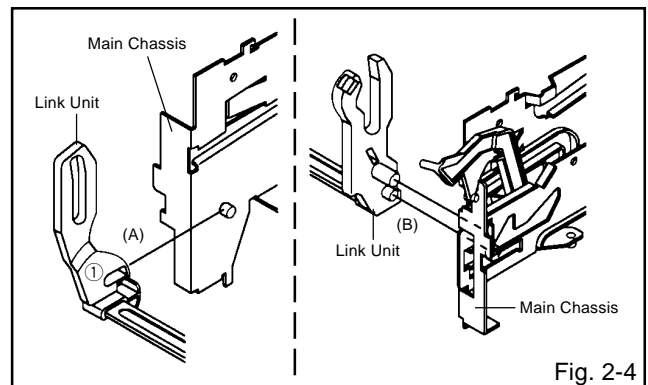

Fig. 2-4

2-5: LINK LEVER/FLAP LEVER (Refer to Fig. 2-5)

1. Remove the Link Lever.
2. Remove the Flap Lever.

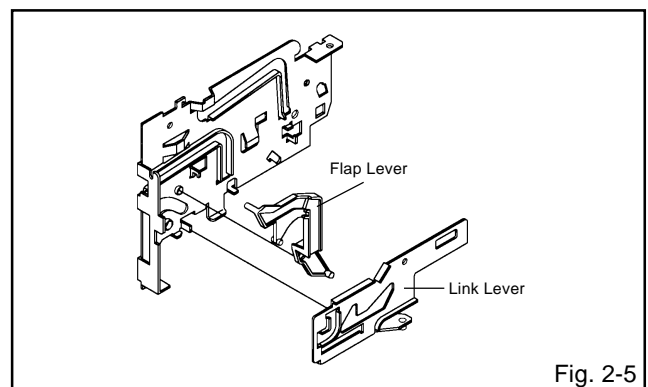
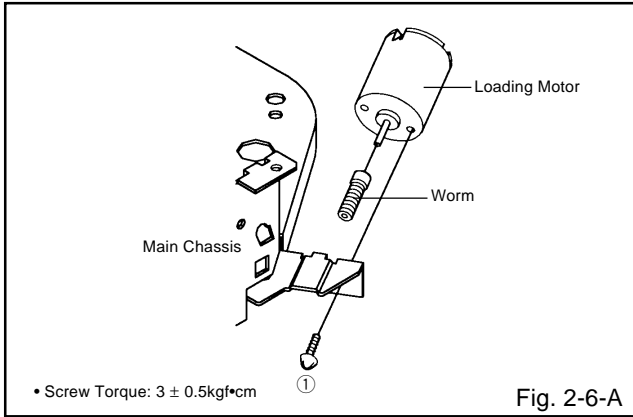

Fig. 2-5

DISASSEMBLY INSTRUCTIONS

2-6: LOADING MOTOR/WORM (Refer to Fig. 2-6-A)

1. Remove the screw ①.
2. Remove the Loading Motor.
3. Remove the Worm.



NOTE

1. In case of the Worm installation, check if the value of the Fig. 2-6-B is correct.

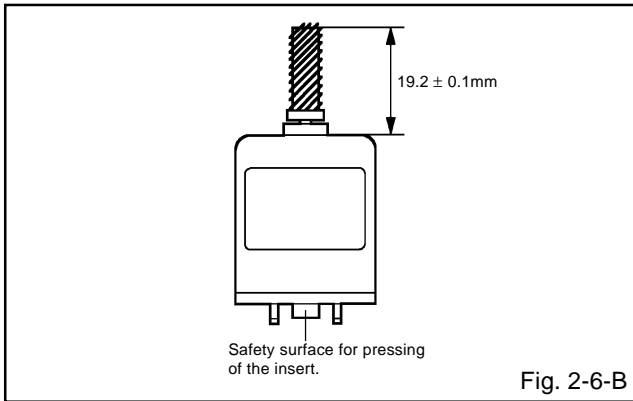

2-7: TENSION ASS'Y (Refer to Fig. 2-7-B)

1. Turn the Pinch Roller Cam clockwise so that the Tension Holder hook is set to the position of Fig. 2-7-A to move the Tension Arm Ass'y.
2. Remove the Tension Spring.
3. Unlock the 2 supports ① and remove the Tension Band.
4. Unlock the support ② and remove the Tension Arm Ass'y.
5. Unlock the support ③ and remove the Tension Connect.
6. Float the hook ④ and turn it clockwise then remove the Tension Holder.

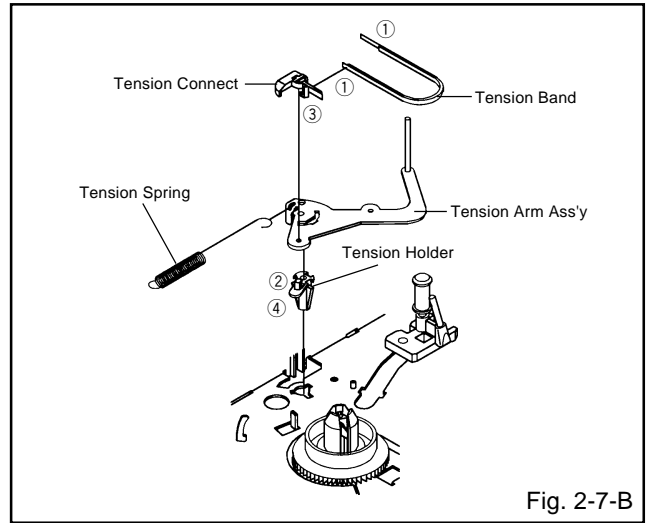
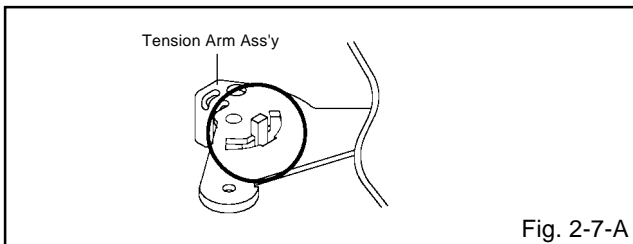

NOTE

1. In case of the Tension Band installation, note the direction of the installation. (Refer to Fig. 2-7-C)
2. In case of the Tension Band installation, install correctly as Fig. 2-7-D.
3. In case of the Tension Connect installation, install as the circled section of Fig. 2-7-E.

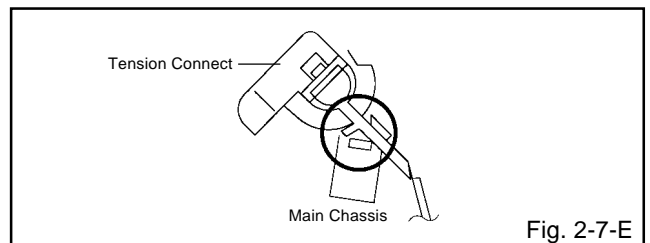
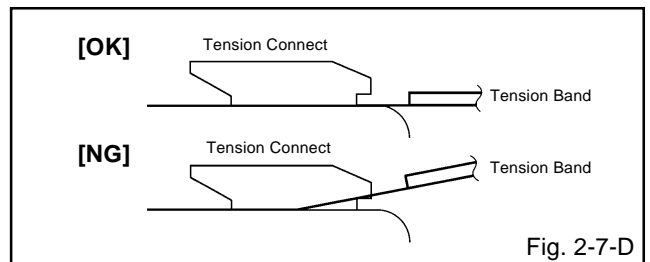
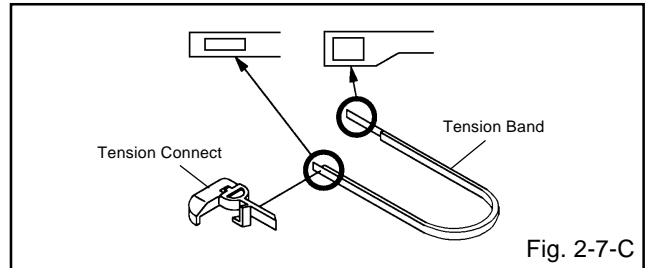

DISASSEMBLY INSTRUCTIONS

2-8: T BRAKE ARM/T BRAKE BAND (Refer to Fig. 2-8-A)

1. Remove the T Brake Spring.
2. Turn the T Brake Arm clockwise and bend the hook section to remove it.
3. Unlock the 2 supports ① and remove the T Brake Band.

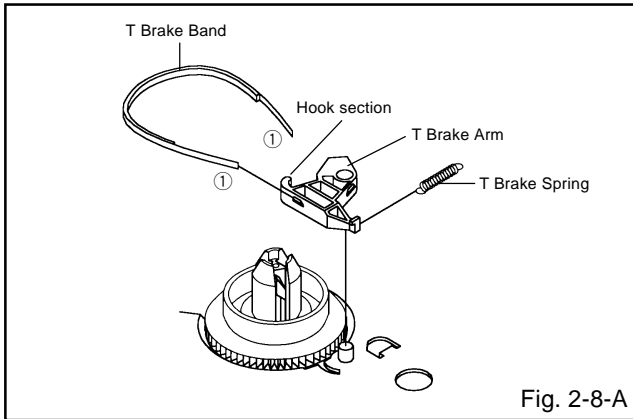

Fig. 2-8-A

NOTE

1. In case of the T Brake Band installation, install correctly as Fig. 2-8-B.

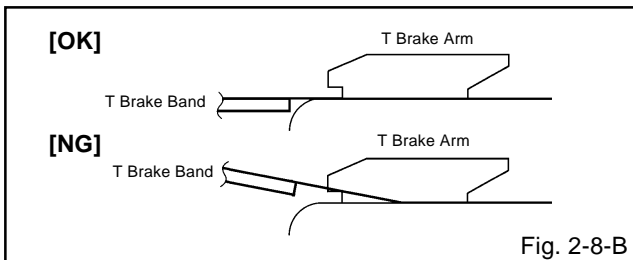

Fig. 2-8-B

2-9: S REEL/T REEL/IDLER ARM ASS'Y/IDLER GEAR (Refer to Fig. 2-9-A)

1. Remove the S Reel and T Reel.
2. Remove the 2 Polyslider Washers ①.
3. Remove the Idler Arm Ass'y and Idler Gear.

NOTE

1. Take care not to damage the gears of the S Reel and T Reel.
2. The Polyslider Washer may be remained on the back of the reel.
3. Take care not to damage the shaft.
4. Do not touch the section "A" of S Reel and T Reel. (Use gloves.) (Refer to Fig. 2-9-A) Do not adhere the stains on it.
5. When you install the reel, clean the shaft and grease it (MG-33). (If you do not grease, noise may be heard in FF/REW mode.)
6. After installing the reel, adjust the height of the reel. (Refer to MECHANICAL ADJUSTMENT)

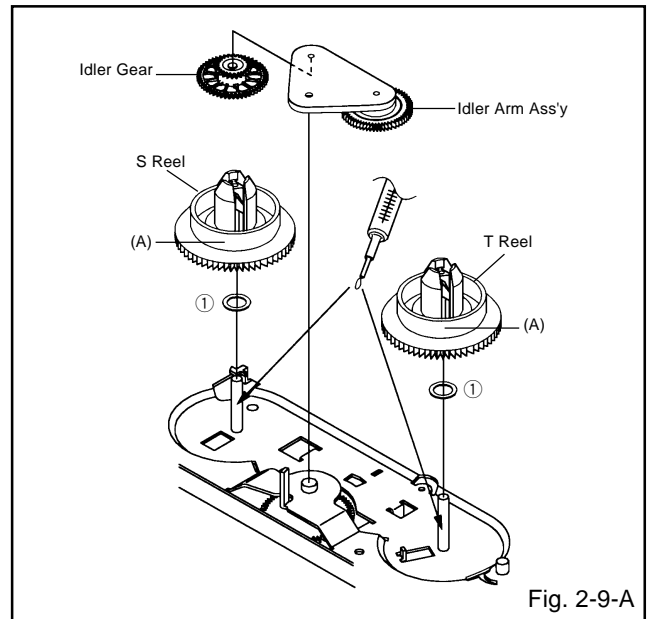

Fig. 2-9-A

NOTE

1. In case of the S Reel and T Reel installation, check if the correct parts are installed. (Refer to Fig. 2-9-B)
2. In case of the Idler Arm Ass'y installation, install correctly as Fig. 2-9-C.

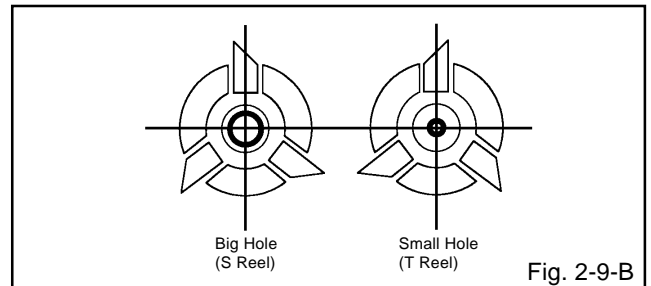

Fig. 2-9-B

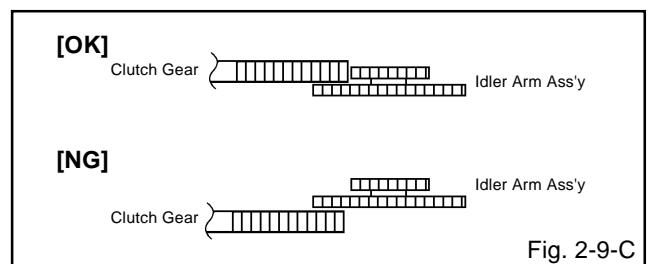
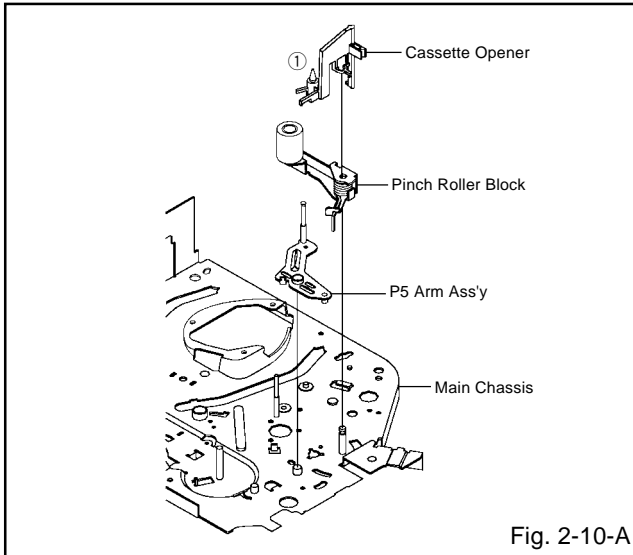

Fig. 2-9-C

DISASSEMBLY INSTRUCTIONS

2-10: CASSETTE OPENER/PINCH ROLLER BLOCK/ P5 ARM ASS'Y (Refer to Fig. 2-10-A)

1. Unlock the support ① and remove the Cassette Opener.
2. Remove the Pinch Roller Block and P5 Arm Ass'y.



NOTE

1. Do not touch the Pinch Roller. (Use gloves.)
2. In case of the Pinch Roller Block and the Pinch Roller Cam installation, install correctly as Fig. 2-10-B.

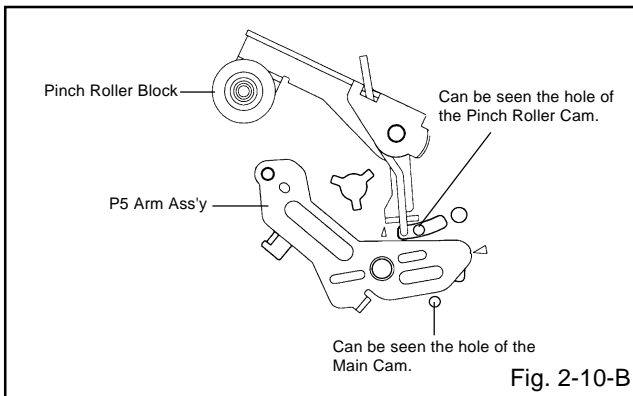

2-11: A/C HEAD (Refer to Fig. 2-11-A)

1. Remove the screw ①.
2. Remove the A/C Head Base.
3. Remove the 3 screws ②.
4. Remove the A/C Head and A/C Head Spring.

NOTE

1. Do not touch the A/C Head. (Use gloves.)
2. When you install the A/C Head Spring, install as shown in Fig. 2-11-B.
3. When you install the A/C Head, tighten the screw (1) first, then tighten the screw (2), finally tighten the screw (3).

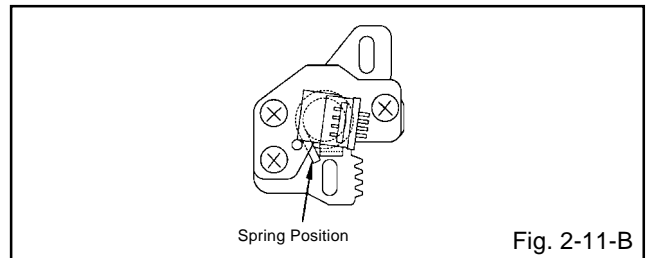
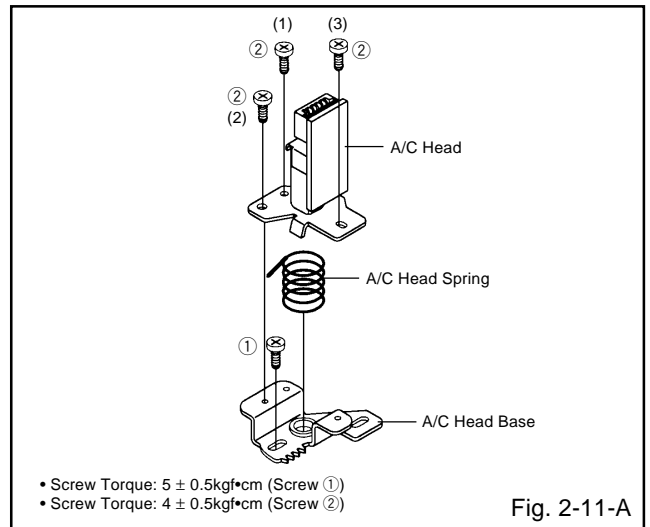

2-12: FE HEAD (RECORDER ONLY) (Refer to Fig. 2-12)

1. Remove the screw ①.
2. Remove the FE Head.

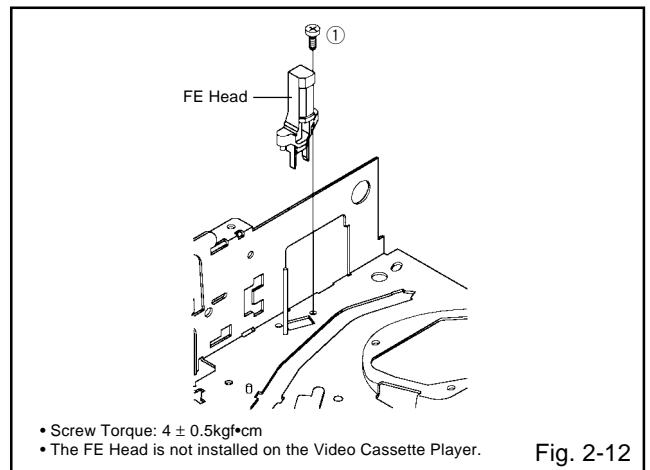

DISASSEMBLY INSTRUCTIONS

2-13: AHC ASS'Y/CYLINDER UNIT ASS'Y (Refer to Fig. 2-13)

1. Unlock the support ① and remove the AHC Ass'y.
2. Disconnect the following connector:
(CD2001)
3. Remove the 3 screws ②.
4. Remove the Cylinder Unit Ass'y.

NOTE

1. When you install the Cylinder Unit Ass'y, tighten the screws from (1) to (3) in order while pulling the Ass'y toward the left front direction.

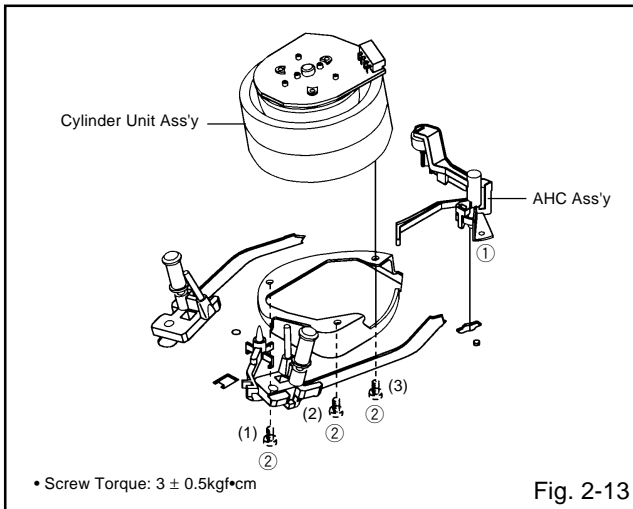

2-14: CAPSTAN DD UNIT (Refer to Fig. 2-14)

1. Remove the Capstan Belt.
2. Remove the 3 screws ①.
3. Remove the Capstan DD Unit.

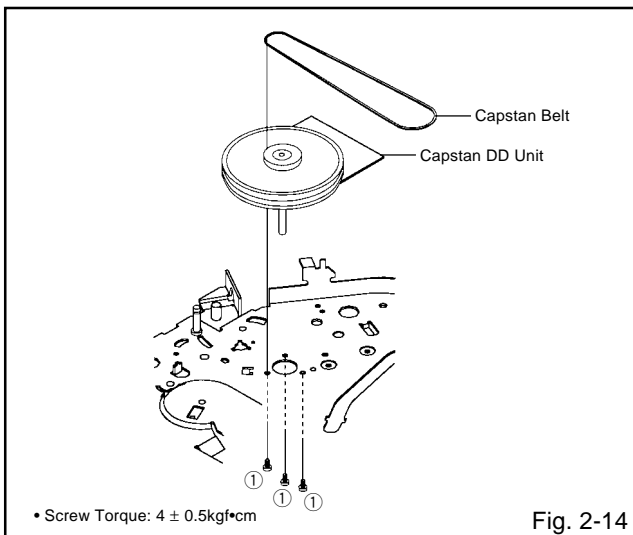

2-15: MAIN CAM/PINCH ROLLER CAM/JOINT GEAR (Refer to Fig. 2-15-A)

1. Remove the E-Ring ①, then remove the Main Cam.
2. Remove the E-Ring ②, then remove the Pinch Roller Cam and Joint Gear.

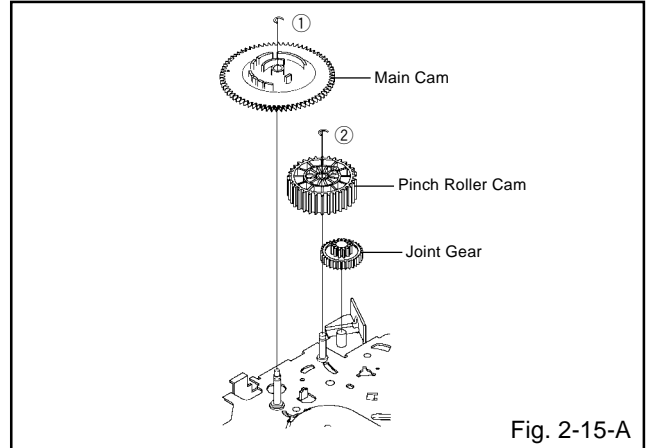

NOTE

1. In case of the Pinch Roller Cam and Main Cam installation, install them as the circled section of Fig. 2-15-B so that the each markers are met. (Refer to Fig. 2-15-B)

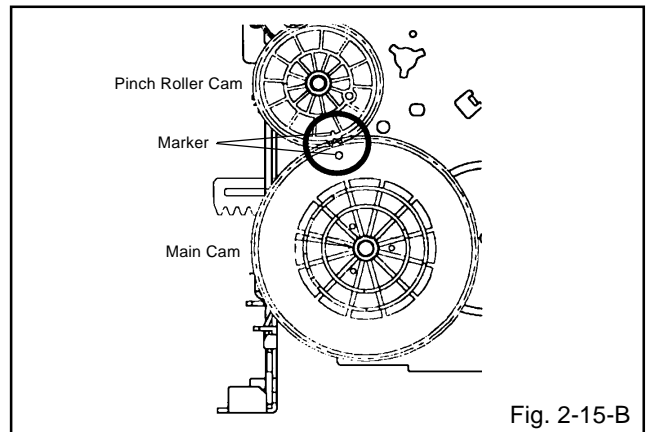

2-16: LOADING GEAR S/T ASS'Y (Refer to Fig. 2-16-A)

1. Remove the E-Ring ① and remove the Main Loading Gear.
2. Remove the Main Rod, Tension Lever, Loading Arm S Ass'y and Loading Arm T Ass'y.

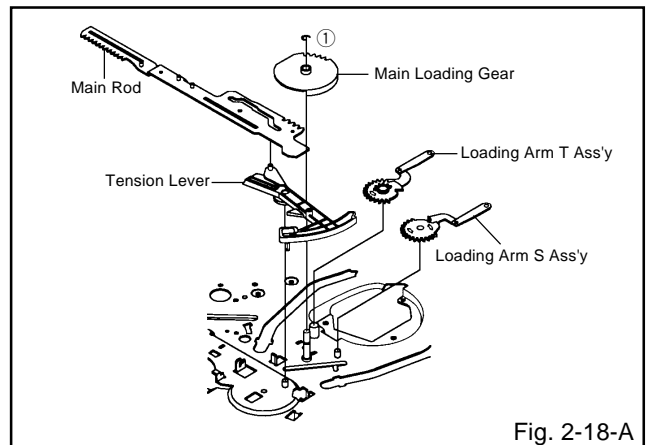

DISASSEMBLY INSTRUCTIONS

NOTE

1. When you install the Loading Arm S Ass'y, Loading Arm T Ass'y and Main Loading Gear, align each marker. (Refer to Fig. 2-16-B)

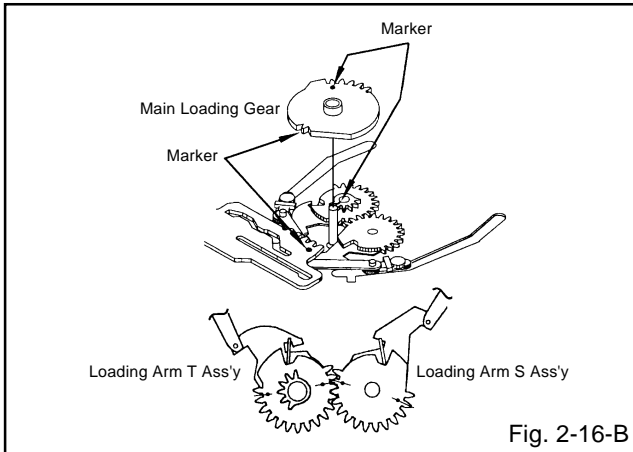

2-17: CLUTCH ASS'Y/RING SPRING/CLUTCH LEVER/CLUTCH GEAR (Refer to Fig. 2-17-A)

1. Remove the Polyslider Washer ①.
2. Remove the Clutch Ass'y and Ring Spring.
3. Remove the Clutch Lever.
4. Remove the Coupling Gear, Coupling Spring and Clutch Gear.

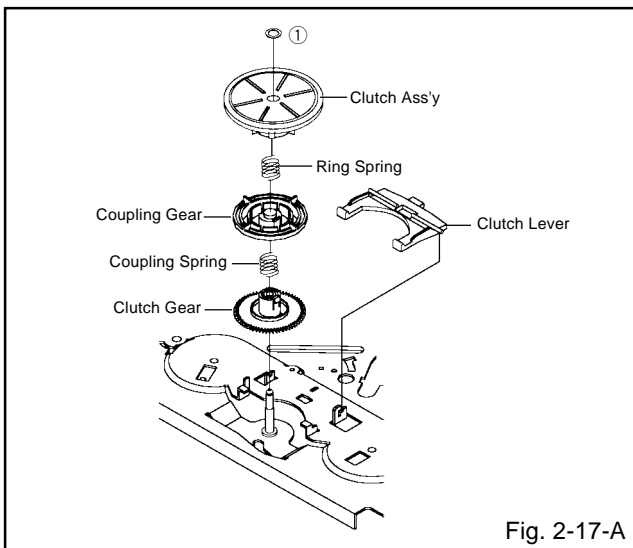

NOTE

1. In case of the Clutch Ass'y installation, install it with inserting the spring of the Clutch Ass'y into the dent of the Coupling Gear. (Refer to Fig. 2-17-B)

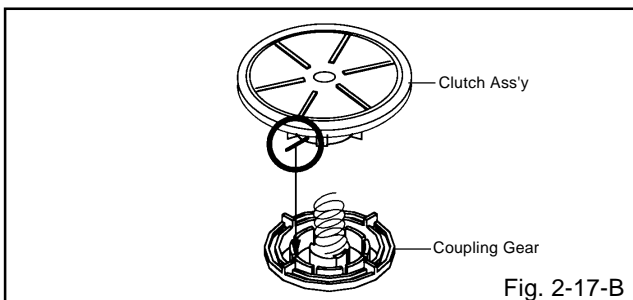

2-18: CASSETTE GUIDE POST/INCLINED BASE S/T UNIT/P4 CAP (Refer to Fig. 2-18-A)

1. Remove the P4 Cap.
2. Unlock the support ① and remove the Cassette Guide Post.
3. Remove the Inclined Base S Unit and Inclined Base T Unit.

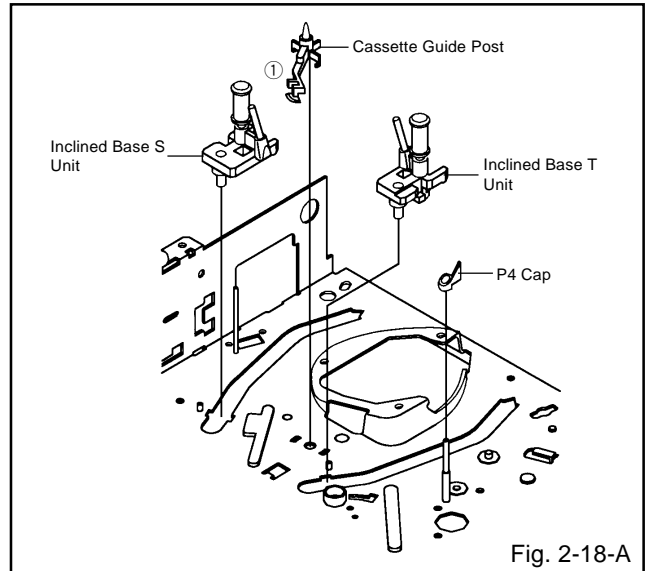

NOTE

1. Do not touch the roller of Guide Roller.
2. In case of the P4 Cap installation, install it with parallel for "A" and "B" of Fig. 2-18-B.
3. In case of the Cassette Guide Post installation, install correctly as the circled section of Fig. 2-18-C.

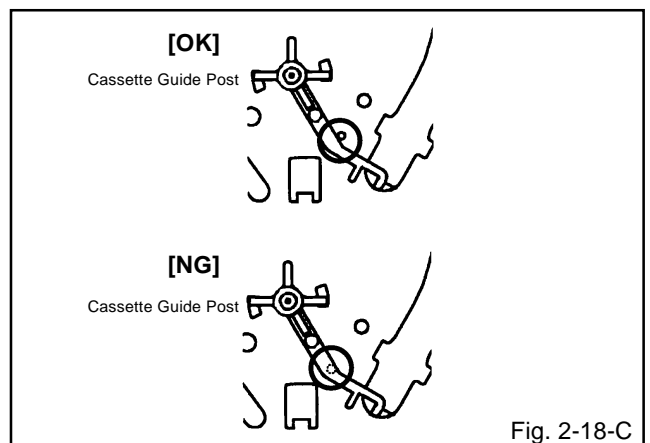
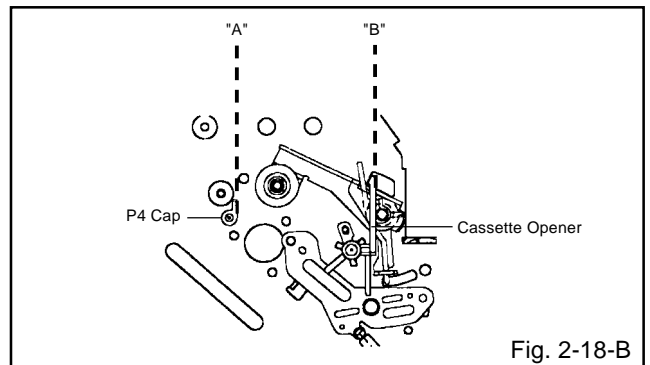

DISASSEMBLY INSTRUCTIONS

3. REMOVAL AND INSTALLATION OF FLAT PACKAGE IC

REMOVAL

1. Put the Masking Tape (cotton tape) around the Flat Package IC to protect other parts from any damage. (Refer to Fig. 3-1.)

NOTE

Masking is carried out on all the parts located within 10 mm distance from IC leads.

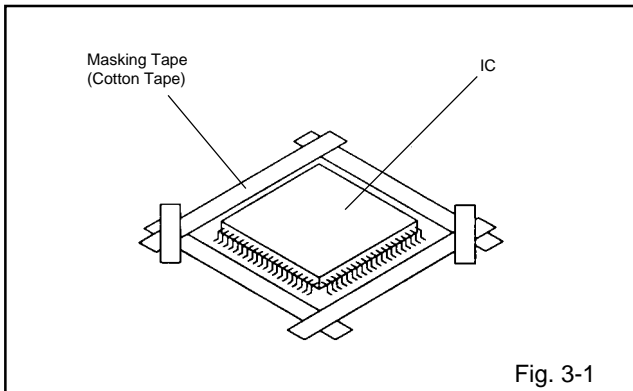

2. Heat the IC leads using a blower type IC desoldering machine. (Refer to Fig. 3-2.)

NOTE

Do not add the rotating and the back and forth directions force on the IC, until IC can move back and forth easily after desoldering the IC leads completely.

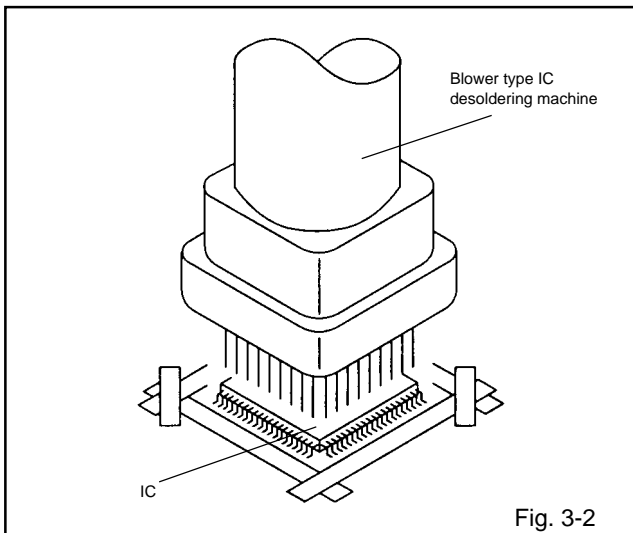

3. When IC starts moving back and forth easily after desoldering completely, pickup the corner of the IC using a tweezers and remove the IC by moving with the IC desoldering machine. (Refer to Fig. 3-3.)

NOTE

Some ICs on the PCB are affixed with glue, so be careful not to break or damage the foil of each IC leads or solder lands under the IC when removing it.

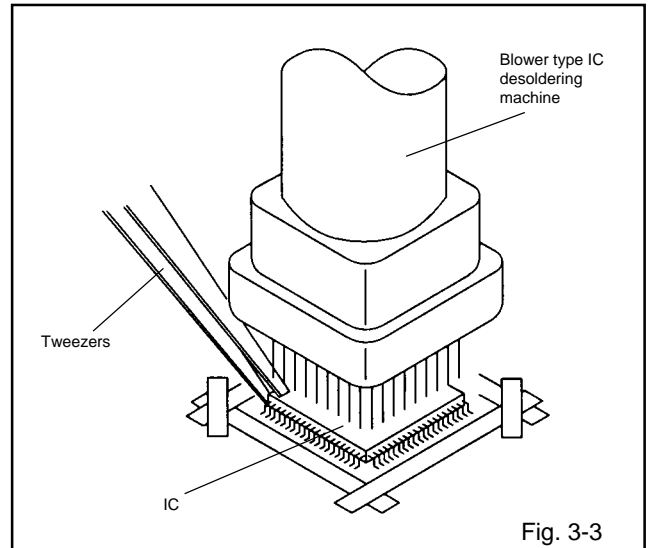

4. Peel off the Masking Tape.
5. Absorb the solder left on the pattern using the Braided Shield Wire. (Refer to Fig. 3-4.)

NOTE

Do not move the Braided Shield Wire in the vertical direction towards the IC pattern.

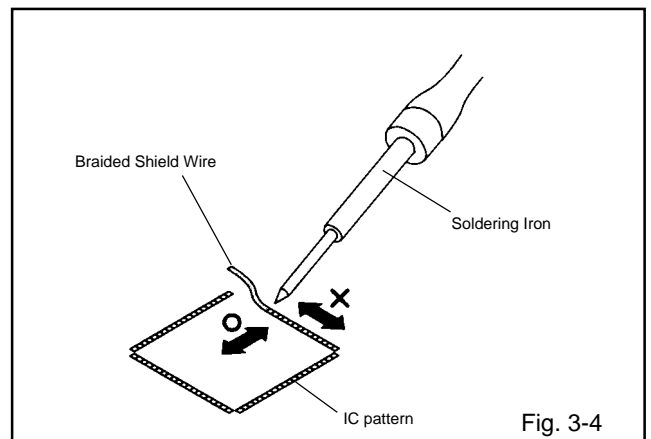

DISASSEMBLY INSTRUCTIONS

INSTALLATION

1. Take care of the polarity of new IC and then install the new IC fitting on the printed circuit pattern. Then solder each lead on the diagonal positions of IC temporarily. (Refer to Fig. 3-5.)

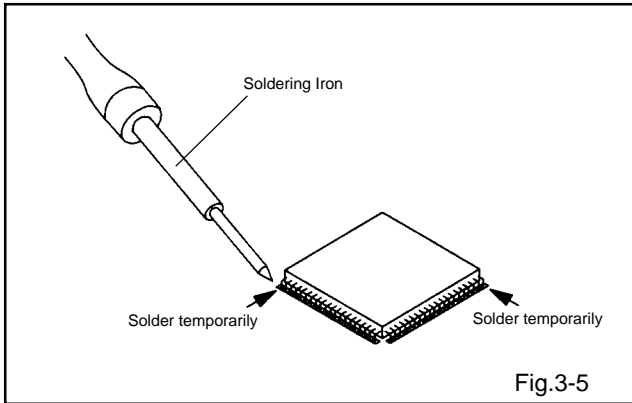

2. Supply the solder from the upper position of IC leads sliding to the lower position of the IC leads. (Refer to Fig. 3-6.)

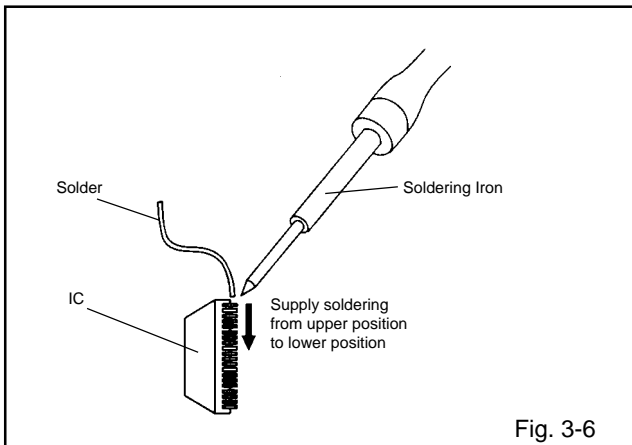

3. Absorb the solder left on the lead using the Braided Shield Wire. (Refer to Fig. 3-7.)

NOTE

Do not absorb the solder to excess.

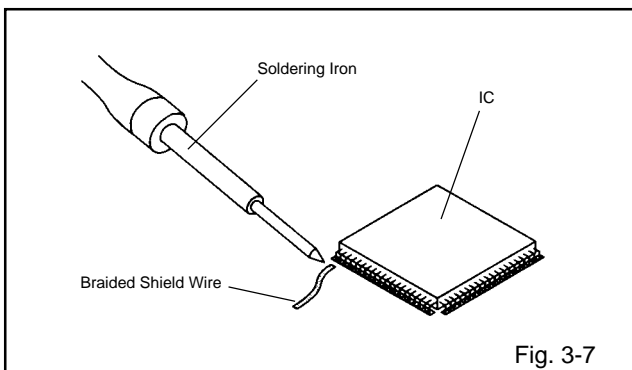

4. When bridge-soldering between terminals and/or the soldering amount are not enough, resolder using a Thin-tip Soldering Iron. (Refer to Fig. 3-8.)

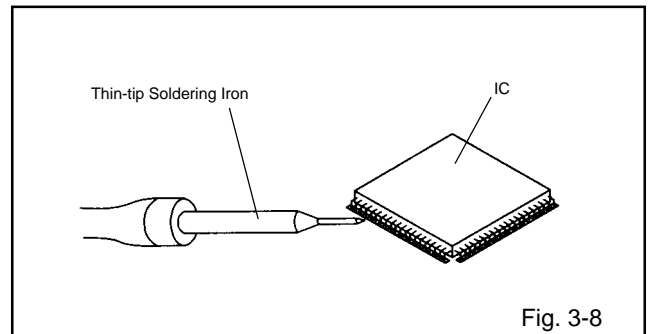

5. Finally, confirm the soldering status on four sides of the IC using a magnifying glass. Confirm that no abnormality is found on the soldering position and installation position of the parts around the IC. If some abnormality is found, correct by resoldering.

NOTE

When the IC leads are bent during soldering and/or repairing, do not repair the bending of leads. If the bending of leads are repaired, the pattern may be damaged. So, be always sure to replace the IC in this case.

KEY TO ABBREVIATIONS

A	A/C	: Audio/Control	H.SW	: Head Switch	
	ACC	: Automatic Color Control	Hz	: Hertz	
	AE	: Audio Erase	I	IC	: Integrated Circuit
	AFC	: Automatic Frequency Control		IF	: Intermediate Frequency
	AFT	: Automatic Fine Tuning		IND	: Indicator
	AFT DET	: Automatic Fine Tuning Detect		INV	: Inverter
	AGC	: Automatic Gain Control	K	KIL	: Killer
	AMP	: Amplifier	L	L	: Left
	ANT	: Antenna		LED	: Light Emitting Diode
	A.PB	: Audio Playback		LIMIT AMP	: Limiter Amplifier
	APC	: Automatic Phase Control		LM, LDM	: Loading Motor
	ASS'Y	: Assembly		LP	: Long Play
	AT	: All Time		L.P.F	: Low Pass Filter
	AUTO	: Automatic		LUMI.	: Luminance
	A/V	: Audio/Video	M	M	: Motor
B	BGP	: Burst Gate Pulse		MAX	: Maximum
	BOT	: Beginning of Tape		MINI	: Minimum
	BPF	: Bandpass Filter		MIX	: Mixer, mixing
	BRAKE SOL	: Brake Solenoid		MM	: Monostable Multivibrator
	BUFF	: Buffer		MOD	: Modulator, Modulation
	B/W	: Black and White		MPX	: Multiplexer, Multiplex
C	C	: Capacitance, Collector		MS SW	: Mecha State Switch
	CASE	: Cassette	N	NC	: Non Connection
	CAP	: Capstan		NR	: Noise Reduction
	CARR	: Carrier	O	OSC	: Oscillator
	CH	: Channel		OPE	: Operation
	CLK	: Clock	P	PB	: Playback
	CLOCK (SY-SE)	: Clock (Syscon to Servo)		PB CTL	: Playback Control
	COMB	: Combination, Comb Filter		PB-C	: Playback-Chrominance
	CONV	: Converter		PB-Y	: Playback-Luminance
	CPM	: Capstan Motor		PCB	: Printed Circuit Board
	CTL	: Control		P. CON	: Power Control
	CYL	: Cylinder		PD	: Phase Detector
	CYL-M	: Cylinder-Motor		PG	: Pulse Generator
	CYL SENS	: Cylinder-Sensor		P-P	: Peak-to Peak
D	DATA (SY-CE)	: Data (Syscon to Servo)	R	R	: Right
	dB	: Decibel		REC	: Recording
	DC	: Direct Current		REC-C	: Recording-Chrominance
	DD Unit	: Direct Drive Motor Unit		REC-Y	: Recording-Luminance
	DEMODO	: Demodulator		REEL BRK	: Reel Brake
	DET	: Detector		REEL S	: Reel Sensor
	DEV	: Deviation		REF	: Reference
E	E	: Emitter		REG	: Regulated, Regulator
	EF	: Emitter Follower		REW	: Rewind
	EMPH	: Emphasis		REV, RVS	: Reverse
	ENC	: Encoder		RF	: Radio Frequency
	ENV	: Envelope		RMC	: Remote Control
	EOT	: End of Tape		RY	: Relay
	EQ	: Equalizer	S	S. CLK	: Serial Clock
	EXT	: External		S. COM	: Sensor Common
F	F	: Fuse		S. DATA	: Serial Data
	FBC	: Feed Back Clamp		SEG	: Segment
	FE	: Full Erase		SEL	: Select, Selector
	FF	: Fast Forward, Flipflop		SENS	: Sensor
	FG	: Frequency Generator		SER	: Search Mode
	FL SW	: Front Loading Switch		SI	: Serial Input
	FM	: Frequency Modulation		SIF	: Sound Intermediate Frequency
	FSC	: Frequency Sub Carrier		SO	: Serial Output
	FWD	: Forward		SOL	: Solenoid
G	GEN	: Generator		SP	: Standard Play
	GND	: Ground		STB	: Serial Strobe
H	H.P.F	: High Pass Filter		SW	: Switch

KEY TO ABBREVIATIONS

S	SYNC	:	Synchronization
	SYNC SEP	:	Sync Separator, Separation
T	TR	:	Transistor
	TRAC	:	Tracking
	TRICK PB	:	Trick Playback
	TP	:	Test Point
U	UNREG	:	Unregulated
V	V	:	Volt
	VCO	:	Voltage Controlled Oscillator
	VIF	:	Video Intermediate Frequency
	VP	:	Vertical Pulse, Voltage Display
	V.PB	:	Video Playback
	VR	:	Variable Resistor
	V.REC	:	Video Recording
	VSF	:	Visual Search Fast Forward
	VSR	:	Visual Search Rewind
	VSS	:	Voltage Super Source
	V-SYNC	:	Vertical-Synchronization
	VT	:	Voltage Tuning
X	X'TAL	:	Crystal
Y	Y/C	:	Luminance/Chrominance

SERVICE MODE LIST

This unit provided with the following SERVICE MODES so you can repair, examine and adjust easily.

Method	Operations
Press the ATR button on the remote control for more than 2 seconds during PLAY.	Adjusting of the Tracking to the center position. Refer to the "MECHANICAL ADJUSTMENT" (GUIDE ROLLER) and "ELECTRICAL ADJUSTMENT" (PG SHIFTER).
Make the short circuit between the test point of SERVICE and the GND.	The EOT/BOT/Reel sensor do not work at this moment. Refer to the "PREPARATION FOR SERVICING"

PREVENTIVE CHECKS AND SERVICE INTERVALS

The following standard table depends on environmental conditions and usage. Unless maintenance is properly carried out, the following service intervals may be quite shortened as harmful effects may be had on other parts. Also, long term storage or misuse may cause transformation and aging of rubber parts.

Time Parts Name	500 hours	1,000 hours	1,500 hours	2,000 hours	3,000 hours	Notes
Audio Control Head	■	■	■	■	■	Clean those parts in contact with the tape.
Full Erase Head (Recorder only)	■	■	■	■	■	
Capstan Belt			■	■	●	Clean the rubber, and parts which the rubber touches.
Pinch Roller	■	■	■	■	■ ●	
Capstan DD Unit					●	
Loading Motor					●	
Tension Band					●	
Capstan Shaft	■	■	■	■	■	Replace when rolling becomes abnormal.
Tape Running Guide Post	■	■	■	■	■	
Cylinder Unit	■	■	■	■	●	Clean the Head

■ : Clean
● : Replace

CLEANING

NOTE

After cleaning the heads with isopropyl alcohol, do not run a tape until the heads dry completely. If the heads are not completely dry and alcohol gets on the tape, damage may occur.

1. AUDIO CONTROL HEAD

Clean the Audio Control Head with the cotton stick soaked by alcohol. Clean the full erase head in the same manner. (Refer to the figure below.)

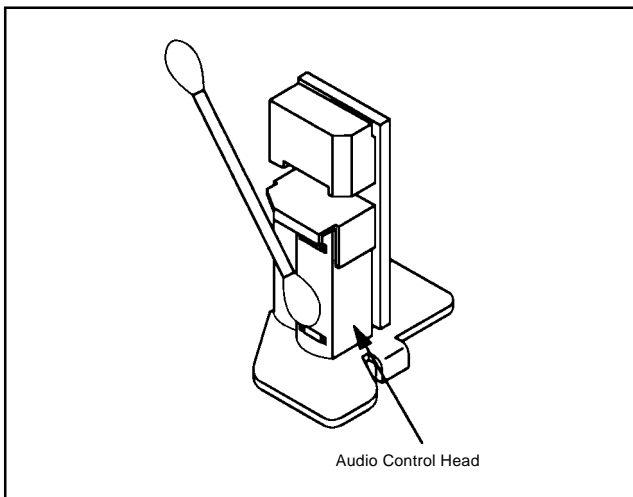

2. TAPE RUNNING SYSTEM

When cleaning the tape transport system, use the gauze moistened with isopropyl alcohol.

3. CYLINDER

Wrap a piece of chamois around your finger. Dip it in isopropyl alcohol. Hold it to the cylinder head softly. Turn the cylinder head counterclockwise to clean it (in the direction of the arrow). (Refer to the figure below.)

NOTE

Do not exert force against the cylinder head. Do not move the chamois upward or downward on the head. Use the chamois one by one.

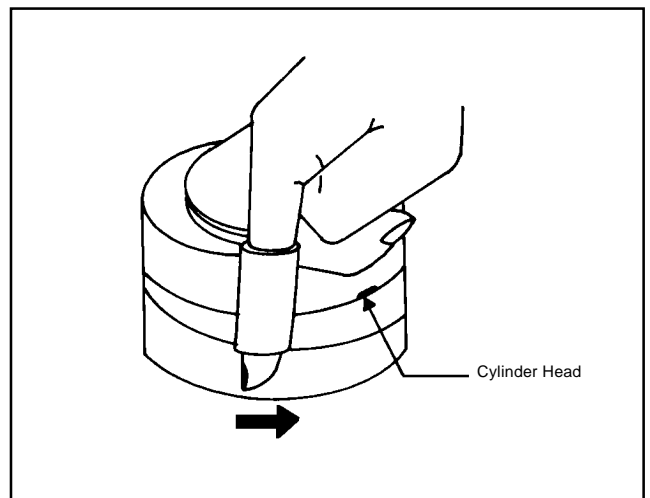

SERVICING FIXTURES AND TOOLS

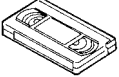
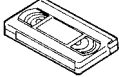
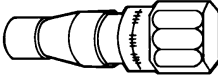
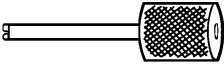
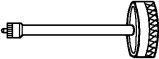
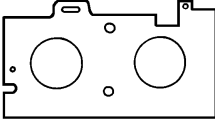
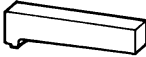
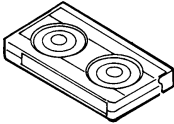
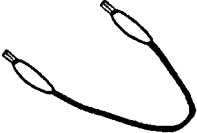
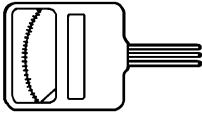
<p>(For 2 heads model) VHS Alignment Tape JG001 (VN₂S-LI6³) JG001A (VN₂S-CO1³) JG001Q (VN₂S-LI6³H) JG001T (VN₂S-X6³)</p> 	<p>(For 4 heads model) VHS Alignment Tape JG001B (VN₁S-LI6³) JG001I (VN₁S-CO1³) JG001P (VN₁S-LI6³H) JG001S (VN₁S-X6³)</p> 	<p>JG002B Adapter JG002E Dial Torque Gauge (10~90gf•cm) JG002F (60~600gf•cm)</p> 	<p>JG005 Post Adjustment Screwdriver Part No. SV-TG0-030-000 (small)</p> 
<p>JG153 X Value Adjustment Screwdriver</p> 	<p>JG022 Master Plane</p> 	<p>JG024A Reel Disk Height Adjustment Jig</p> 	<p>JG100A Torque Tape (VHT-063)</p> 
<p>JG154 Cable</p> 	<p>Tentelometer</p> 		

Ref. No.	Part No.	Parts Name	Remarks
JG001	APJG001000	VHS Alignment Tape (For 2 heads model)	Monoscope, 6KHz
JG001A	APJG001A00	VHS Alignment Tape (For 2 heads model)	Color Bar, 1KHz
JG001Q	APJG001Q00	VHS Alignment Tape (For 2 heads model)	Hi-Fi Audio
JG001T	APJG001T00	VHS Alignment Tape (For 2 heads model)	X Value Adjustment
JG001B	APJG001B00	VHS Alignment Tape (For 4 heads model)	Monoscope, 6KHz
JG001I	APJG001I00	VHS Alignment Tape (For 4 heads model)	Color Bar, 1KHz
JG001P	APJG001P00	VHS Alignment Tape (For 4 heads model)	Hi-Fi Audio
JG001S	APJG001S00	VHS Alignment Tape (For 4 heads model)	X Value Adjustment
JG002B	APJG002B00	Adapter	VSR Torque, Brake Torque (S Reel/T Reel Ass'y)
JG002E	APJG002E00	Dial Torque Gauge (10~90gf•cm)	Brake Torque (T Reel Ass'y)
JG002F	APJG002F00	Dial Torque Gauge (60~600gf•cm)	VSR Torque, Brake Torque (S Reel)
JG005	APJG005000	Post Adjustment Screwdriver	Guide Roller Adjustment
JG153	APJG153000	X Value Adjustment Screwdriver	X Value Adjustment
JG022	APJG022000	Master Plane	Reel Disk Height Adjustment
JG024A	APJG024A00	Reel Disk Height Adjustment Jig	Reel Disk Height Adjustment
JG100A	APJG100A00	Torque Tape (VHT-063)	Playback Torque, Back Tension Torque During Playback
JG154	APJG154000	Cable	Used to connect the test point of SERVICE and GROUND

PREPARATION FOR SERVICING

- Short circuit between **TP1001** and **Ground** with the cable JG154.
(Refer to MAJOR COMPONENTS LOCATION GUIDE)
The EOT, BOT and Reel Sensor do not work at this moment.
At that time, the STOP/EJECT button is available to insert and eject the Cassette Tape.

MECHANICAL ADJUSTMENTS

1. CONFIRMATION AND ADJUSTMENT

Read the following NOTES before starting work.

- Place an object which weighs between 450g~500g on the Cassette Tape to keep it steady when you want to make the tape run without the Cassette Holder. (Do not place an object which weighs over 500g.)
- When you activate the deck without the Cassette Holder, short circuit between **TP1001** and **GND**. (Refer to **ELECTRICAL ADJUSTMENT PARTS LOCATION GUIDE**) In this condition the BOT/EOT/Reel Sensor will not function.

1-1: CONFIRMATION AND ADJUSTMENT OF REEL DISK HEIGHT

1. Turn on the power and set to the STOP mode.
2. Set the master plane (**JG022**) and reel disk height adjustment jig (**JG024A**) on the mechanism framework, taking care not to scratch the drum, as shown in **Fig. 1-1-A**.
3. While turning the reel and confirm the following points. Check if the surface "A" of reel disk is lower than the surface "B" of reel disk height adjustment jig (**JG024A**) and is higher than the surface "C". If it is not passed, place the height adjustment washers and adjust to 10(+2, -0)mm.
4. Adjust the other reel in the same way.

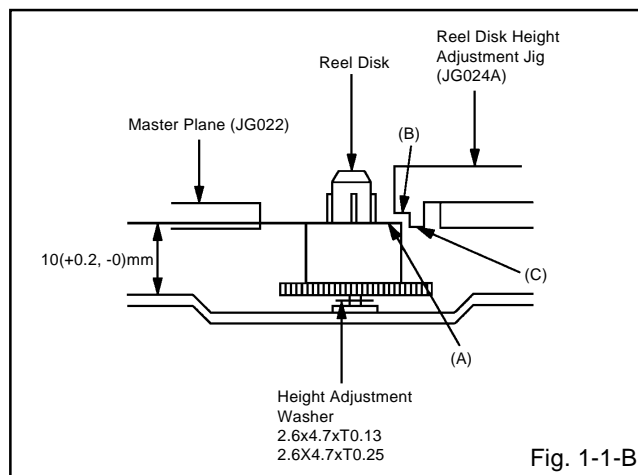
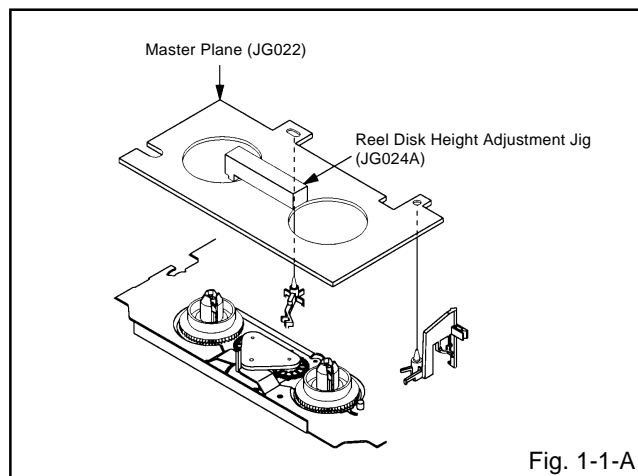

1-2: CONFIRMATION AND ADJUSTMENT OF TENSION POST POSITION

1. Set to the PLAY mode.
2. Adjust the adjusting parts for the Tension Arm position so that the Tension Arm top is within the standard line of Main Chassis.
3. While turning the S Reel clockwise, confirm that the edge of the Tension Arm is located in the position described above.

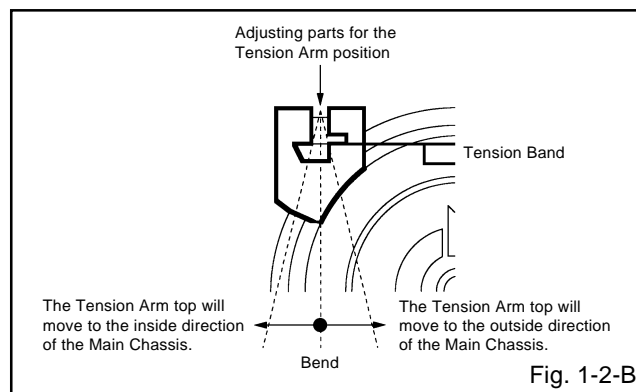
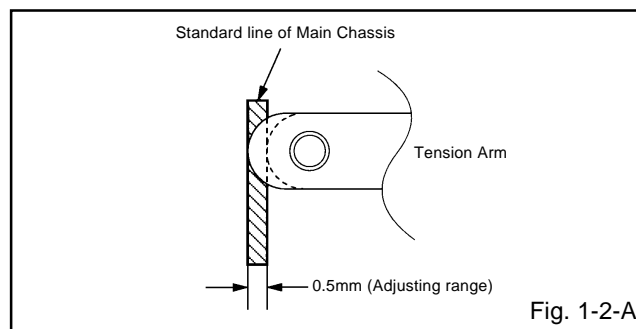

1-3: CONFIRMATION OF PLAYBACK TORQUE AND BACK TENSION TORQUE DURING PLAYBACK

1. Load a video tape (T-120) recorded in standard speed mode. Set the unit to the PLAY mode.
2. Install the tentelometer as shown in **Fig. 1-3**. Confirm that the meter indicates $20 \pm 2\text{gf}$ in the beginning of playback.

• USING A CASSETTE TYPE TORQUE TAPE (**JG100A**)

1. After confirmation and adjustment of Tension Post position (Refer to item 1-2), load the cassette type torque tape (**JG100A**) and set to the PLAY mode.
2. Confirm that the right meter of the torque tape indicates 50~90gf•cm during playback in SP mode.
3. Confirm that the left meter of the torque tape indicates 25~40gf•cm during playback in SP mode.

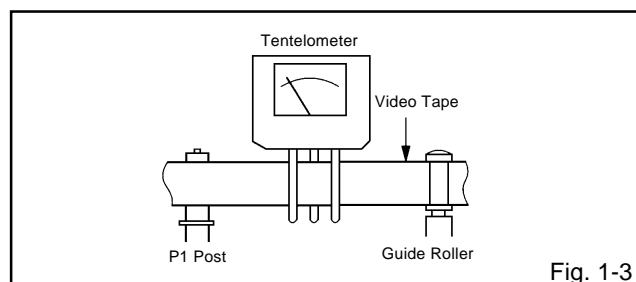

MECHANICAL ADJUSTMENTS

1-4: CONFIRMATION OF VSR TORQUE

1. Install the Torque Gauge (JG002F) and Adapter (JG002B) on the S Reel. Set to the Picture Search (Rewind) mode. (Refer to Fig.1-4-B)
2. Then, confirm that it indicates 120~180gf•cm.

NOTE

Install the Torque Gauge on the reel disk firmly. Press the REW button to turn the reel disk.

1-5: CONFIRMATION OF REEL BRAKE TORQUE

(S Reel Brake) (Refer to Fig.1-4-B)

1. Once set to the Fast Forward mode then set to the Stop mode. While, unplug the AC cord when the Pinch Roller Block is on the position of Fig. 1-4-A.
2. Move the Idler Ass'y from the S Reel.
3. Install the Torque Gauge (JG002F) and Adapter (JG002B) on the S Reel. Turn the Torque Gauge (JG002F) clockwise.
4. Then, confirm that it indicates 60~100gf•cm.

(T Reel Brake) (Refer to Fig. 1-4-B)

1. Once set to the Fast Forward mode then set to the Stop mode. While, unplug the AC cord when the Pinch Roller Block is on the position of Fig. 1-4-A.
2. Move the Idler Ass'y from the T Reel.
3. Install the Torque Gauge (JG002E) and Adapter (JG002B) on the T reel. Turn the Torque Gauge (JG002E) counterclockwise.
4. Then, confirm that it indicates 30~50gf•cm.

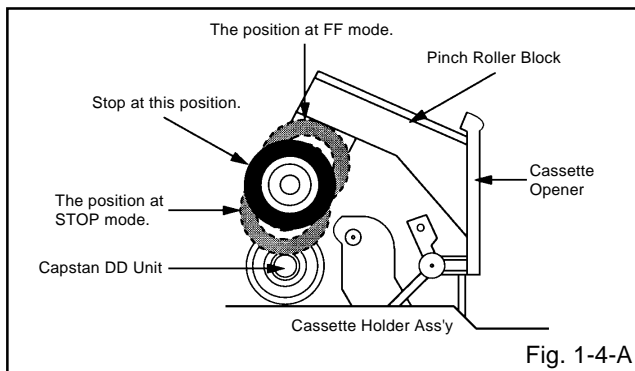

Fig. 1-4-A

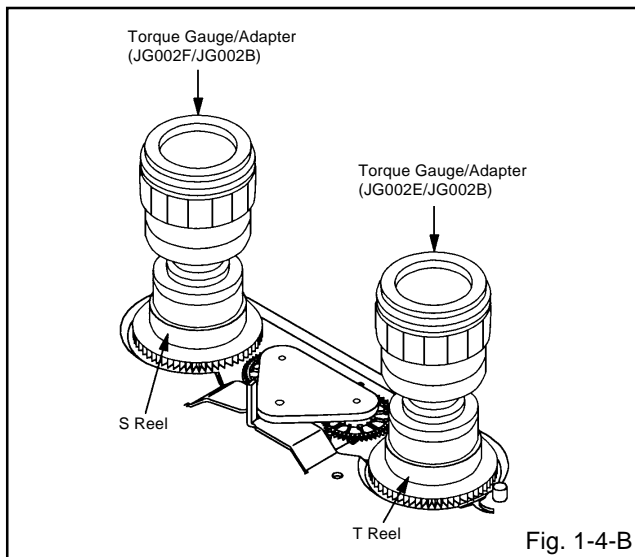

Fig. 1-4-B

NOTE

If the torque is out of the range, replace the following parts.

Check item	Replacement Part
1-4	Idler Ass'y/Clutch Ass'y
1-5	S Reel side: S Reel/Tension Band/Tension Connect/Tension Arm Ass'y T Reel side: T Reel/T Brake Band//T Brake Spring/T Brake Arm

2. CONFIRMATION AND ADJUSTMENT OF TAPE RUNNING MECHANISM

Tape Running Mechanism is adjusted precisely at the factory. Adjustment is not necessary as usual. When you replace the parts of the tape running mechanism because of long term usage or failure, the confirmation and adjustment are necessary.

2-1: GUIDE ROLLER

1. Playback the VHS Alignment Tape (JG001 or JG001B). (Refer to SERVICING FIXTURE AND TOOLS)
2. Connect CH-1 of the oscilloscope to TP4001 (Envelope) and CH-2 to TP1002 (SW Pulse).
3. Press and hold the Tracking-Auto button on the remote control more than 2 seconds to set tracking to center.
4. Trigger with SW Pulse and observe the envelope. (Refer to Fig. 2-1-A)
5. When observing the envelope, adjust the Adjusting Driver (JG005) slightly until the envelope will be flat. Even if you press the Tracking Button, adjust so that flatness is not moved so much.
6. Adjust so that the A : B ratio is better than 3 : 2 as shown in Fig. 2-1-B, even if you press the Tracking Button to move the envelope (The envelope waveform will begin to decrease when you press the Tracking Button).
7. Adjust the PG shifter during playback. (Refer to the ELECTRICAL ADJUSTMENTS)

NOTE

After adjustment, confirm and adjust A/C head. (Refer to item 2-2)

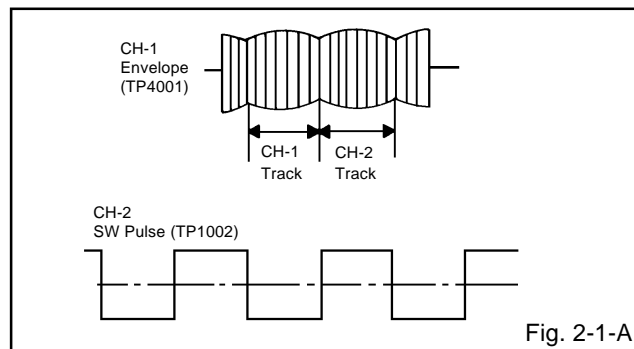

Fig. 2-1-A

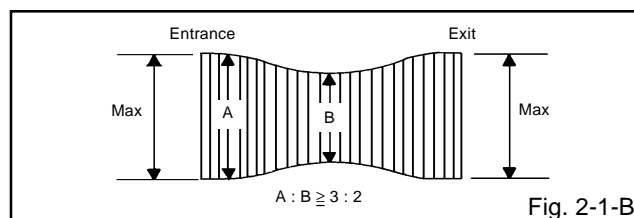

Fig. 2-1-B

MECHANICAL ADJUSTMENTS

2-2: CONFIRMATION AND ADJUSTMENT OF AUDIO/ CONTROL HEAD

When the Tape Running Mechanism does not work well, adjust the following items.

1. Playback the VHS Alignment Tape (**JG001** or **JG001B**) .
(Refer to **SERVICING FIXTURE AND TOOLS**)
2. Confirm that the reflected picture of stamp mark is appeared on the tape prior to P4 Post as shown in **Fig. 2-2-A**.
 - a) When the reflected picture is distorted, turn the screw ① clockwise until the distortion is disappeared.
 - b) When the reflected picture is not distorted, turn the screw ① counterclockwise until little distortion is appeared, then adjust the a).
3. Turn the screw ② to set the audio level to maximum.
4. Confirm that the bottom of the Audio/ Control Head and the bottom of the tape is shown in **Fig. 2-2-C**.
 - a) When the height is not correct, turn the screw ③ to adjust the height. Then, adjust the 1~3 again.

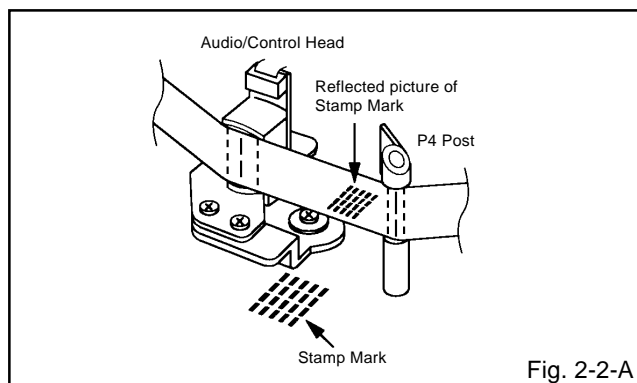

Fig. 2-2-A

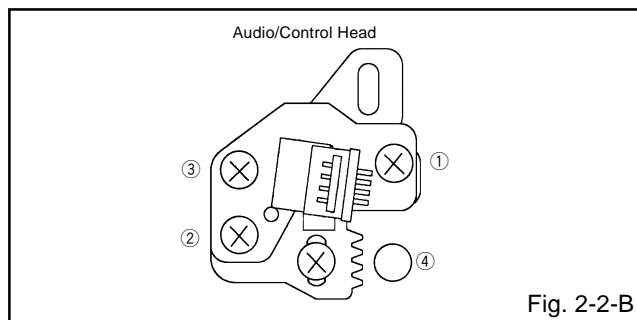

Fig. 2-2-B

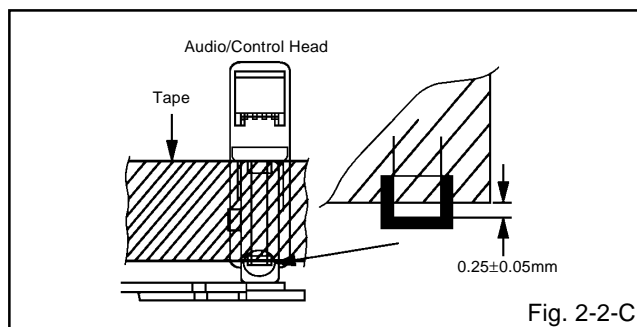

Fig. 2-2-C

2-3: TAPE RUNNING ADJUSTMENT (X VALUE ADJUSTMENT)

1. Confirm and adjust the height of the Reel Disk.
(Refer to **item 1-1**)
2. Confirm and adjust the position of the Tension Post.
(Refer to **item 1-2**)
3. Adjust the Guide Roller. (Refer to **item 2-1**)
4. Confirm and adjust the Audio/Control Head.
(Refer to **item 2-2**)
5. Connect CH-1 of the oscilloscope to **TP4001**, CH-2 to **TP1002** and CH-3 to **HOT side of Audio Out Jack**.
6. Playback the VHS Alignment Tape (**JG001S** or **JG001T**). (Refer to **SERVICING FIXTURE AND TOOLS**)
7. Press and hold the Tracking-Auto button on the remote control more than 2 seconds to set tracking to center.
8. Set the X Value adjustment driver (**JG153**) to the ④ of **Fig. 2-2-B**. Adjust X value so that the envelope waveform output becomes maximum. Check if the relation between Audio and Envelope waveform becomes (1) or (2) of **Fig. 2-3**.

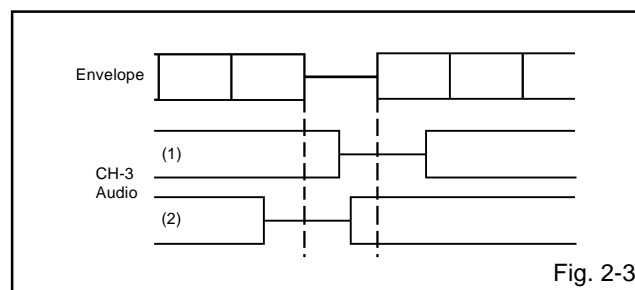

Fig. 2-3

2-4: CONFIRM HI-FI AUDIO (Hi-Fi model only)

1. Connect CH-1 of the oscilloscope to **TP1002** and CH-2 to the **Hi-Fi Audio Out Jack**.
2. Playback the VHS Alignment Tape (**JG001P** or **JG001Q**).
(Refer to **SERVICING FIXTURE AND TOOLS**)
3. Press and hold the Tracking-Auto button on the remote control more than 2 seconds to set tracking to center.
4. Press the Tracking Up button and count number of steps which the audio output is changed from Hi-Fi (10KHz) to MONO (6KHz).
5. Press and hold the Tracking-Auto button on the remote control more than 2 seconds to set tracking to center.
6. Press the Tracking Down button and count number of steps which the audio output is changed from Hi-Fi (10KHz) to MONO (6KHz).
7. If the difference are more than 3 steps, set the X Value adjustment driver (**JG153**) to ④ of **Fig. 2-2-B**. Change the X Value and adjust it so that the value becomes within 2 steps.

MECHANICAL ADJUSTMENTS

3. MECHANISM ADJUSTMENT PARTS LOCATION GUIDE

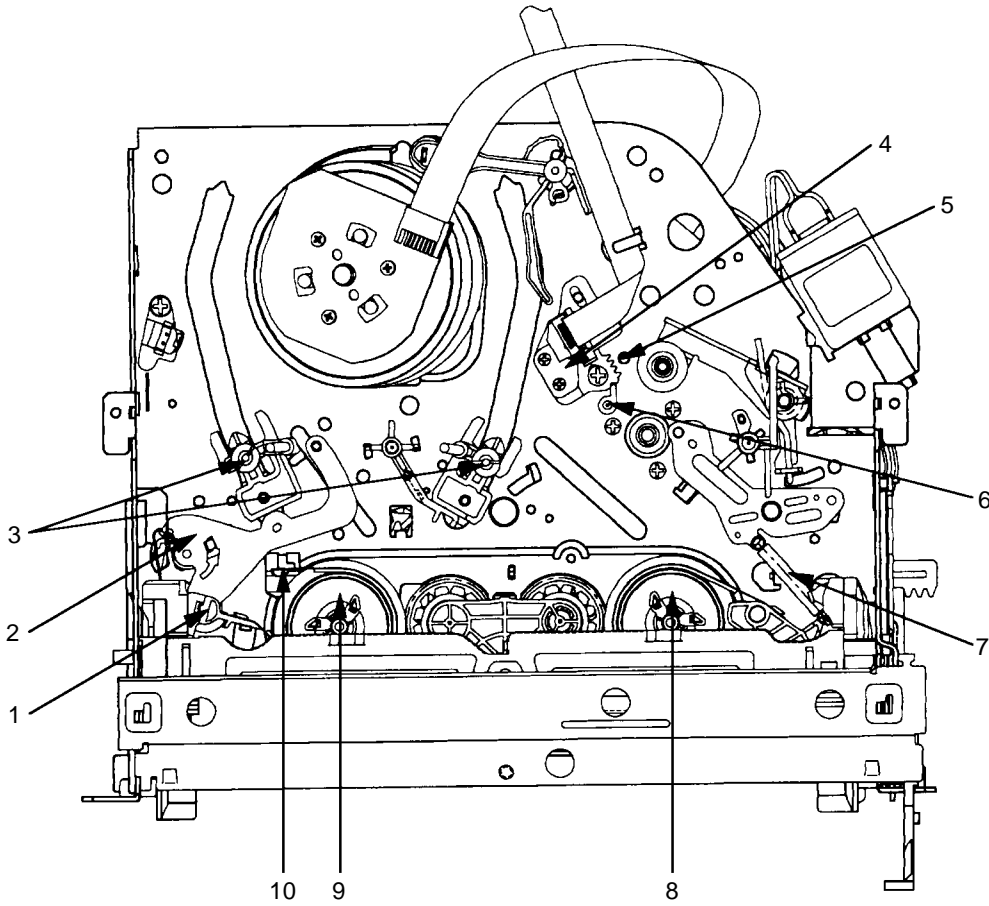

- | | |
|-----------------------------------|--|
| 1. Tension Connect | 6. P4 Post |
| 2. Tension Arm | 7. T Brake Spring |
| 3. Guide Roller | 8. T Reel |
| 4. Audio/Control Head | 9. S Reel |
| 5. X value adjustment driver hole | 10. Adjusting parts for the Tension Arm position |

ELECTRICAL ADJUSTMENTS

Read and perform this adjustment when repairing the circuits or replacing electrical parts or PCB assemblies.

1. BASIC ADJUSTMENT

CAUTION

When replacing IC's or transistors, use only specified silicon grease (**YG6260M**).
(To prevent the damage to IC's and transistors.)

1-1: PG SHIFTER

CONDITIONS

MODE-PLAYBACK
Input Signal-Alignment Tape (**JG001P**)

INSTRUCTIONS

1. Connect CH-1 on the oscilloscope to **TP1002** and CH-2 to **TP4201**.
2. Playback the alignment tape. (**JG001P**)
3. Press and hold the Tracking-Auto button on the remote control more than 2 seconds to set tracking to center.
4. Adjust the **VR1001** until the waveform of the oscilloscope measures $6.5 \pm 0.5(H)$ at both leading and trailing edges. (Refer to Fig. 1-1-A, B)

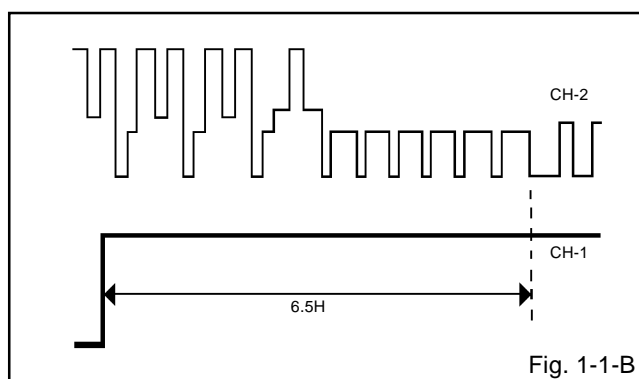
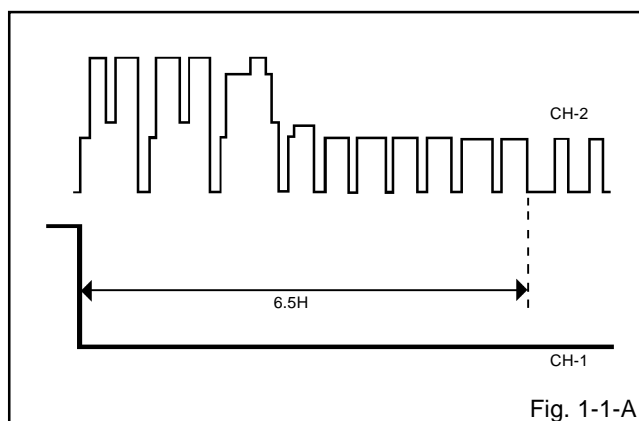

ELECTRICAL ADJUSTMENTS

2. ELECTRICAL ADJUSTMENT PARTS LOCATION GUIDE

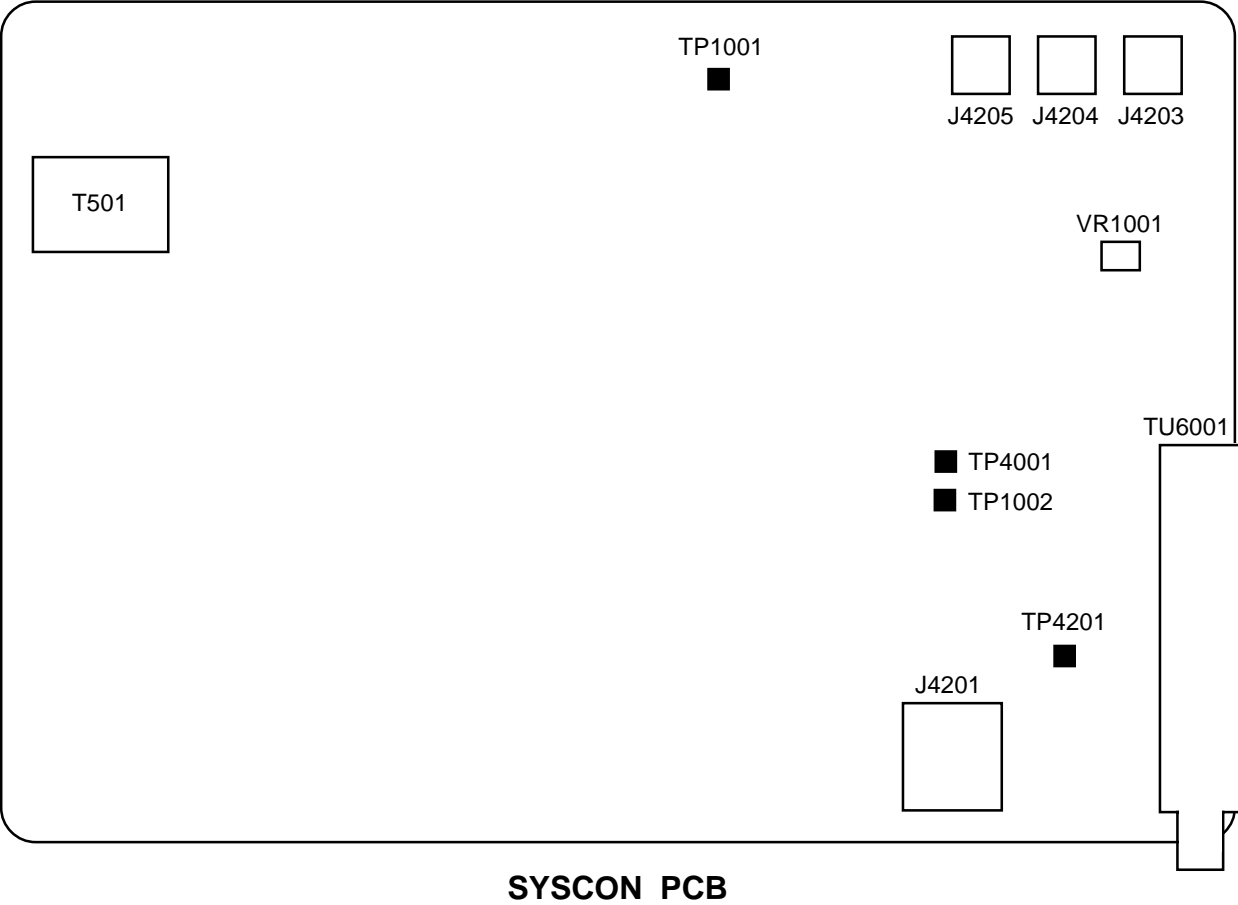

Y/C/AUDIO/CCD/HEAD AMP BLOCK DIAGRAM

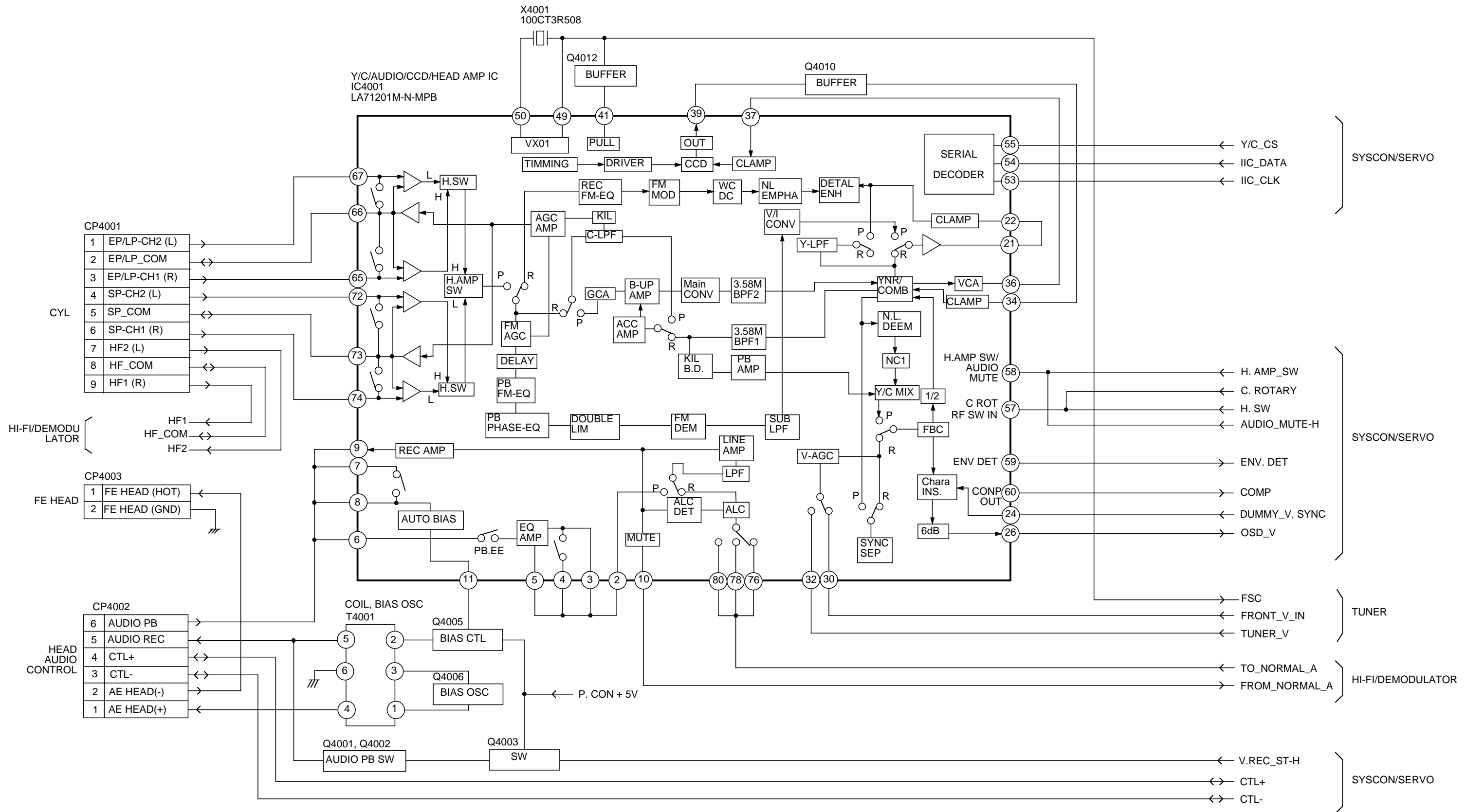

SYSTEM CONTROL/SERVO BLOCK DIAGRAM

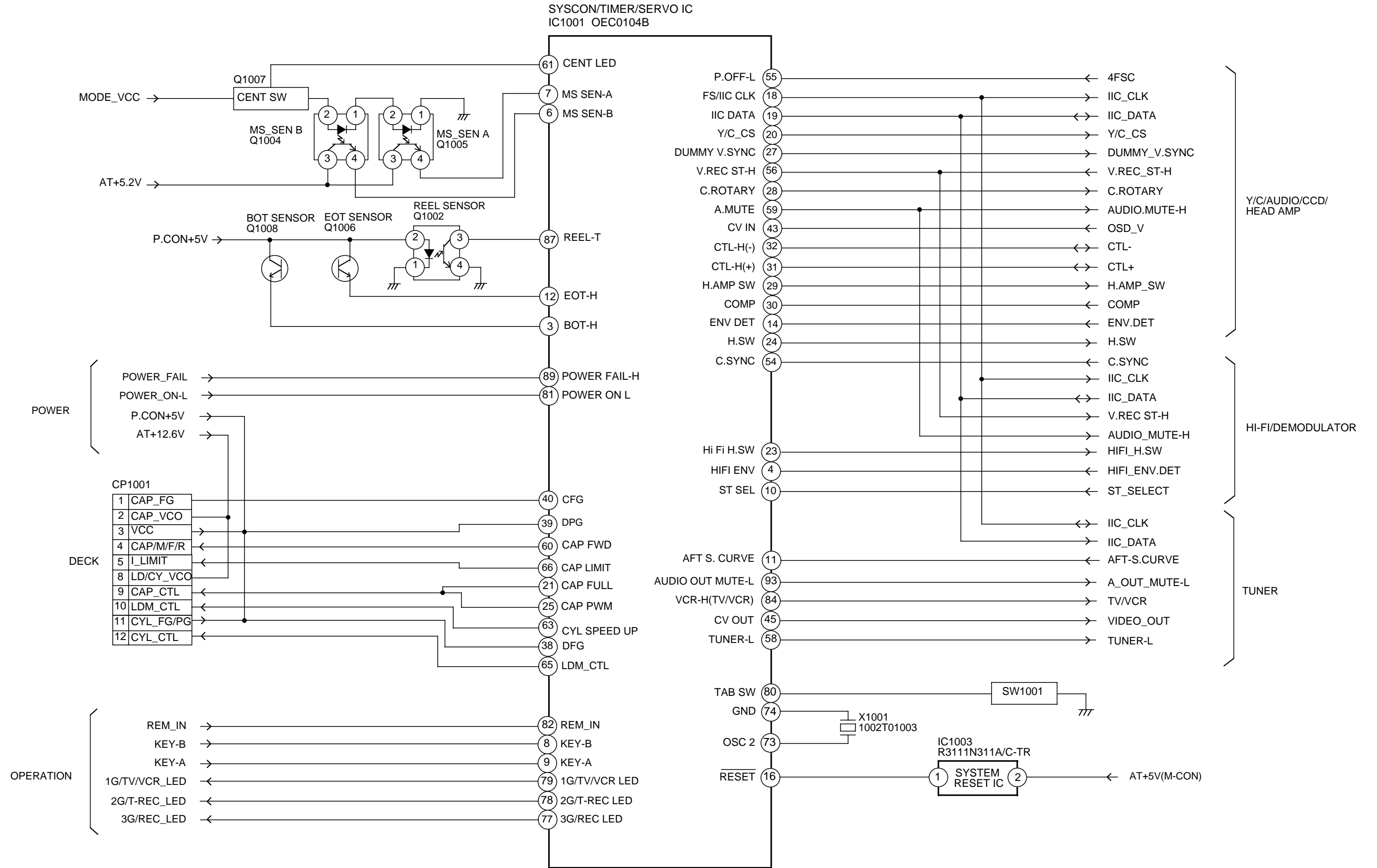

TUNER BLOCK DIAGRAM

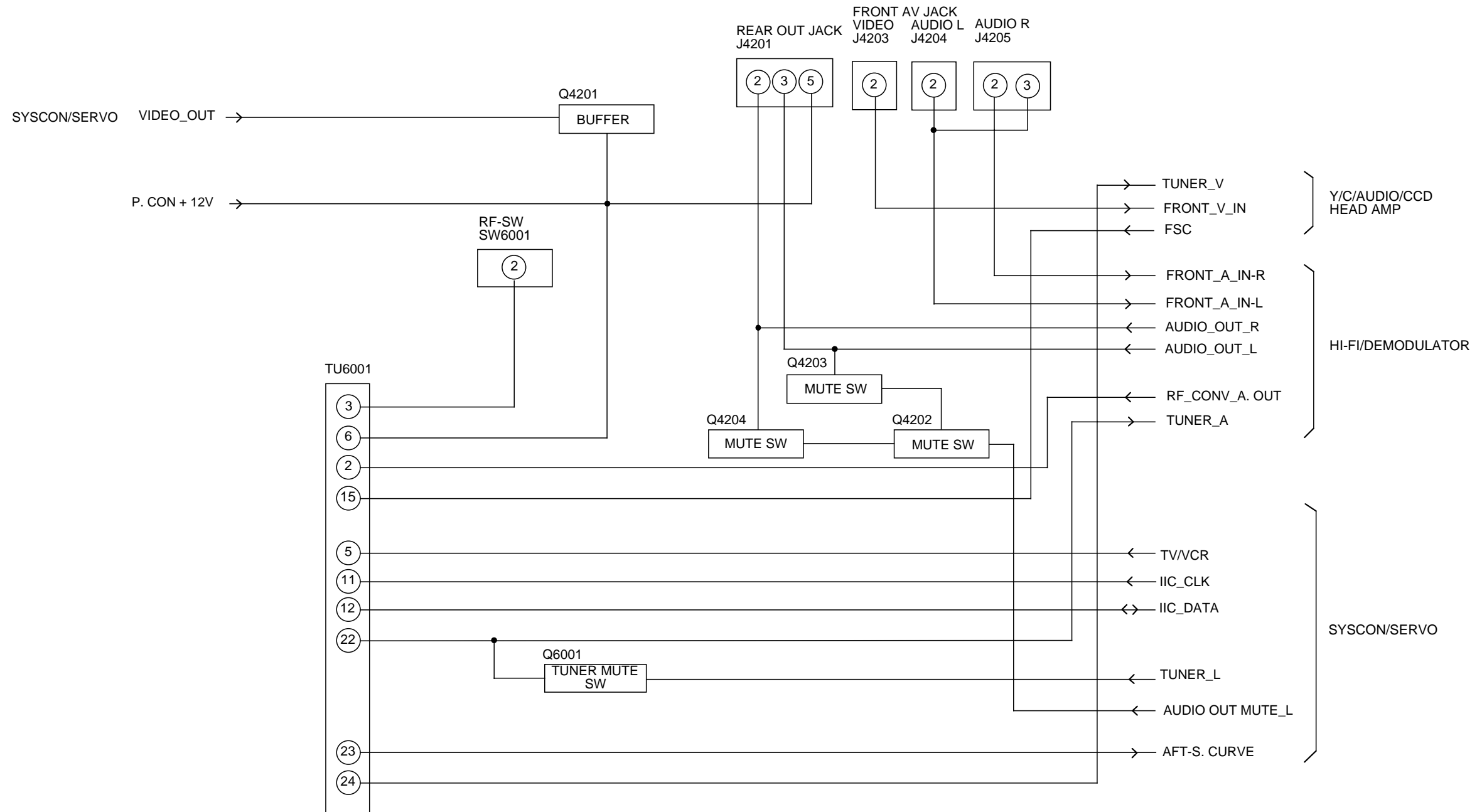

HI-FI/DEMODULATOR BLOCK DIAGRAM

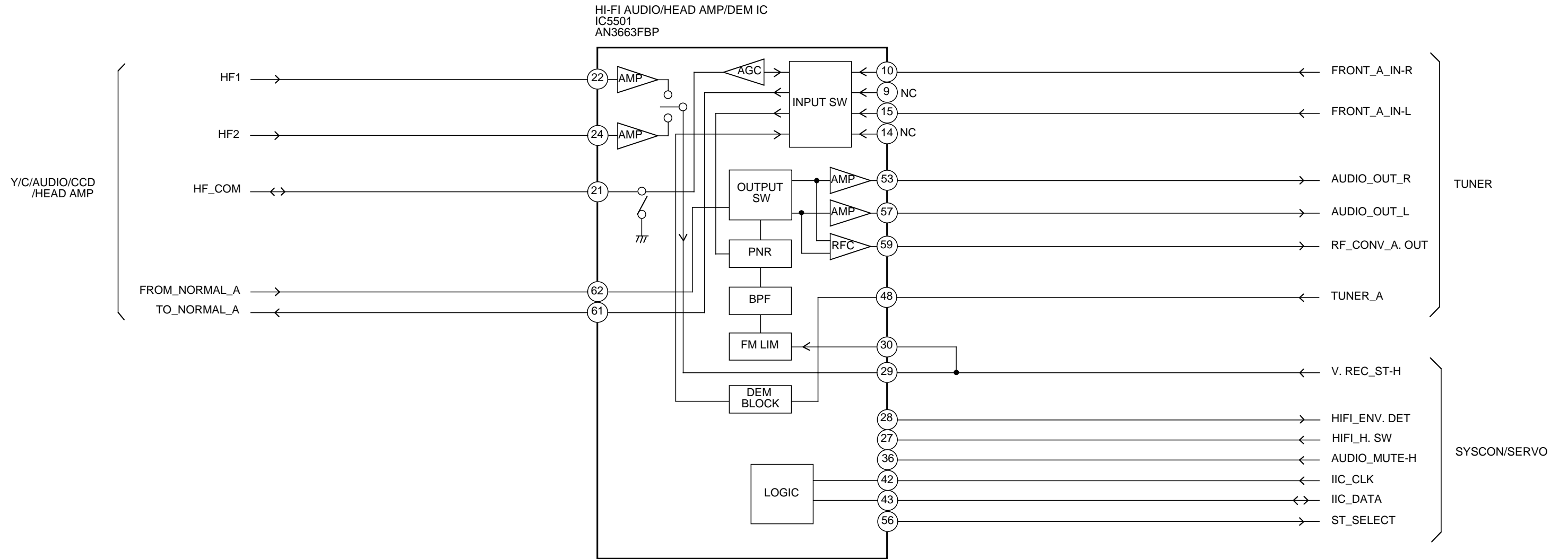

Y/C/AUDIO/CCD/HEAD AMP SCHEMATIC DIAGRAM (SYSCON PCB)

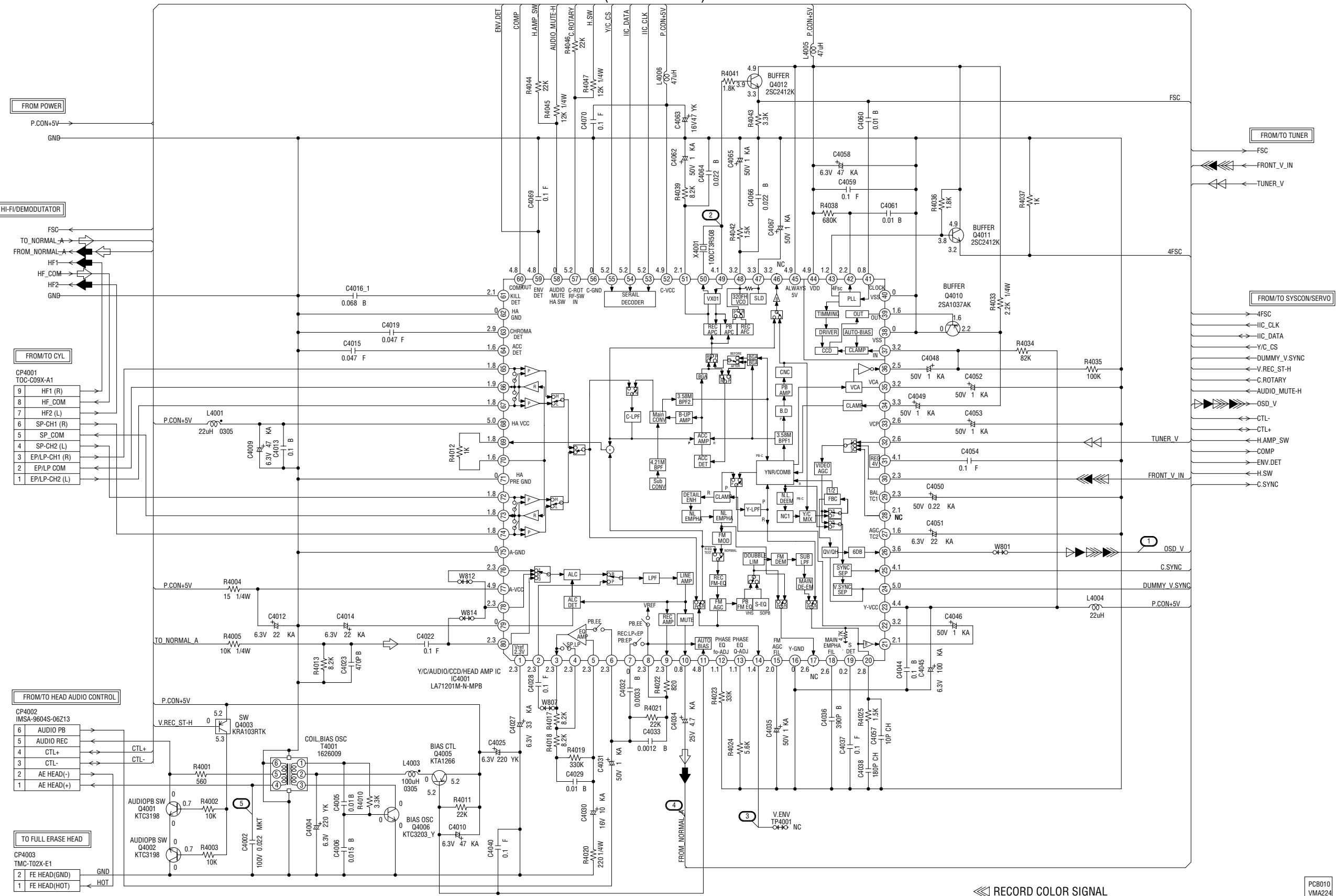

NOTE: THIS SCHEMATIC DIAGRAM IS THE LATEST AT THE TIME OF PRINTING AND SUBJECT TO CHANGE WITHOUT NOTICE.

NOTE: THE DC VOLTAGE AT EACH PART WAS MEASURED WITH THE DIGITAL TESTER DURING PLAYBACK.

CAUTION: DIGITAL TRANSISTOR

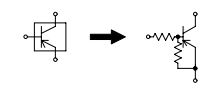

- ▶ RECORD COLOR SIGNAL
- ▶ RECORD LUMINANCE SIGNAL
- ▶ AUDIO SIGNAL (REC)
- ▶ AUDIO SIGNAL (PB)
- ▶ PLAYBACK COLOR SIGNAL
- ▶ PLAYBACK LUMINANCE SIGNAL
- ▶ TUNER VIDEO SIGNAL

PCB010
VMA224

SYSTEM CONTROL/SERVO SCHEMATIC DIAGRAM

(SYSCON PCB)

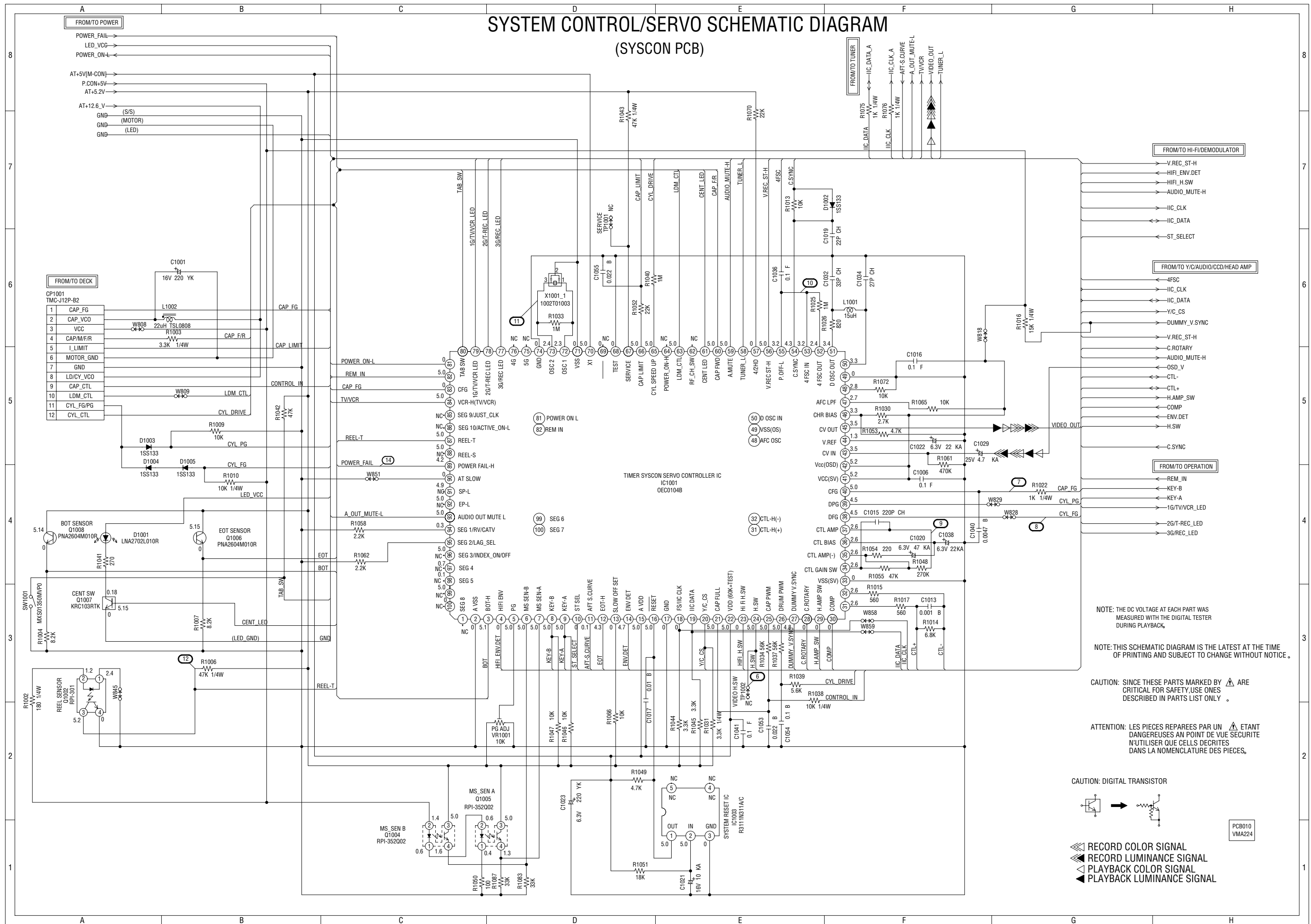

NOTE: THE DC VOLTAGE AT EACH PART WAS MEASURED WITH THE DIGITAL TESTER DURING PLAYBACK.

NOTE: THIS SCHEMATIC DIAGRAM IS THE LATEST AT THE TIME OF PRINTING AND SUBJECT TO CHANGE WITHOUT NOTICE.

CAUTION: SINCE THESE PARTS MARKED BY ARE CRITICAL FOR SAFETY, USE ONES DESCRIBED IN PARTS LIST ONLY.

ATTENTION: LES PIECES REPARÉES PAR UN ÉTANT DANGEREUSES AN POINT DE VUE SECURITE N'UTILISER QUE CELLS DÉCRITES DANS LA NOMENCLATURE DES PIECES.

CAUTION: DIGITAL TRANSISTOR



- RECORD COLOR SIGNAL
- RECORD LUMINANCE SIGNAL
- PLAYBACK COLOR SIGNAL
- PLAYBACK LUMINANCE SIGNAL

PCB010
VMA224

POWER SCHEMATIC DIAGRAM (SYSCON PCB)

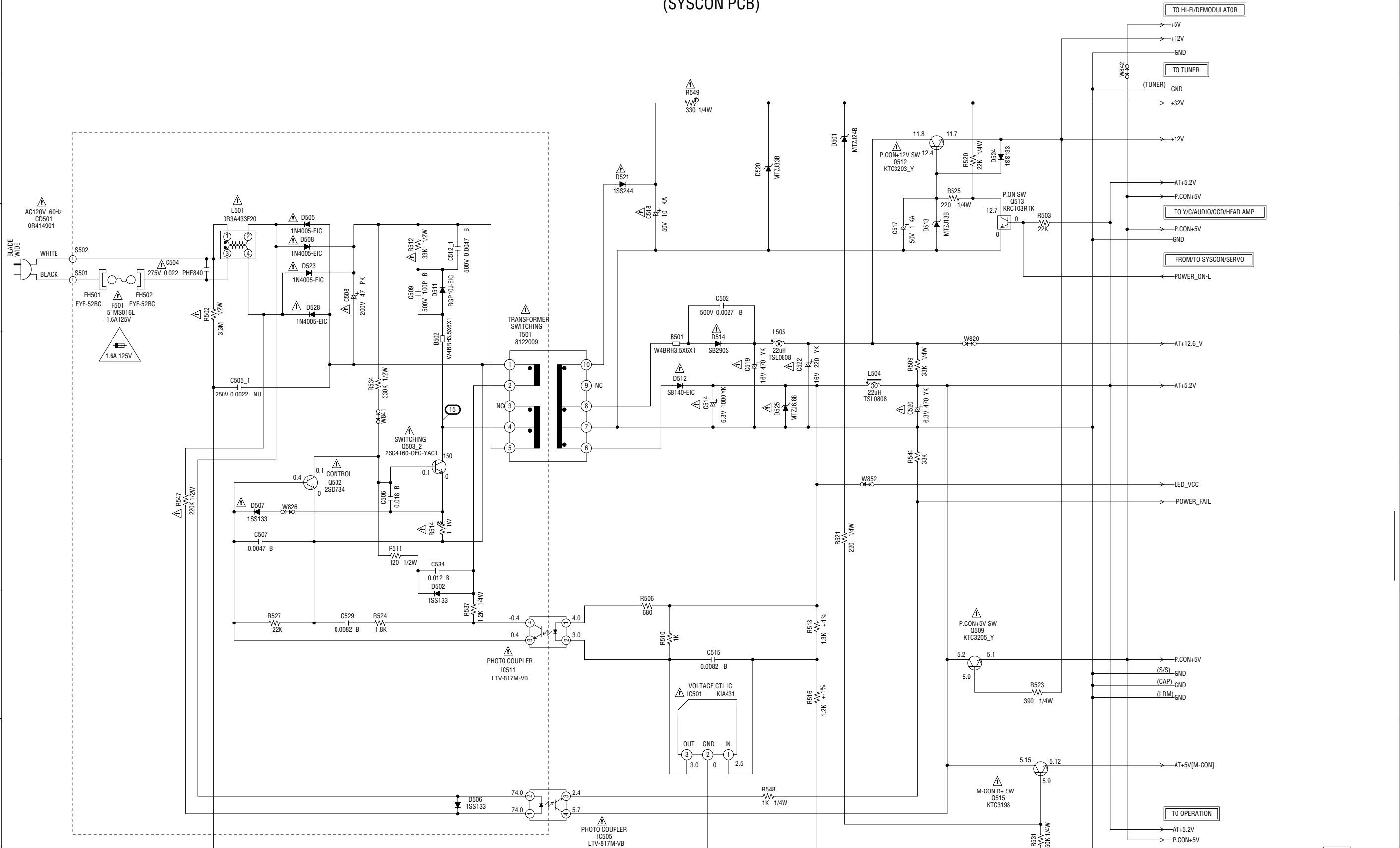

CAUTION: FOR CONTINUED PROTECTION AGAINST FIRE HAZARD, REPLACE ONLY WITH THE SAME TYPE FUSE 1.6A 125V (F501)
ATTENTION: POUR UNE PROTECTION CONTINUE LES RISQUES D'INCEIE UTILISER QUE DES FUSIBLE DE MEME TYPE 1.6A 125V (F501)

NOTE: THE DC VOLTAGE AT EACH PART WAS MEASURED WITH THE DIGITAL TESTER DURING PLAYBACK.

NOTE: THIS SCHEMATIC DIAGRAM IS THE LATEST AT THE TIME OF PRINTING AND SUBJECT TO CHANGE WITHOUT NOTICE.

ATTENTION: LES PIECES REPARÉES PAR UN ÉTANT DANGEREUSES AN POINT DE VUE SECURITE N'UTILISER QUE CELLS DECRITES DANS LA NOMENCLATURE DES PIECES.

CAUTION: SINCE THESE PARTS MARKED BY ARE CRITICAL FOR SAFETY, USE ONES DESCRIBED IN PARTS LIST ONLY.

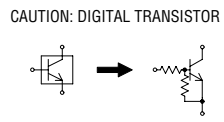

PCB010
VMA224

OPERATION SCHEMATIC DIAGRAM (SYSCON PCB)

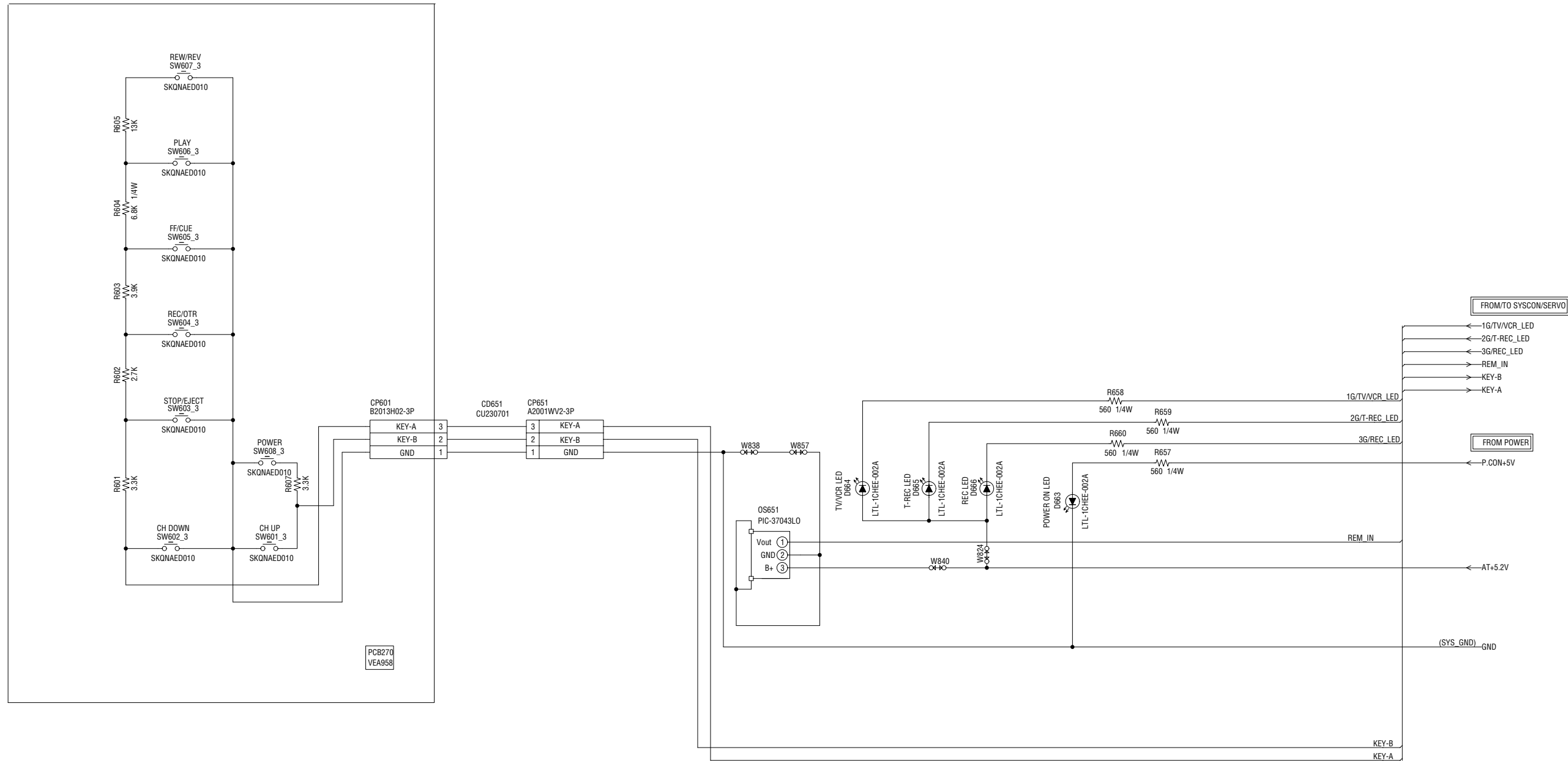

NOTE: THE DC VOLTAGE AT EACH PART WAS MEASURED WITH THE DIGITAL TESTER DURING PLAYBACK.

NOTE: THIS SCHEMATIC DIAGRAM IS THE LATEST AT THE TIME OF PRINTING AND SUBJECT TO CHANGE WITHOUT NOTICE.

PCB010
VMA224

TUNER SCHEMATIC DIAGRAM (SYSCON PCB)

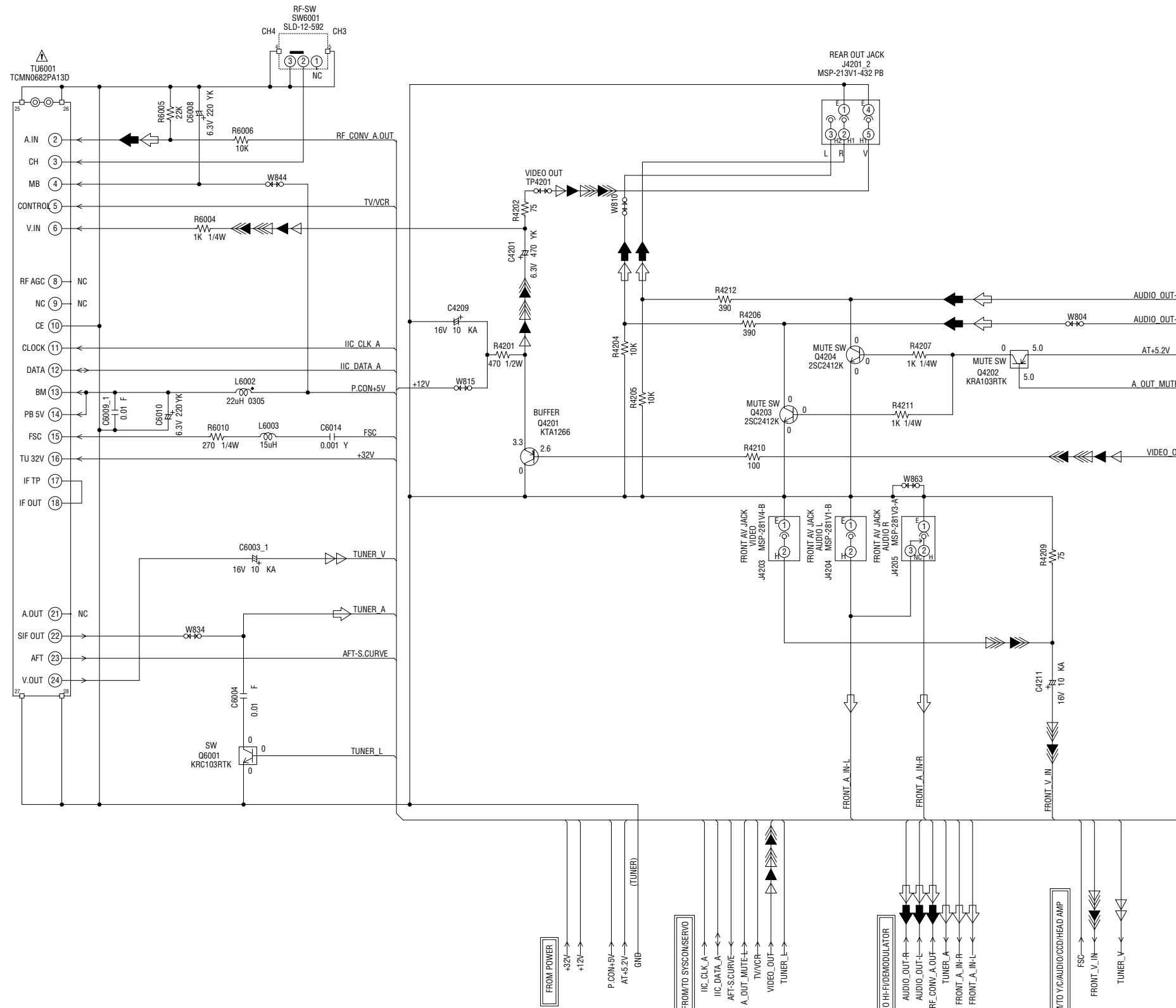

NOTE: THE DC VOLTAGE AT EACH PART WAS MEASURED WITH THE DIGITAL TESTER DURING PLAYBACK.

NOTE: THIS SCHEMATIC DIAGRAM IS THE LATEST AT THE TIME OF PRINTING AND SUBJECT TO CHANGE WITHOUT NOTICE.

CAUTION: SINCE THESE PARTS MARKED BY ARE CRITICAL FOR SAFETY, USE ONES DESCRIBED IN PARTS LIST ONLY.

ATTENTION: LES PIÈCES RÉPARÉES PAR UN ÉTANT DANGEREUSES AN POINT DE VUE SÉCURITÉ N'UTILISER QUE CELLES DÉCRITES DANS LA NOMENCLATURE DES PIÈCES.

CAUTION: DIGITAL TRANSISTOR

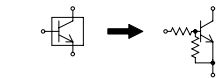

CAUTION: DIGITAL TRANSISTOR

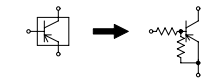

- RECORD LUMINANCE SIGNAL
- RECORD COLOR SIGNAL
- AUDIO SIGNAL(REC)
- AUDIO SIGNAL(PB)
- TUNER VIDEO SIGNAL
- PLAYBACK LUMINANCE SIGNAL
- PLAYBACK COLOR SIGNAL

PCB010
VMA224

HI-FI/DEMODULATOR SCHEMATIC DIAGRAM (SYSCON PCB)

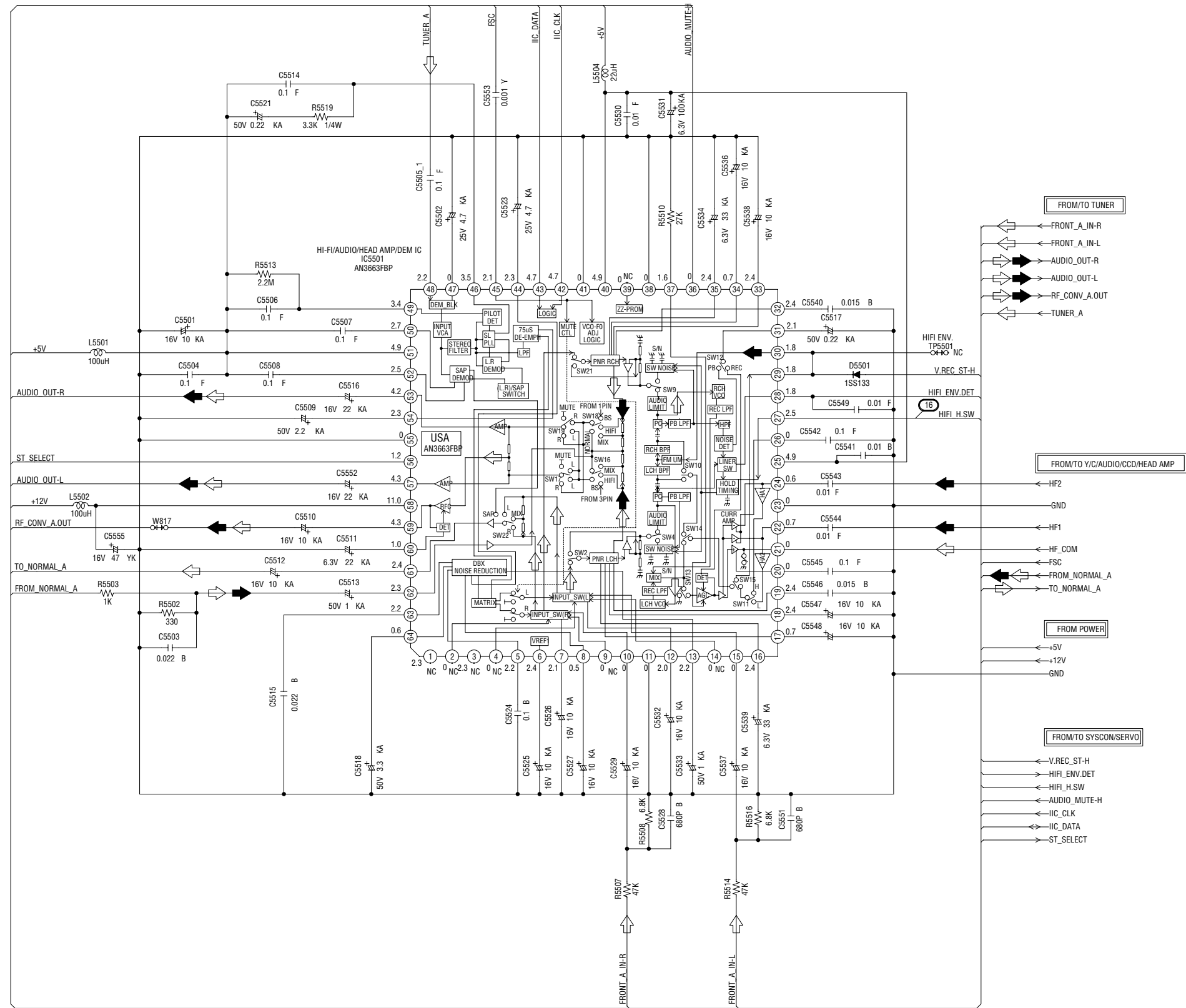

NOTE: THE DC VOLTAGE AT EACH PART WAS MEASURED WITH THE DIGITAL TESTER DURING PLAYBACK.

NOTE: THIS SCHEMATIC DIAGRAM IS THE LATEST AT THE TIME OF PRINTING AND SUBJECT TO CHANGE WITHOUT NOTICE.

◁ AUDIO SIGNAL (REC)
 ◀ AUDIO SIGNAL (PB)

PCB010
VMA224

INTERCONNECTION DIAGRAM

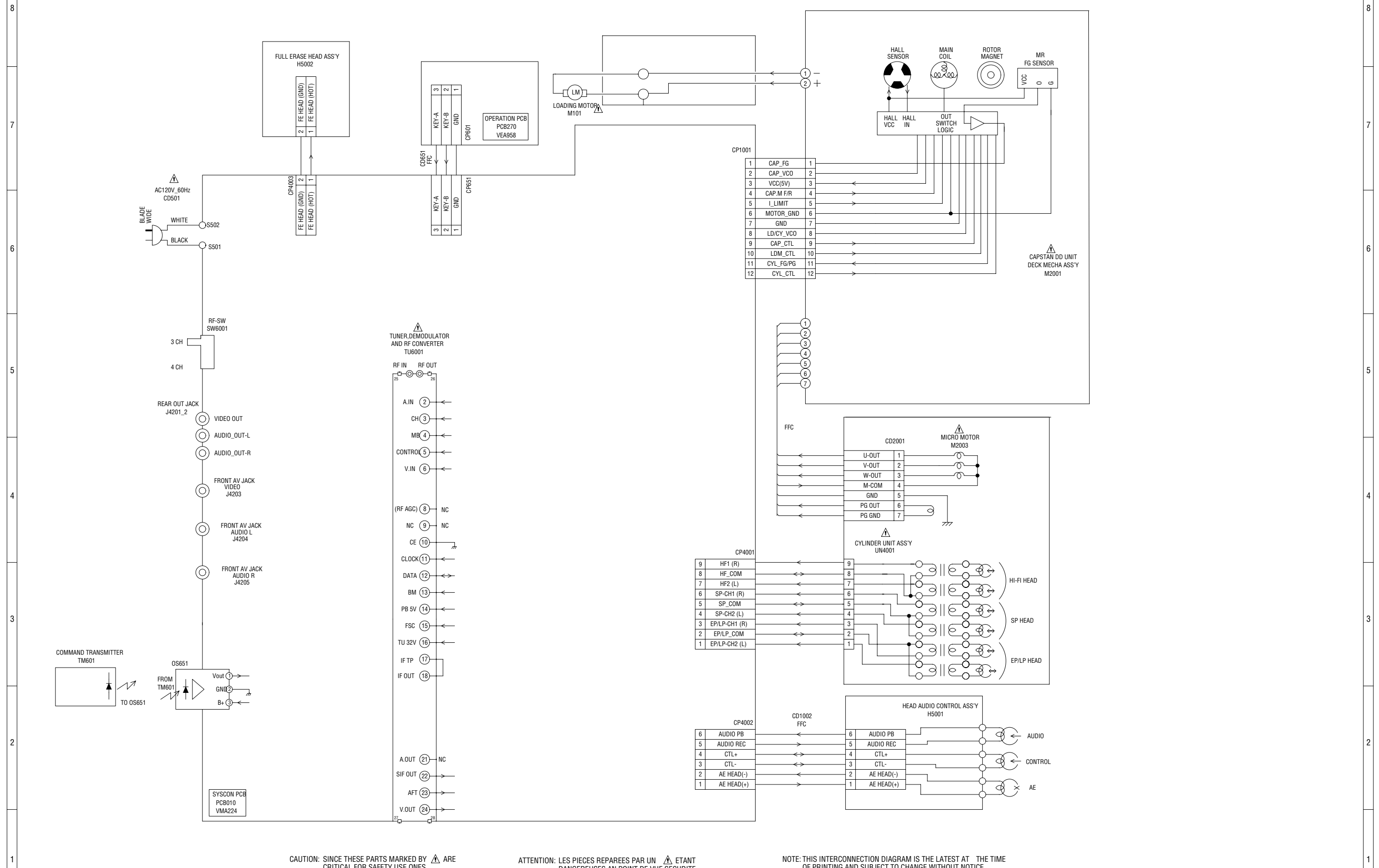

CAUTION: SINCE THESE PARTS MARKED BY ARE CRITICAL FOR SAFETY, USE ONES DESCRIBED IN PARTS LIST ONLY.

ATTENTION: LES PIÈCES RÉPARÉES PAR UN ÉTANT DANGEREUSES AU POINT DE VUE SÉCURITÉ N'UTILISER QUE CELLES DÉCRITES DANS LA NOMENCLATURE DES PIÈCES.

NOTE: THIS INTERCONNECTION DIAGRAM IS THE LATEST AT THE TIME OF PRINTING AND SUBJECT TO CHANGE WITHOUT NOTICE.

WAVEFORMS

Y/C/AUDIO/CCD/HEAD AMP

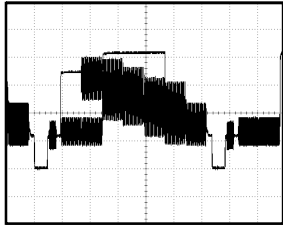

① POWER ON
10µs 500mV/div

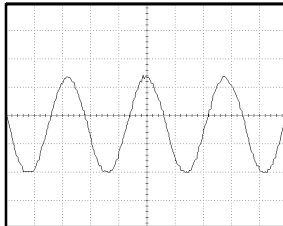

② POWER ON
100ns 100mV/div

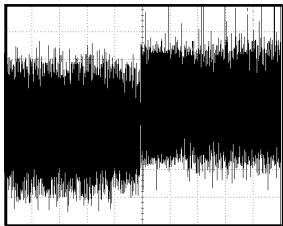

③ PB
1ms 100mV/div

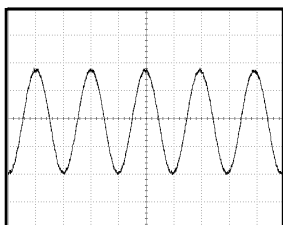

④ PB
500µs 200mV/div

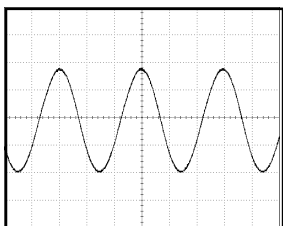

⑤ REC
5µs 20V/div

SYSCON/SERVO

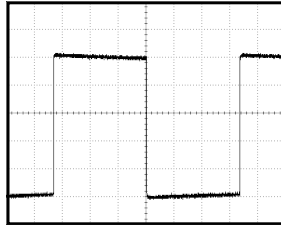

⑥ POWER ON
5ms 1.0V/div



⑦ PB
2µs 1.0V/div

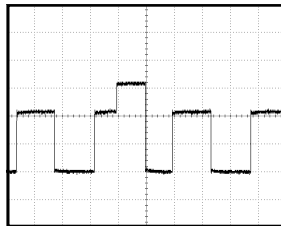

⑧ POWER ON
500µs 1.0V/div

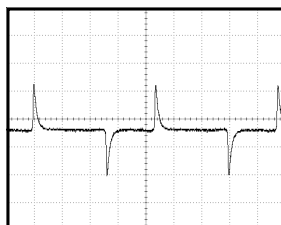

⑨ FF/REW
500µs 500mV/div

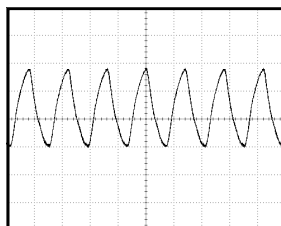

⑩ POWER ON
50ns 500mV/div

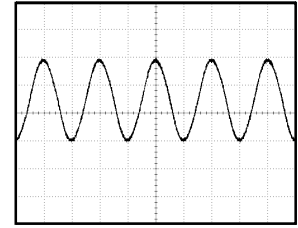

⑪ POWER ON
50ns 1.0V/div

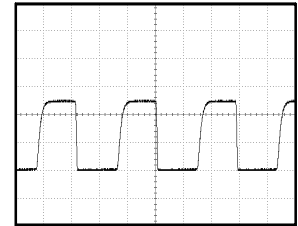

⑫ FF/REW
5ms 2V/div

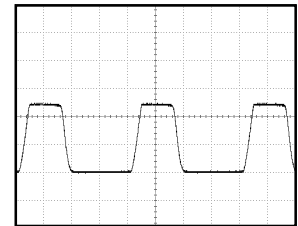

⑭ POWER OFF
5ms 2V/div

POWER

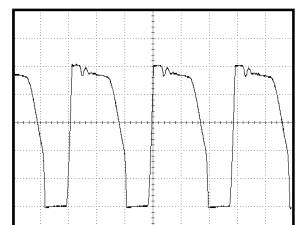

⑮ PB
2µs 50V/div

HI-FI/DEMODULATOR

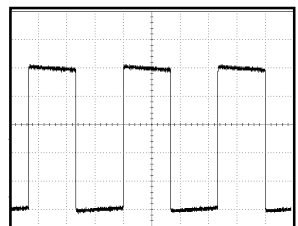

⑯ POWER ON
10ms 1.0V/div

NOTE: The following waveforms were measured at the point of the corresponding balloon number in the schematic diagram.

MECHANICAL EXPLODED VIEW

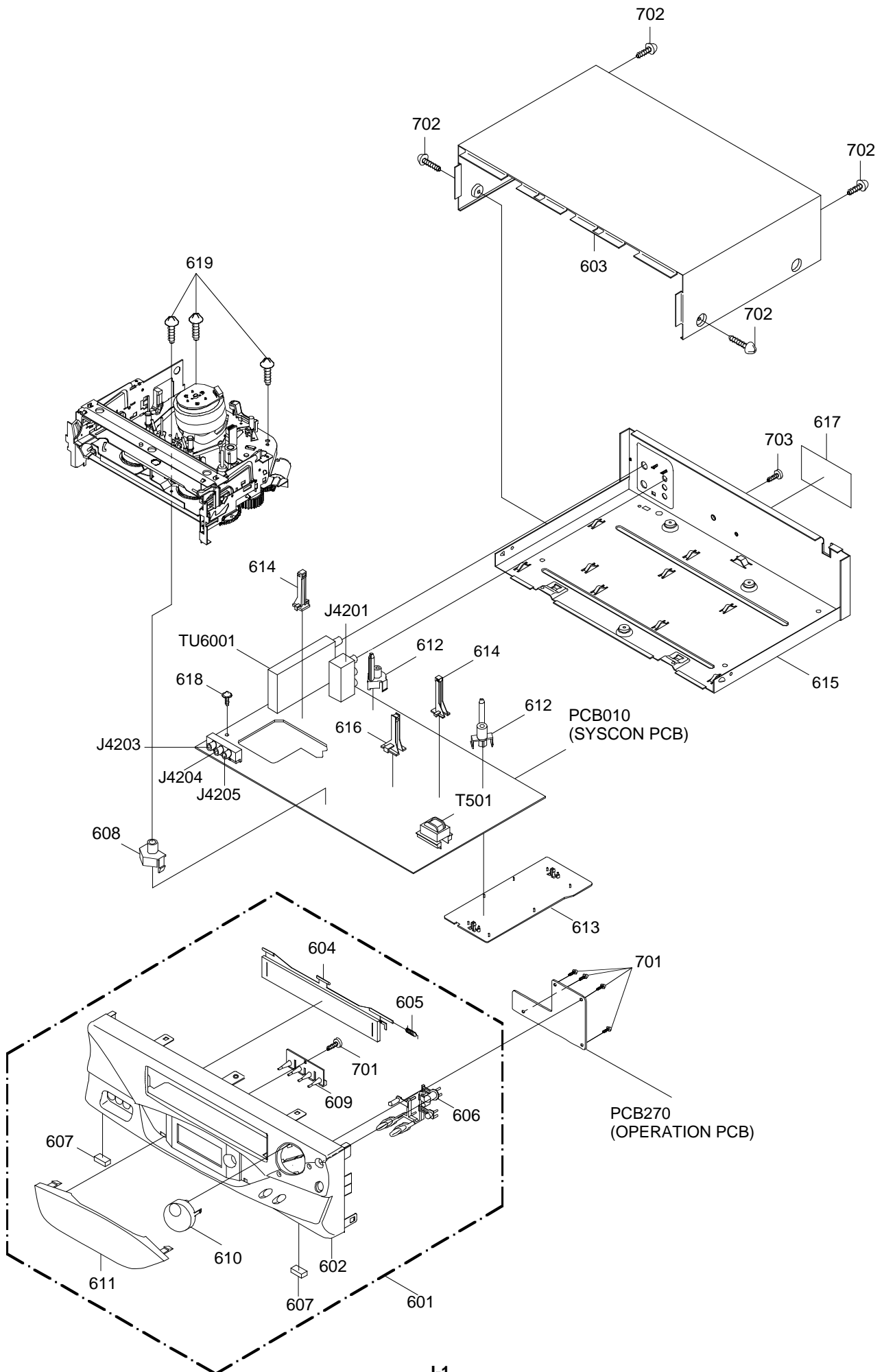

CHASSIS EXPLODED VIEW (TOP VIEW)

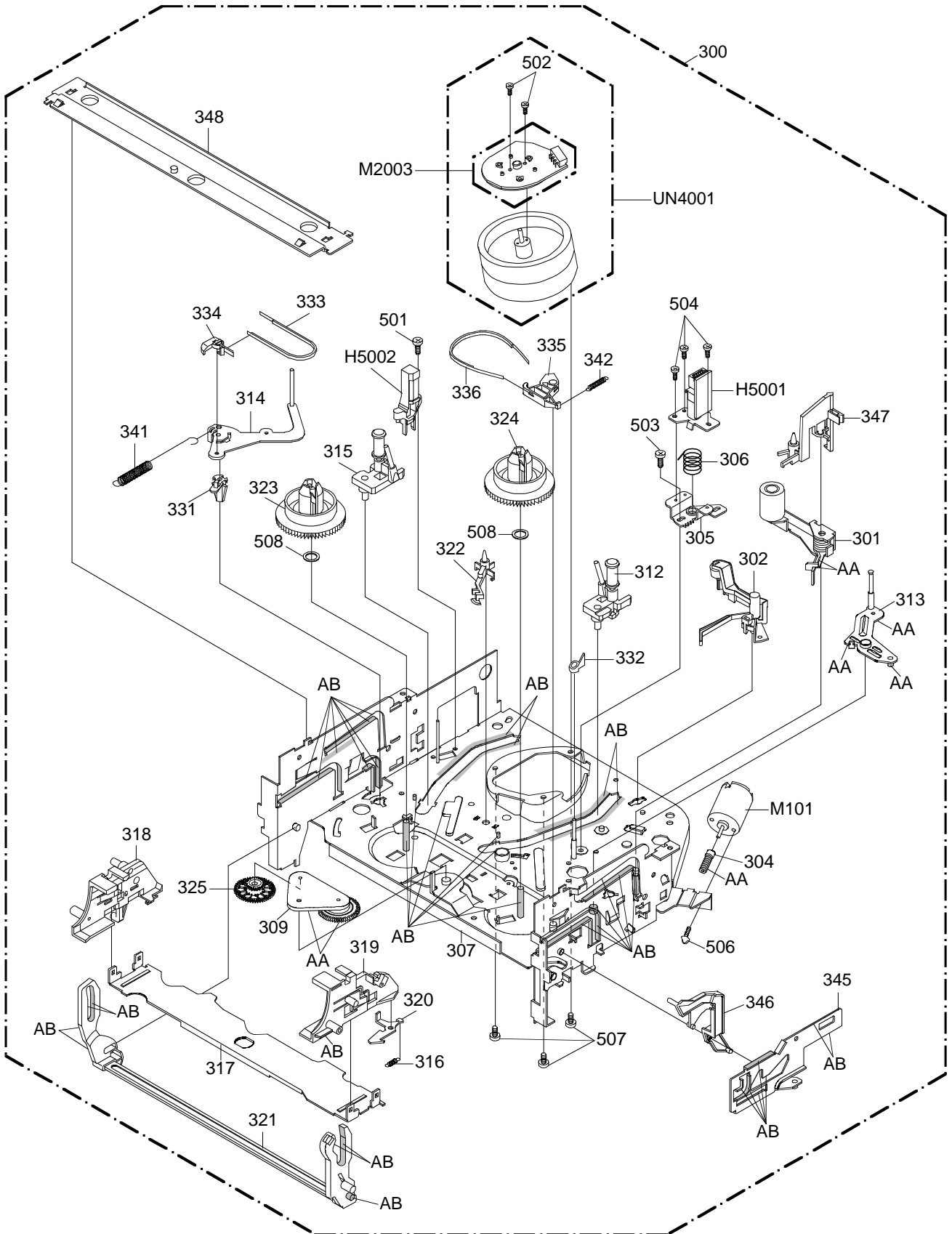

CLASS	PART NO.	MARK
GREASE	G-555G	AA
	MG-33	AB

NOTE: Applying positions AA and AB for the grease are displayed for this section. Check if the correct grease is applied for each position.

CHASSIS EXPLODED VIEW (BOTTOM VIEW)

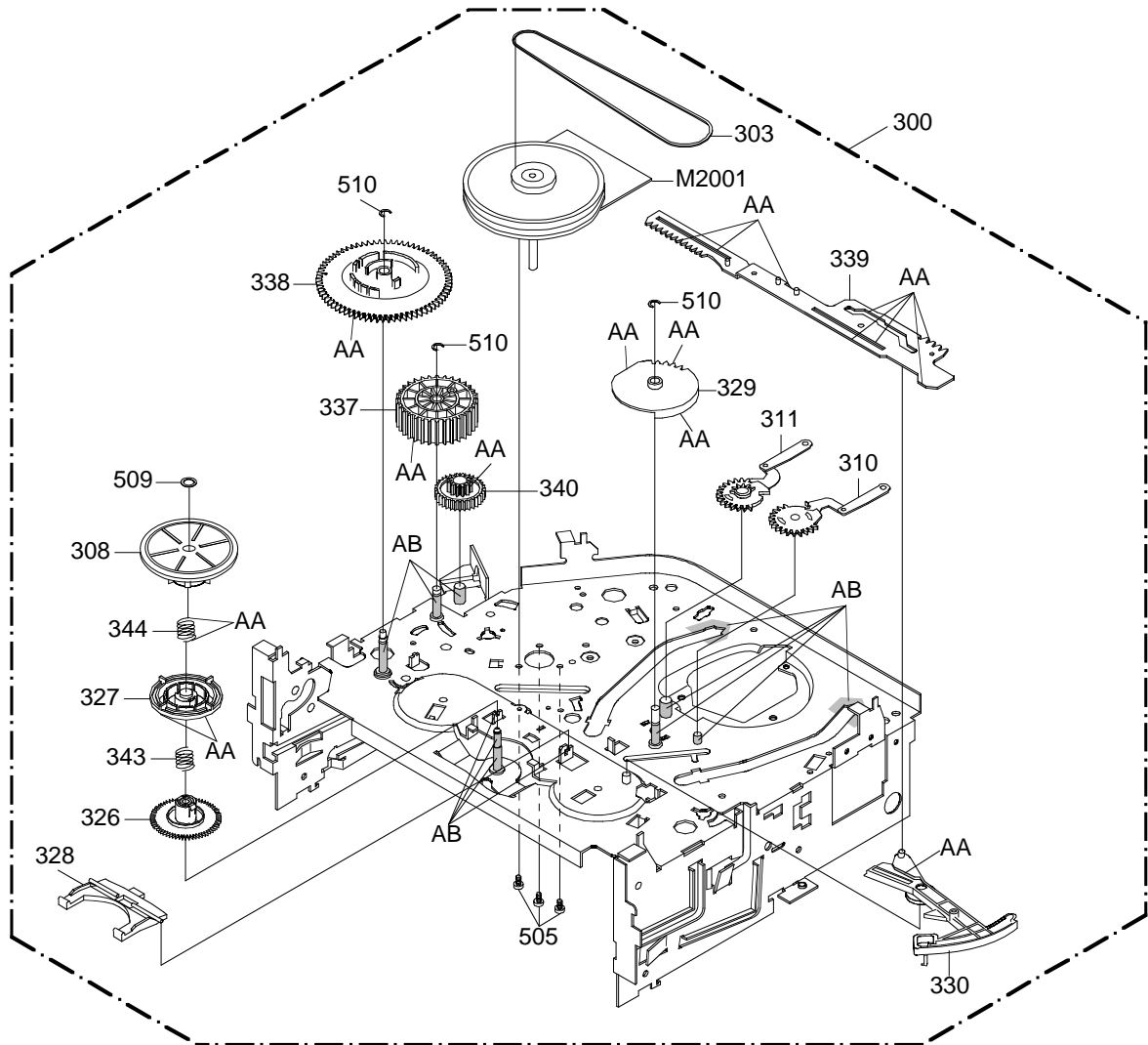

CLASS	PART NO.	MARK
GREASE	G-555G	AA
	MG-33	AB

NOTE: Applying positions AA and AB for the grease are displayed for this section. Check if the correct grease is applied for each position.

MECHANICAL REPLACEMENT PARTS LIST

REF. NO.	PART NO.	DESCRIPTION		
601	A4F210B720	CABINET,FRONT ASS'Y		
602	701WPJB416	CABINET,FRONT		
603	702WSB0058	CABINET,TOP		
604	712WPJB163	FLAP		
605	743WKA0032	SPRING,FLAP (COMBO)		
606	735WPAA216	BUTTON,FRAME		
607	800WFA0045	CUSHION,LEG		
608	701WPA0686	HOLDER,DECK		
609	713WPAA037	GLASS,LED		
610	735WPDA445	BUTTON,PLAY/STOP		
611	711WPDA389	PLATE,DISPLAY		
612	701WPA0680	HOLDER,DECK		
613	755WPA0020	PLATE,COVER POWER		
614	85OP700036	HOLDER,EOT SENSOR		
615	702WSA0083	PLATE,BOTTOM		
616	85OP700037	HOLDER,LED		
617	722A08A090	SHEET,RATING		
618	8109230704	SCREW,TAP TITE (B)R	BIND	3x7
619	8109130B94	SCREW,TAP TITE (B)R	PAN	3x29
701	8110226804	SCREW,TAP TITE (P)	BIND	2.6x8
702	8109230802	SCREW,TAP TITE (B)		3x8
703	8110230804	SCREW,TAP TITE (P)	BIND	3x8
---	JA5U0100	POLYBAG		
---	J4F21001	INSTRUCTION BOOK		
---	A4F210B975	INSTRUCTION BOOK KIT		
---	791WHA0095	GIFT,SHEET		
---	792WHA0306	PACKAGE		
---	793WCDB048	GIFT BOX		

CHASSIS REPLACEMENT PARTS LIST

REF. NO.	PART NO.	DESCRIPTION	REF. NO.	PART NO.	DESCRIPTION
300	A4F201B420K	DECK ASSY A4F201B420K	501	8107226804	SCREW,TAP TITE(S) BIND 2.6x8
301	85OA400227	PINCH ROLLER BLOCK	502	8107226504	SCREW,TAP TITE(S) BIND 2.6x5
302	85OA500026	AHC ASS'Y	503	8107226404	SCREW,TAP TITE(S) BIND 2.6x4
303	85OP200290	BELT,CAPSTAN (S)	504	8102120604	SCREW,PAN M2x6
304	85OP600581	WORM	505	8109126604	SCREW,TAP TITE(B) PAN 2.6x6
305	85OP500083	BASE,AC HEAD	506	810A130404	SCREW/WASHER(A) M3x4
306	85OP800324	SPRING,AC HEAD	507	810A126504	SCREW/WASHER(A) M2.6x5
307	85OA000459	MAIN CHASSIS ASS'Y	508	82Q264713N	POLYSLIDER WASHER 2.6x4.7xT0.13
308	85OA200089	CLUTCH ASS'Y	509	82P184505N	POLYSLIDER WASHER(CUT) 1.8x4.5xT0.5
309	85OA200090	ARM IDLER ASS'Y	510	83ETW30000	E-RING 3.0
310	85OA300065	LOADING ARM S UNIT	CD1501	122H071603	CORD JUMPER SMCD-7X151
311	85OA300066	LOADING ARM T UNIT	CD1502	122Y021902	CORD JUMPER 2Y021902
312	85OA400223	INCLINED BASE T UINIT 3S	H5001	1523D91034	HEAD (AUDIO CONTROL) HVMXA1072A
313	85OA400226	P5 ARM ASS'Y	H5002	1543D02013	HEAD (FULL ERASE) HVFHP0032A
314	85OA400230	TENSION ARM ASS'Y	△ M101	1596P98001	MOTOR (LOADING) MXN13FB12K3
315	85OA400231	INCLINED BASE S UNIT	△ M2001	1510S98035	CAPSTAN DD UNIT F2QVB01-C
316	85OP800358	SPRING,LOCKER	△ M2003	1589S11015	MICRO MOTOR I2OAL01
317	85OP900736	CASS,HOLDER	△ UN4001	A4F201B500	CYLINDER UNIT ASS'Y A4F201B500
318	85OP900737	CASS,SIDE L			
319	85OP900738	CASS,SIDE R			
320	85OP900739	LOCKER,R			
321	85OA900228	LINK UNIT			
322	85OP000496	POST,CASS GUIDE			
323	85OP200291	REEL,S (S)			
324	85OP200292	REEL,T (S)			
325	85OP200308	GEAR,IDLER			
326	85OP200311	GEAR,CLUTCH			
327	85OP200312	GEAR,COUPLING			
328	85OP200313	LEVER,CLUTCH			
329	85OP300194	GEAR,MAIN LOADING			
330	85OP400490	LEVER,TENSION			
331	85OP400492	HOLDER,TENSION			
332	85OP400520	CAP.P4			
333	85OP400532	BAND,TENSION			
334	85OP400533	CONNECT,TENSION			
335	85OP600573	ARM,BRAKE T			
336	85OP600574	BAND,BRAKE T			
337	85OP600577	CAM,PINCH ROLLER			
338	85OP600578	CAM,MAIN			
339	85OP600579	ROD,MAIN			
340	85OP600582	GEAR,JOINT			
341	85OP800322	SPRING,TENSION			
342	85OP800350	SPRING,BRAKE T			
343	85OP800355	SPRING,COUPLING			
344	85OP800356	SPRING,RING			
345	85OP900743	LEVER,LINK			
346	85OP900744	LEVER,FLAP			
347	85OP900745	CASS,OPENER			
348	85OP900746	BRACKET,TOP 3V			

ELECTRICAL REPLACEMENT PARTS LIST

REF. NO.	PART NO.	DESCRIPTION	REF. NO.	PART NO.	DESCRIPTION
RESISTORS			COILS & TRANSFORMERS		
▲ R502	R0G3K2335K	RC 3.3M OHM 1/2W	▲ L501	029T000083	COIL,LINE FILTER 0R3A433F20
▲ R512	R002T2333J	RC 33K OHM 1/2W	L504	02167E220K	COIL 22 UH or
▲ R514	R3X181010J	R,METAL OXIDE 1 OHM 1W		021W7A220K	COIL 22 UH
▲ R547	R002T2224J	RC 220K OHM 1/2W	L505	02167E220K	COIL 22 UH or
▲ R549	R65584331J	R,FUSE 330 OHM 1/4W		021W7A220K	COIL 22 UH
CAPACITORS			L1001	0216A6150K	COIL 15 UH
▲ C504	P2472B223M	CMP 0.022 UF 275V PHE840	L1002	02167E220K	COIL 22 UH or
▲ C505	CBLLYEMH3M	CC 0.0022UF 250V		021W7A220K	COIL 22 UH
▲ C508	E62QFC470M	CE 47 UF 200V	L4001	02167F220J	COIL 22 UH
▲ C514	E02LT0102M	CE 1000 UF 6.3V	L4003	02167F101J	COIL 100 UH
▲ C518	E50HU5100M	CE 10 UF 50V	L4004	0216A6220K	COIL 22 UH
▲ C519	E02LT2471M	CE 470 UF 16V	L4005	0216A6470K	COIL 47 UH
▲ C520	E02LU0471M	CE 470 UF 6.3V	L4006	0216A6470K	COIL 47 UH
▲ C522	E02LU2221M	CE 220 UF 16V	L5501	0216A6101K	COIL 100 UH
DIODES			L5502	0216A6101K	COIL 100 UH
D501	D97U02401B	DIODE,ZENER MTZJ24B T-77	L5504	0216A6220K	COIL 22 UH
D502	D1VT001330	DIODE,SILICON 1SS133T-77	L6002	02167F220J	COIL 22 UH
▲ D505	D2WXN40050	DIODE,SILICON 1N4005-EIC	L6003	0216A6150K	COIL 15 UH
D506	D1VT001330	DIODE,SILICON 1SS133T-77	▲ T501	0481220094	TRANSFORMER,SWITCHING 8122009
▲ D507	D1VT001330	DIODE,SILICON 1SS133T-77	T4001	031626009R	COIL,BIAS OSC 1626009
▲ D508	D2WXN40050	DIODE,SILICON 1N4005-EIC	JACKS		
D511	D2WXGP10J0	DIODE,RECTIFIER RGP10J-EIC	J4201	060J411018	RCA,JACK MSP-213V1-432 PBSN
▲ D512	D2WXS1400	DIODE,SCHOTTKY SB140-EIC	J4203	060J401079	RCA,JACK MSP-281V4-B
D513	D97U01301B	DIODE,ZENER MTZJ13B T-77	J4204	060J401080	RCA,JACK MSP-281V1-B
▲ D514	D2WXB290S0	DIODE,SILICON SB290S	J4205	060J421023	RCA,JACK MSP-281V3-A
D520	D97U03301B	DIODE,ZENER MTZJ33B T-77	SWITCHES		
▲ D521	D17T002440	DIODE,SILICON 1SS244T-77	SW601	0504201T32	SWITCH,TACT SKQNAED010
▲ D523	D2WXN40050	DIODE,SILICON 1N4005-EIC	SW602	0504201T32	SWITCH,TACT SKQNAED010
D524	D1VT001330	DIODE,SILICON 1SS133T-77	SW603	0504201T32	SWITCH,TACT SKQNAED010
▲ D525	D97U06R81B	DIODE,ZENER MTZJ6.8B T-77	SW604	0504201T32	SWITCH,TACT SKQNAED010
▲ D528	D2WXN40050	DIODE,SILICON 1N4005-EIC	SW605	0504201T32	SWITCH,TACT SKQNAED010
D663	0021E2Q140	LED LTL-1CHEE-002A	SW606	0504201T32	SWITCH,TACT SKQNAED010
D664	0021E2Q140	LED LTL-1CHEE-002A	SW607	0504201T32	SWITCH,TACT SKQNAED010
D665	0021E2Q140	LED LTL-1CHEE-002A	SW608	0504201T32	SWITCH,TACT SKQNAED010
D666	0021E2Q140	LED LTL-1CHEE-002A	SW1001	0508A11001	SWITCH(LEAF) MXS01350MVP0
D1001	0010100320	INFRARED LED LNA2702L010R	SW6001	0510S21041	SWITCH SLIDE SLD-12-592
D1002	D1VT001330	DIODE,SILICON 1SS133T-77	VARIABLE RESISTOR		
D1003	D1VT001330	DIODE,SILICON 1SS133T-77	VR1001	V116314BTC	VOLUME,SEMI FIXED EVNVCYAA03B14
D1004	D1VT001330	DIODE,SILICON 1SS133T-77	P.C.BOARD ASSEMBLIES		
D1005	D1VT001330	DIODE,SILICON 1SS133T-77	PCB010	A4F210B010	PCB ASS'Y VMA224A
D5501	D1VT001330	DIODE,SILICON 1SS133T-77	PCB270	A4F212B270	PCB ASS'Y VEA958A
ICS			MISCELLANEOUS		
▲ IC501	I1KJ9A4310	IC KIA431	B501	024HT03564	CORE,BEADS W4BRH3.5X6X1
IC505	0002E00610	PHOTO COUPLER LTV-817M-VB	B502	024HT03564	CORE,BEADS W4BRH3.5X6X1
IC511	0002E00610	PHOTO COUPLER LTV-817M-VB	▲ CD501	120R414901	CORD,AC BUSH 0R414901
IC1001	I54F50104B	IC OEC0104B	CD651	06CU230701	CORD,JUMPER CU230701
IC1003	IC7J0311A0	IC R3111N311A/C-TR	CP601	067U003029	WIRE HOLDER B2013H02-3P
IC4001	I03F301MN0	IC LA71201M-N-MPB	CP651	069S230629	CONNECTOR PCB SIDE A2001WV2-3P
IC5501	I01F63FBP0	IC AN3663FBP	CD1002	122F061501	CORD,JUMPER 2F061501
TRANSISTORS			CD6002	06CQL02006	CABLE SI-C108-40
▲ Q502	TD3T007340	TRANSISTOR,SILICON 2SD734(E,F)-AA	CP1001	06972C0010	CONNECTOR PCB SIDE TMC-J12P-B2
▲ Q503	TCWQ4160E0	TRANSISTOR,SILICON 2SC4160-OEC-YAC1	CP4001	0697290620	CONNECTOR PCB SIDE TOC-C09X-A1
▲ Q509	TCAT03205Y	TRANSISTOR,SILICON KTC3205_Y-AT	CP4002	069J760019	CONNECTOR PCB SIDE IMSA-9604S-06Z13
▲ Q512	TCAT032034	TRANSISTOR,SILICON KTC3203_Y-AT	CP4003	0697120320	CONNECTOR PCB SIDE TMC-T02X-E1
	TC5T021204	TRANSISTOR,SILICON 2SC2120Y(TPE2)	▲ F501	081PC1R605	FUSE 51MS016L
Q513	TNAAC05002	COMPOUND TRANSISTOR KRC103RTK	FH501	06710T0006	HOLDER,FUSE EYF-52BC
▲ Q515	TCATC31980	TRANSISTOR,SILICON KTC3198-AT(Y,GR)	FH502	06710T0006	HOLDER,FUSE EYF-52BC
Q1002	0002700590	PHOTO COUPLER RPI-301	OS651	077Q037001	REMOTE RECEIVER PIC-37043LO
Q1004	0002700670	PHOTO COUPLER RPI-352Q02	TM601	076N0EA040	TRANSMITTER RC-EA040
Q1005	0002700670	PHOTO COUPLER RPI-352Q02	▲ TU6001	0162K00021	RF,UNIT TCMN0682PA13D
Q1006	0000100380	PHOTO TRANSISTOR PNA2604M010R	X1001	1002T01003	CERAMIC OSCILLATOR CSTS1000MG96004-T2
Q1007	TNAAC05002	COMPOUND TRANSISTOR KRC103RTK	X4001	100CT3R508	CRYSTAL HC-49/U 3.579545MHz
Q1008	0000100380	PHOTO TRANSISTOR PNA2604M010R	RESISTOR		
Q4001	TCATC31980	TRANSISTOR,SILICON KTC3198-AT(Y,GR)	RC..... CARBON RESISTOR		
Q4002	TCATC31980	TRANSISTOR,SILICON KTC3198-AT(Y,GR)	CAPACITORS		
Q4003	TPAAC05002	COMPOUND TRANSISTOR KRA103RTK	CC..... CERAMIC CAPACITOR		
Q4005	TAATA12660	TRANSISTOR,SILICON KTA1266-AT(Y,GR)	CE..... ALUMI ELECTROLYTIC CAPACITOR		
Q4006	TCAT032034	TRANSISTOR,SILICON KTC3203_Y-AT	CP..... POLYESTER CAPACITOR		
	TC5T021204	TRANSISTOR,SILICON 2SC2120Y(TPE2)	CPP..... POLYPROPYLENE CAPACITOR		
Q4010	T6YJ1037K0	TRANSISTOR,SILICON 2SA1037AKT146R,S	CPL..... PLASTIC CAPACITOR		
Q4011	T8YJ2412K0	TRANSISTOR,SILICON 2SC2412KT146R,S	CMP..... METAL POLYESTER CAPACITOR		
Q4012	T8YJ2412K0	TRANSISTOR,SILICON 2SC2412KT146R,S	CMPL..... METAL PLASTIC CAPACITOR		
Q4201	TAATA12660	TRANSISTOR,SILICON KTA1266-AT(Y,GR)	CMPP..... METAL POLYPROPYLENE CAPACITOR		
Q4202	TPAAC05002	COMPOUND TRANSISTOR KRA103RTK			
Q4203	T8YJ2412K0	TRANSISTOR,SILICON 2SC2412KT146R,S			
Q4204	T8YJ2412K0	TRANSISTOR,SILICON 2SC2412KT146R,S			
Q6001	TNAAC05002	COMPOUND TRANSISTOR KRC103RTK			

SPEC.NO.	M4F2-10B
O/R NO.	K184002

Memorex[®]

MVR4051

SERVICE MANUAL

VIDEO CASSETTE RECORDER

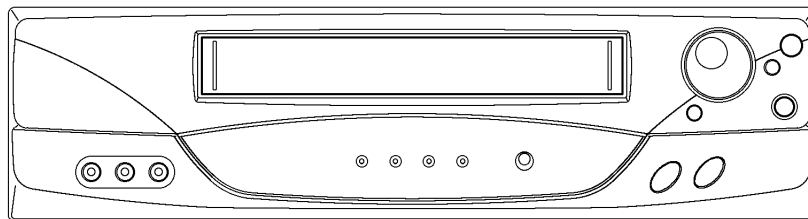

VHS

**ORIGINAL
MFR'S VERSION B**

SERVICING NOTICES ON CHECKING

1. KEEP THE NOTICES

As for the places which need special attentions, they are indicated with the labels or seals on the cabinet, chassis and parts. Make sure to keep the indications and notices in the operation manual.

2. USE THE DESIGNATED PARTS

The parts in this equipment have the specific characters of incombustibility and withstand voltage for safety. Therefore, the part which is replaced should be used the part which has the same character.

Especially as to the important parts for safety which is indicated in the circuit diagram or the table of parts as a  mark, the designated parts must be used.

3. PUT PARTS AND WIRES IN THE ORIGINAL POSITION AFTER ASSEMBLING OR WIRING

There are parts which use the insulation material such as a tube or tape for safety, or which are assembled in the condition that these do not contact with the printed board. The inside wiring is designed not to get closer to the pyrogenic parts and high voltage parts. Therefore, put these parts in the original positions.

4. PERFORM A SAFETY CHECK AFTER SERVICING

Confirm that the screws, parts and wiring which were removed in order to service are put in the original positions, or whether there are the portions which are deteriorated around the serviced places serviced or not. Check the insulation between the antenna terminal or external metal and the AC cord plug blades. And be sure the safety of that.

HOW TO ORDER PARTS

Please include the following informations when you order parts. (Particularly the VERSION LETTER.)

1. MODEL NUMBER and VERSION LETTER

You can find it in the back of your unit.

2. PART NO. and DESCRIPTION

You can find it in your SERVICE MANUAL.

CONTENTS

SERVICING NOTICES ON CHECKING	A1-1
HOW TO ORDER PARTS	A1-1
CONTENTS	A2-1
GENERAL SPECIFICATIONS	A3-1~A3-4
DISASSEMBLY INSTRUCTIONS	
1. REMOVAL OF MECHANICAL PARTS AND P. C. BOARDS	B1-1
2. REMOVAL OF DECK PARTS	B2-1~B2-6
3. REMOVAL AND INSTALLATION OF FLAT PACKAGE IC	B3-1, B3-2
KEY TO ABBREVIATIONS	C1-1, C1-2
SERVICE MODE LIST	C2-1
PREVENTIVE CHECKS AND SERVICE INTERVALS	C3-1
SERVICING FIXTURES AND TOOLS	C4-1
PREPARATION FOR SERVICING	C4-1
MECHANICAL ADJUSTMENTS	D1-1~D1-4
ELECTRICAL ADJUSTMENTS	D2-1, D2-2
BLOCK DIAGRAMS	
Y/C/AUDIO/CCD/HEAD AMP	E-1, E-2
SYSTEM CONTROL/SERVO	E-3, E-4
TUNER	E-5, E-6
HI-FI/DEMODULATOR	E-7, E-8
OPERATION/POWER	E-9, E-10
PRINTED CIRCUIT BOARDS	
SYSCON/OPERATION	F-1 ~ F-4
SCHEMATIC DIAGRAMS	
Y/C/AUDIO/CCD/HEAD AMP	G-1, G-2
SYSTEM CONTROL/SERVO	G-3, G-4
POWER	G-5, G-6
OPERATION	G-7, G-8
TUNER	G-9, G-10
HI-FI/DEMODULATOR	G-11, G-12
INTERCONNECTION DIAGRAM	G-13, G-14
WAVEFORMS	H-1
MECHANICAL EXPLODED VIEW	I-1
CHASSIS EXPLODED VIEWS	I-2, I-3
MECHANICAL REPLACEMENT PARTS LIST	J1-1
CHASSIS REPLACEMENT PARTS LIST	J2-1
ELECTRICAL REPLACEMENT PARTS LIST	J3-1

GENERAL SPECIFICATIONS

G-1	VCR System	System	VHS Player / Recorder				
		Video System	NTSC				
		Hi-Fi STEREO	Yes				
		NTSC PB(PAL60Hz)	No				
		Deck	DECK Loading System Motor	OVD-7 Front 3			
		Heads	Video Head	4Head			
			FM Audio Head	2Head			
			Normal Audio /Control	Mono / Yes			
			Erase(Full Track Erase)	Yes			
		Tape Speed	Rec	PAL NTSC	- SP/SLP		
			Play	PAL NTSC	- SP/LP/SLP		
		Fast Forward / Rewind Time (Approx.)		FF:4'50"/REW:2'30"			
			with Cassette	T-120			
		Forward/Reverse	NTSC or PAL-M	SP/LP/SLP=3x,5x/7x,9x/9x,15x			
		Picture Search	PAL or SECAM	-			
		Frame Advance	Slow	1/10			
		Slow Speed	Variable Slow	1/10			
G-2	Tuning System	Broadcasting System	US System M				
		Tuner and Receive CH	System Destination Tuning System Input Impedance CH Coverage	1Tuner USA(w/CATV) F-Synth VHF/UHF 75 OHM 2-69,4A,A-5~ A-1,A-1,J~ W W+1-W+84			
		Intermediate Frequency	Picture(FP) Sound(FS) FP-FS	45.75MHz 41.25MHz 4.50MHz			
		Preset CH		No			
		RF Converter Output		Yes			
			Channel	3 or 4 ch			
			Level/Impedance	66dBu /75ohm			
			Sound Selector	No			
		Stereo/Dual TV Sound		Yes			
		G-3	Power	Power Source	AC DC	120V,60Hz -	
				Power Consumption	Power On(at AC) Stand by (at AC) Per Year	9W at 120V 60Hz 1.8W at 120V 60Hz - kWh/Year	
				Protector	Power Fuse Dew Sensor	Yes No	
				G-4	Signal	Video Signal	Input Level Output Level S/N Ratio (Weighted) Horizontal Resolution at SP Mode
Audio Signal (0dB=0.775Vrms)	Input Level Output Level S/N Ratio at SP (Weighted) Harmonic Distortion (1KHz) Frequency Response at SP at LP at SLP					-8dB/50Kohm -8dB/1Kohm 42dB 1.5% 100Hz - 10kHz 100Hz - 6kHz 100Hz - 4kHz	
Hi-Fi Audio Signal	Dynamic Range : More than Frequency Response Wow And Flutter : Less than Channel Separation : More than Harmonic Distortion : Less than	90dB 20Hz ~20kHz 0.01 %Wrms 60 dB 0.01					
G-5	Interface	Switch	Front			Power Play Pause/Still System Select One Touch Playback Channel Up Channel Down F.FWD/Cue Eject/Stop Main Power SW Volume Up Volume Down Rew/Rev Rec/OTR	Yes Yes Yes Yes Yes Yes Yes Yes Yes
			Rear			RF Output SW	Yes
					No		
					No		
					No		
					No		
					No		
					No		
					No		
					No		

GENERAL SPECIFICATIONS

	Indicator	Power	Yes		
		Stand by	No		
		Rec/OTR	No		
		Repeat	No		
		TV/VCR	Yes		
		Rec	Yes		
		T-Rec	Yes		
		Tape In	No		
		Terminals	Front	Video Input	RCA x 1
				Audio Input	RCA x 2 (Stereo)
		Other Terminal		No	
		Rear	Video Input	No	
			Audio Input	No	
			Video Output	RCA x 1	
			Audio Output	RCA x 2 (Stereo)	
Euro Scart	No				
DC Jack 12V(Center +)	No				
VHF/UHF Antenna Input	F Type				
AC Inlet	No				
G-6	Set Size	Approx. W x D x H (mm)	360 x 229 x 95		
G-7	Weight	Net (Approx.)	3.2kg(7.1lbs)		
		Gross (Approx.)	3.8kg(8.4lbs)		
G-8	Regulation	Safety	UL		
		Radiation	FCC		
G-9	Temperature	Operation	5oC - 40oC		
		Storage	-20oC - 60oC		
G-10	Operating Humidity		Less then 80% RH		
G-11	On Screen Display	Menu	Yes		
		Menu Type	Character		
		ATS	No		
		Timer Rec Set	Yes		
		Auto Repeat On/Off	Yes		
		SAP On Off	Yes		
		CH Set-Up	TV/CATV	Yes	
			Auto CH Memory	Yes	
			Add/Delete	Yes	
		Pin Code Registration	No		
		System Set-Up	No		
		Clock Set	Yes (Calendar 12H)		
		Language	Yes		
		No Noise Back Ground	Yes		
		G-CODE(or SHOWVIEW or PLUSCODE)No. Entry	No		
		NICAM 1/2,NICAM Off,Audio Output	No		
		Stereo,Audio Output,SAP	Yes		
		Play/Stop/FF/Rew/Rec/OTR/T-Rec/Pause/Eject/Tape In (Symbol Mark)	Yes		
		CH/AV	Yes		
		Clock	Yes		
		Repeat	Yes		
		Pin Code	No		
		Tape Counter	Yes		
		Index	No		
		Hotel Lock	No		
		Tape Speed	Yes		
		Manual Tracking (Bar Setting)	No		
		Hi-Fi	Yes		
		S-Repeat/SR-R/SR-Play	No		
		VPS	No		
PDC	No				
G-12	OSD Language	OSD Language Setting	English French Spanish		
			English		
G-13	Display	Indicator	No		
		Indicator Type	-		
		Clock/Counter,CH,Timer Rec,OTR, Play Rec,FF(Cue),Rew(Rev),Stop,ATR	-		
		Pause("Rec"Flash)	-		
		Still("Play"Flush)	-		
		Eject(Tape Mark Flash)	-		
		Slow	-		
		WKL,Y.M.D,Start,End	-		
		AFT	-		
		Repeat	-		
		A-DUB	-		
		VCR	-		
		Memory	-		
		Index	-		
		VPS	-		
PDC	-				

GENERAL SPECIFICATIONS

		SP	-	
		LP	-	
		SLP	-	
		AM	-	
		PM	-	
		F1,F2	-	
		RF Output CH	-	
G-14	Clock,Timer and Timer Back-up	Calendar	1990/1/1 ~ 2081/12/31	
		Timer Events	8 prog/1 month	
		One Touch Recording Max Time	5 Hours	
		OTPB Valid Time	No	
		Timer Back-up (at Power Off Mode)	5 sec.	
G-15	Remote Control	Unit	RC-EA	
		Glow in Dark Remocon	No	
		Power Source	Voltage(D.C) UM size x pcs	3V UM-4 x 2 pcs
		Total Keys	33 Keys	
		Keys	Power	Yes
			1	Yes
			2	Yes
			3	Yes
			4	Yes
			5	Yes
			6	Yes
			7	Yes
			8	Yes
			9	Yes
		0	Yes	
		CH Up	Yes	
		CH Down	Yes	
		Input Select	Yes	
		Play	Yes	
		F.Fwd	Yes	
		Rew	Yes	
		Pause/Still	Yes	
		Stop	Yes	
		Rec/OTR	Yes	
		Eject	No	
		Counter Reset	Yes	
		Speed	Yes	
		Timer Rec	Yes	
		TV Monitor	No	
		Quick View	No	
		Program	No	
		Slow	Yes	
		Auto Tracking	Yes	
		Set/Tracking+	Yes	
		Set/ Tracking -	Yes	
		Menu	Yes	
		Enter	Yes	
		Cancel	Yes	
		Call	Yes	
		TV/VCR	Yes	
Sleep Timer	No			
Muting	No			
Clock/Counter	No			
Zero Return	No			
CM Skip	No			
Audio Select	Yes			
G-16	Features	Auto Head Cleaning	Yes	
		Auto Tracking	Yes	
		Index Search	No	
		HQ (VHS Standard High Quality)	Yes	
		Auto Power On, Auto Play, Auto Rewind, Auto Eject	Yes	
		Auto Power Off	Yes	
		Forward/Reverse Picture Search	Yes	
		VIDEO PLUS+(SHOWVIEW,G-CODE)	No	
		ATS	No	
		PDC	No	
		VPS	No	
		One Touch Playback	No	
		Picture Control	No	
		Auto Preset	No	
		Channel Lock	No	
		Hotel Lock	No	
		Anti Theft	No	
		Audio Dubbing	No	

GENERAL SPECIFICATIONS

		Remort Control Code 1/2	No		
		SQPB	No		
		CATV	Yes		
		Energy Star	Yes		
		MTS(SAP)	Yes		
		CM Skip(30sec x 6 Times)	No		
G-17	Accessories	Owner's Manual Language w/Guarantee Card	English/Spanish		
		Remote Control Unit	Yes		
		Dew Cation Sheet	No		
		Video Cassette Tape	No		
		Battery	No		
			UM size x pcs	-	
			Safety Tip	No	
			Toll Free Insert Sheet	No	
			Quick Set-Up Sheet	No	
			Information Sheet (Buyer Supply)	No	
			75 Ohm Coaxial Cable	Yes(Single shield)	
			Rod Antenna	No	
				Poles Terminal	
			Loop Antenna	No	
				Terminal	
			U/V Mixer	No	
			DC Car Cord (Center+)	No	
			Guarantee Card	Yes	
			Warning Sheet	No	
			Circuit Diagram	No	
			Antenna Change Plug	No	
			Service Facility List	No	
			Important Safeguard	No	
			Dew/AHC Caution Sheet	No	
			AC Plug Adapter	No	
			Quick Set-up Sheet	No	
			AC Cord	No	
			AV Cord (2Pin-1Pin)	No	
			Registration Card	No	
			PTB Sheet	No	
			Tape Rewinder(Buyer Supply)	No	
	300 ohm to 75 ohm Antenna Adapter	No			
G-18	Carton	Master Carton	No		
			Content	-	
			Material	-	
			Dimensions W x D x H(mm)	-	
			Description of Origin	-	
			Gift Box	Yes	
				Material	Single/White
				Dimensions W x D x H(mm)	420x291x160
				Design	As Per BUYER 's
				Description of Origin	Yes
			Drop Test	Natural Dropping At	1Corner / 3Edges / 6Surfaces
		Height (cm)	80		
		Container Stuffing(40' container)	3136Sets		
G-19	Cabinet Material	Cabinet Front	PS 94V2 DECABROM		

DISASSEMBLY INSTRUCTIONS

1. REMOVAL OF MECHANICAL PARTS AND P.C. BOARDS

1-1: TOP CABINET, FRONT CABINET AND OPERATION PCB (Refer to Fig. 1-1)

1. Remove the 4 screws ①.
2. Remove the Top Cabinet in the direction of arrow (A).
3. Disconnect the following connector: (CP651).
4. Unlock the 7 supports ②.
5. Remove the Front Cabinet in the direction of arrow (B).
6. Remove the 4 screws ③ and remove the Operation PCB.

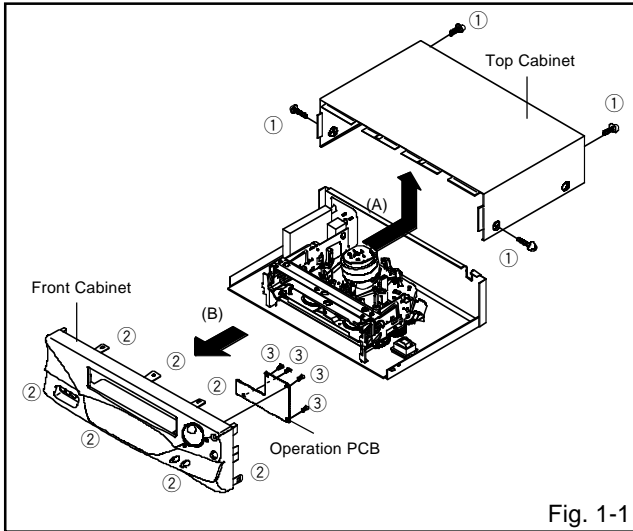

1-2: FLAP (Refer to Fig. 1-2)

1. Open Flap to 90° and flex in direction of arrow (A), at the same time slide in direction of arrow (B).
2. Then lift in direction of arrow (C).

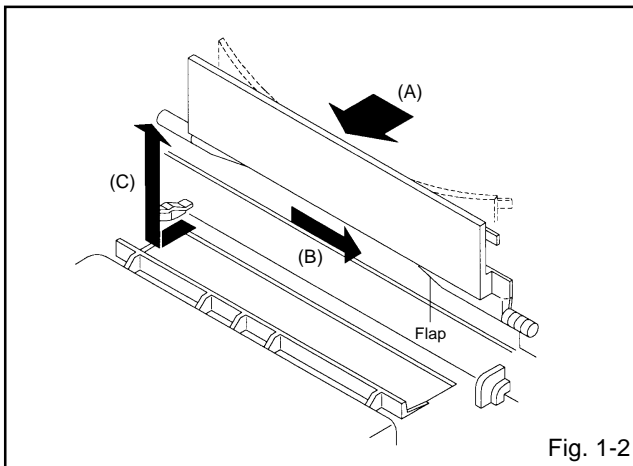

1-3: DECK CHASSIS (Refer to Fig. 1-3)

1. Remove the 3 screws ①.
2. Disconnect the following connectors: (CP1001, CP4001, CP4002 and CP4003).
3. Remove the Deck Chassis in the direction of arrow.

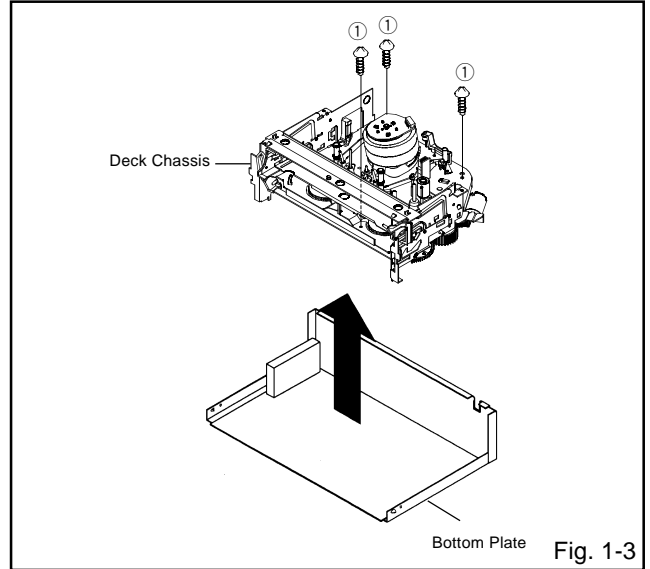

1-4: SYSCON PCB AND JACK PLATE (Refer to Fig. 1-4)

1. Remove the screw ①.
2. Remove the screw ②.
3. Remove the Syscon PCB in the direction of arrow.

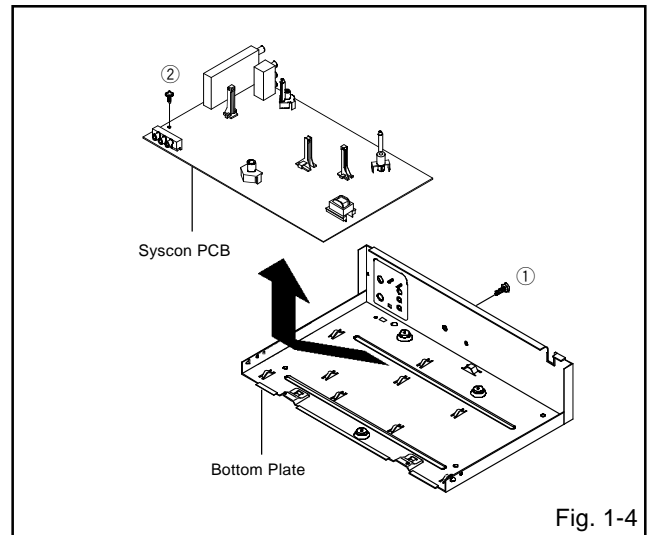

DISASSEMBLY INSTRUCTIONS

2. REMOVAL OF DECK PARTS

2-1: TOP BRACKET (Refer to Fig. 2-1)

1. Extend the 2 supports ①.
2. Slide the 2 supports ② and remove the Top Bracket.

NOTE

1. After the installation of the Top Bracket, bend the support ① so that the Top Bracket is fixed.

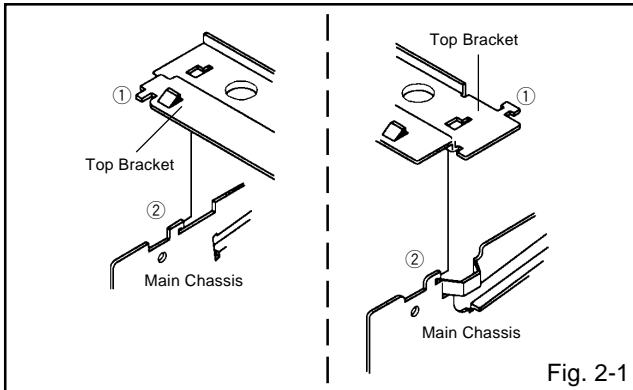

Fig. 2-1

2-2: CASSETTE HOLDER ASS'Y (Refer to Fig. 2-2)

1. Move the Cassette Holder Ass'y to the front side.
2. Push the Locker R to remove the Cassette Side R.
3. Remove the Cassette Side L.

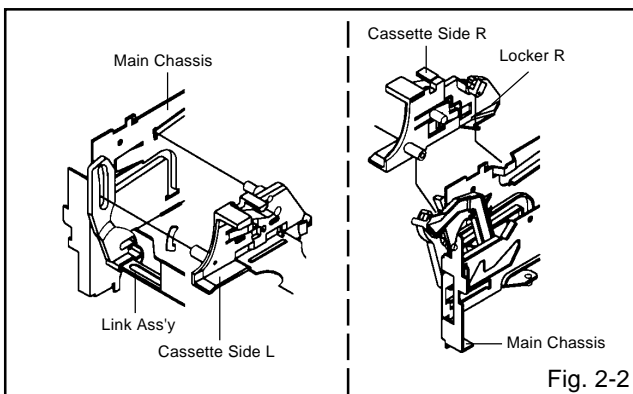

Fig. 2-2

2-3: CASSETTE SIDE L/R (Refer to Fig. 2-3-A)

1. Remove the Locker Spring.
2. Unlock the 4 supports ① and then remove the Cassette Side L/R.
3. Unlock the support ② and then remove the Locker R.

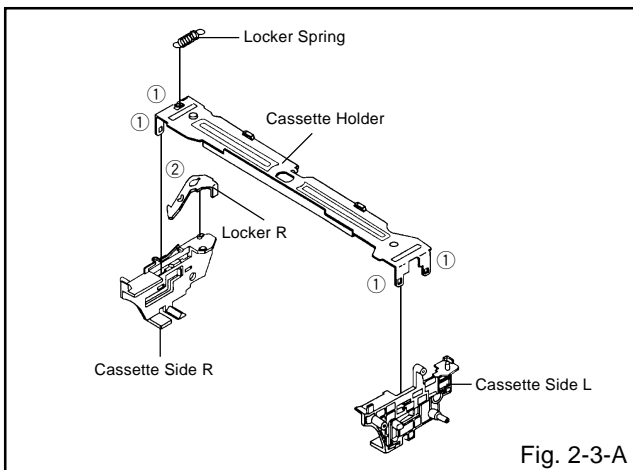

Fig. 2-3-A

NOTE

1. In case of the Locker R installation, check if the two positions of Fig.2-3-B are correctly locked.
2. When you install the Cassette Side R, be sure to move the Locker R after installing.

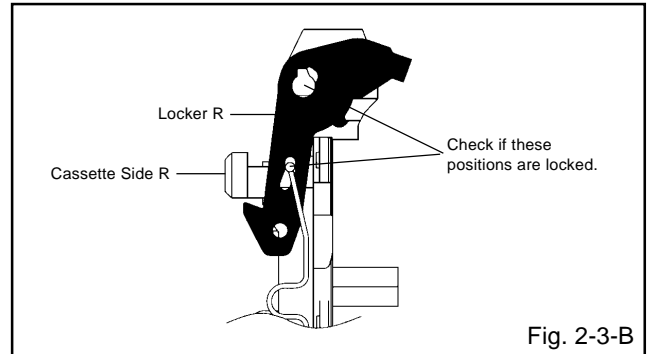

Fig. 2-3-B

2-4: LINK UNIT (Refer to Fig. 2-4)

1. Set the Link Unit to the Eject position.
2. Unlock the support ①.
3. Remove the (A) side of the Link Unit first, then remove the (B) side.

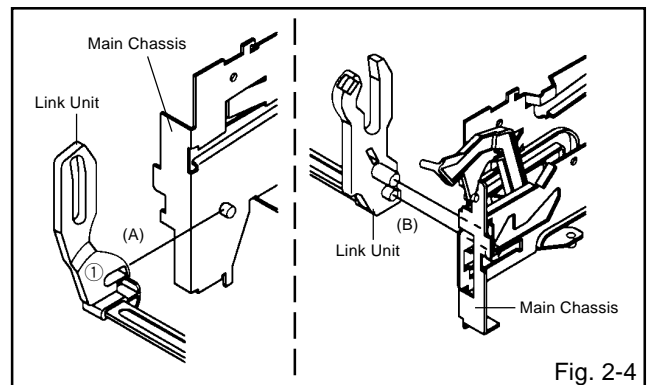

Fig. 2-4

2-5: LINK LEVER/FLAP LEVER (Refer to Fig. 2-5)

1. Remove the Link Lever.
2. Remove the Flap Lever.

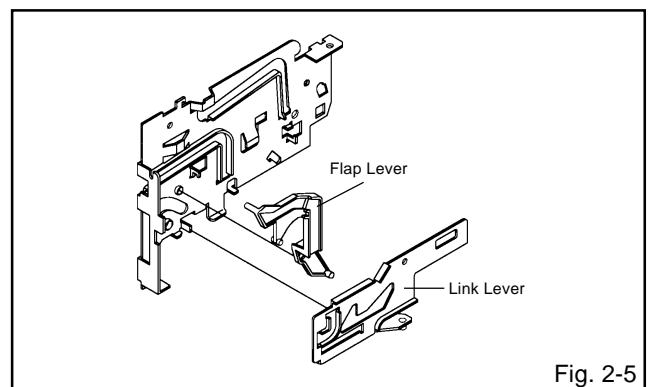
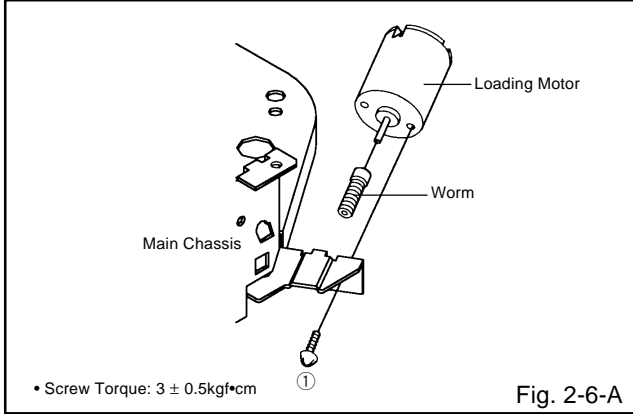

Fig. 2-5

DISASSEMBLY INSTRUCTIONS

2-6: LOADING MOTOR/WORM (Refer to Fig. 2-6-A)

1. Remove the screw ①.
2. Remove the Loading Motor.
3. Remove the Worm.



NOTE

1. In case of the Worm installation, check if the value of the Fig. 2-6-B is correct.

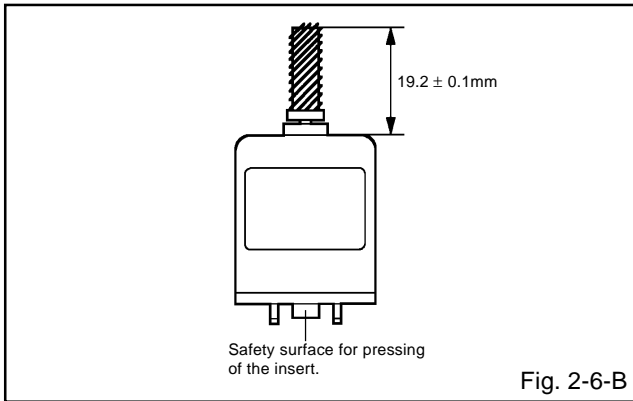

2-7: TENSION ASS'Y (Refer to Fig. 2-7-B)

1. Turn the Pinch Roller Cam clockwise so that the Tension Holder hook is set to the position of Fig. 2-7-A to move the Tension Arm Ass'y.
2. Remove the Tension Spring.
3. Unlock the 2 supports ① and remove the Tension Band.
4. Unlock the support ② and remove the Tension Arm Ass'y.
5. Unlock the support ③ and remove the Tension Connect.
6. Float the hook ④ and turn it clockwise then remove the Tension Holder.

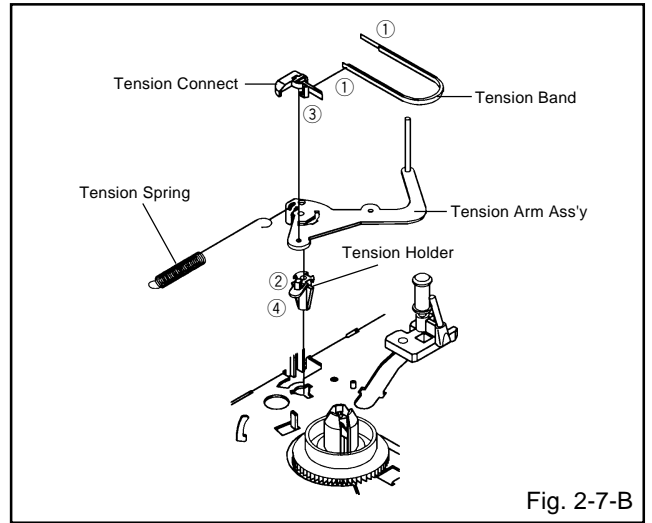
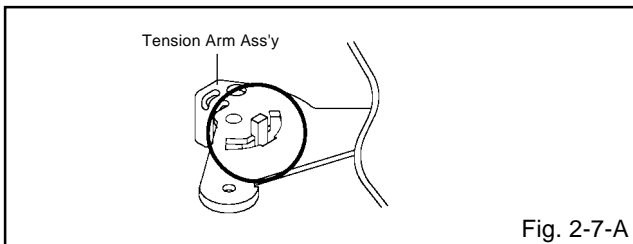

NOTE

1. In case of the Tension Band installation, note the direction of the installation. (Refer to Fig. 2-7-C)
2. In case of the Tension Band installation, install correctly as Fig. 2-7-D.
3. In case of the Tension Connect installation, install as the circled section of Fig. 2-7-E.

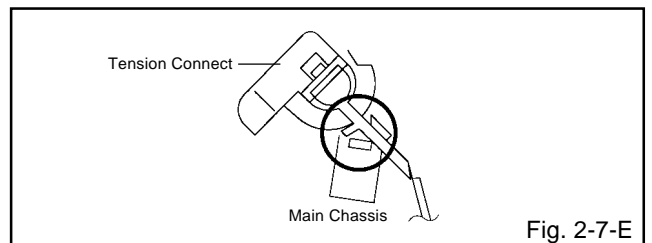
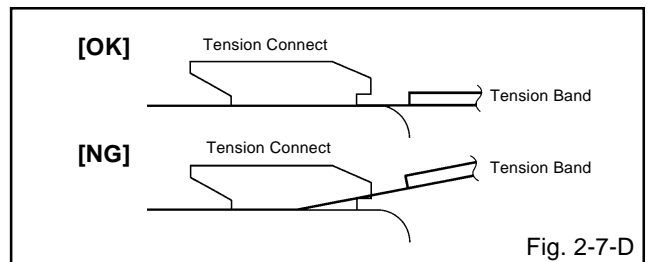
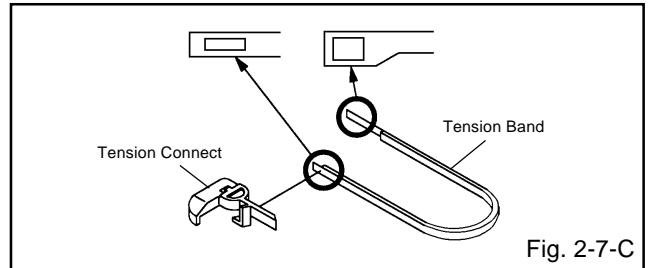

DISASSEMBLY INSTRUCTIONS

2-8: T BRAKE ARM/T BRAKE BAND (Refer to Fig. 2-8-A)

1. Remove the T Brake Spring.
2. Turn the T Brake Arm clockwise and bend the hook section to remove it.
3. Unlock the 2 supports ① and remove the T Brake Band.

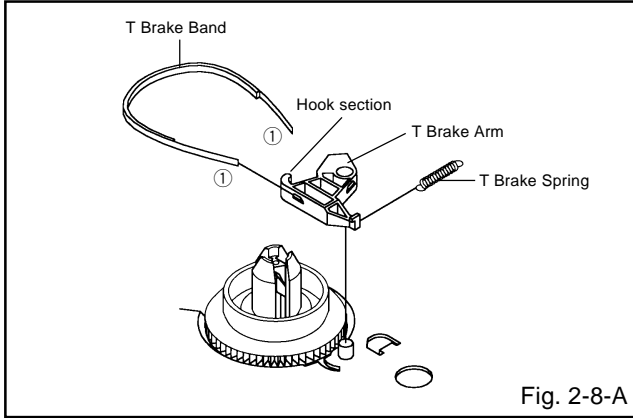

Fig. 2-8-A

NOTE

1. In case of the T Brake Band installation, install correctly as Fig. 2-8-B.

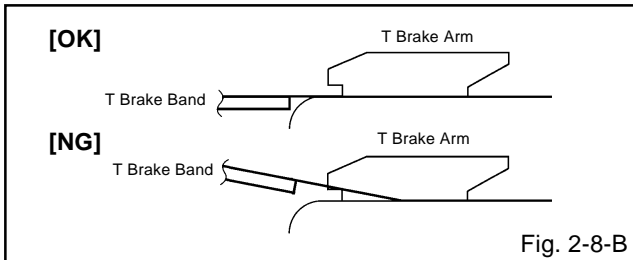

Fig. 2-8-B

2-9: S REEL/T REEL/IDLER ARM ASS'Y/IDLER GEAR (Refer to Fig. 2-9-A)

1. Remove the S Reel and T Reel.
2. Remove the 2 Polyslider Washers ①.
3. Remove the Idler Arm Ass'y and Idler Gear.

NOTE

1. Take care not to damage the gears of the S Reel and T Reel.
2. The Polyslider Washer may be remained on the back of the reel.
3. Take care not to damage the shaft.
4. Do not touch the section "A" of S Reel and T Reel. (Use gloves.) (Refer to Fig. 2-9-A) Do not adhere the stains on it.
5. When you install the reel, clean the shaft and grease it (MG-33). (If you do not grease, noise may be heard in FF/REW mode.)
6. After installing the reel, adjust the height of the reel. (Refer to MECHANICAL ADJUSTMENT)

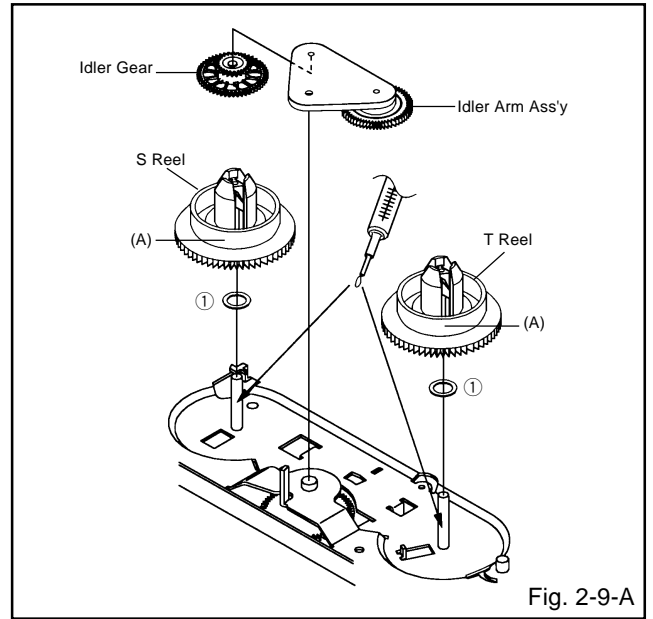

Fig. 2-9-A

NOTE

1. In case of the S Reel and T Reel installation, check if the correct parts are installed. (Refer to Fig. 2-9-B)
2. In case of the Idler Arm Ass'y installation, install correctly as Fig. 2-9-C.

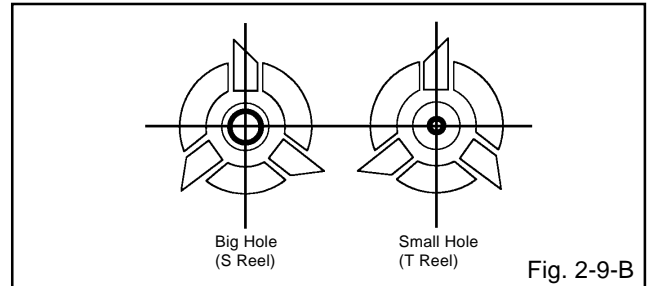

Fig. 2-9-B

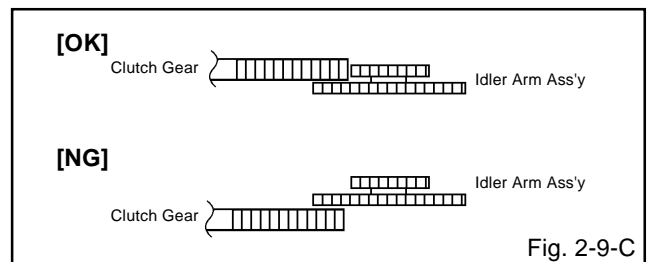
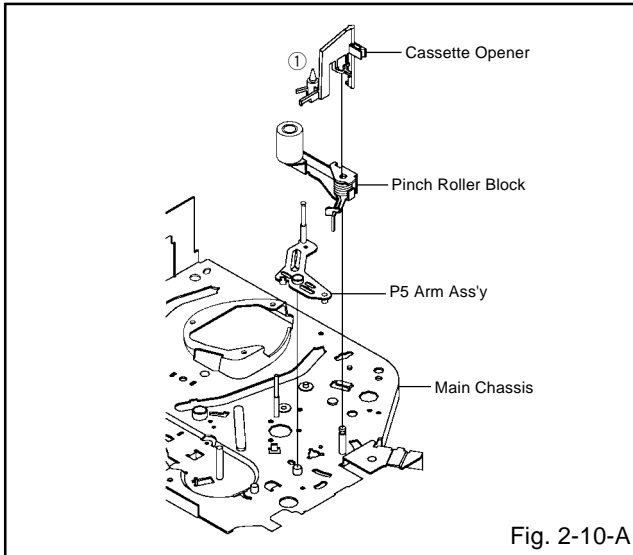

Fig. 2-9-C

DISASSEMBLY INSTRUCTIONS

2-10: CASSETTE OPENER/PINCH ROLLER BLOCK/ P5 ARM ASS'Y (Refer to Fig. 2-10-A)

1. Unlock the support ① and remove the Cassette Opener.
2. Remove the Pinch Roller Block and P5 Arm Ass'y.



NOTE

1. Do not touch the Pinch Roller. (Use gloves.)
2. In case of the Pinch Roller Block and the Pinch Roller Cam installation, install correctly as Fig. 2-10-B.

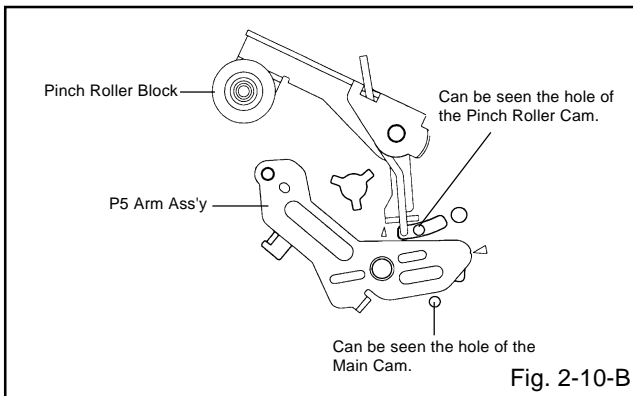

2-11: A/C HEAD (Refer to Fig. 2-11-A)

1. Remove the screw ①.
2. Remove the A/C Head Base.
3. Remove the 3 screws ②.
4. Remove the A/C Head and A/C Head Spring.

NOTE

1. Do not touch the A/C Head. (Use gloves.)
2. When you install the A/C Head Spring, install as shown in Fig. 2-11-B.
3. When you install the A/C Head, tighten the screw (1) first, then tighten the screw (2), finally tighten the screw (3).

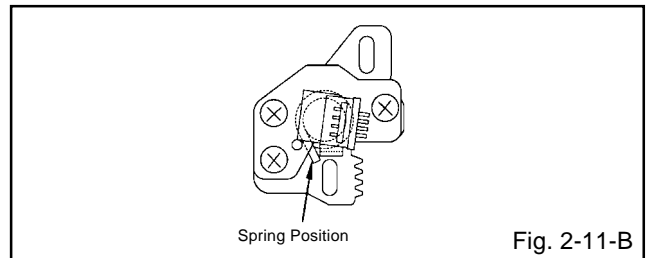
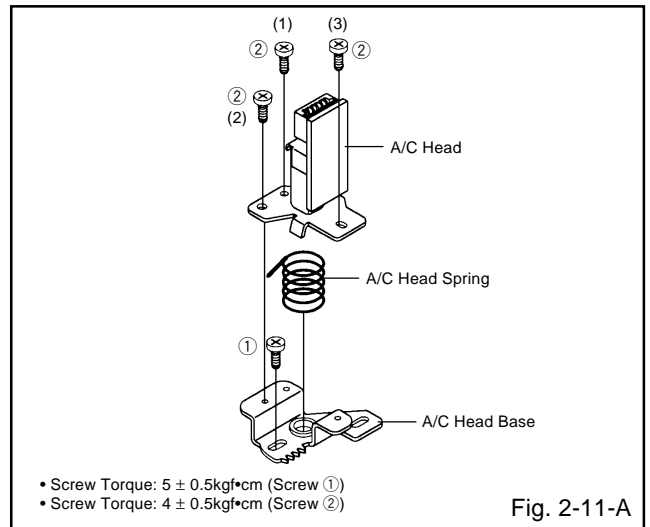

2-12: FE HEAD (RECORDER ONLY) (Refer to Fig. 2-12)

1. Remove the screw ①.
2. Remove the FE Head.

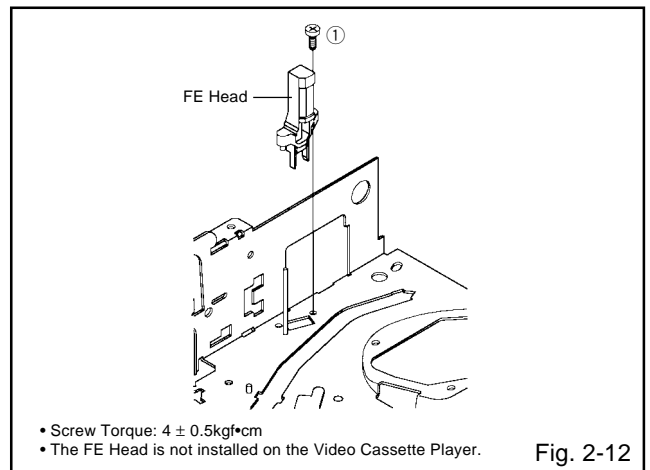

DISASSEMBLY INSTRUCTIONS

2-13: AHC ASS'Y/CYLINDER UNIT ASS'Y (Refer to Fig. 2-13)

1. Unlock the support ① and remove the AHC Ass'y.
2. Disconnect the following connector:
(CD2001)
3. Remove the 3 screws ②.
4. Remove the Cylinder Unit Ass'y.

NOTE

1. When you install the Cylinder Unit Ass'y, tighten the screws from (1) to (3) in order while pulling the Ass'y toward the left front direction.

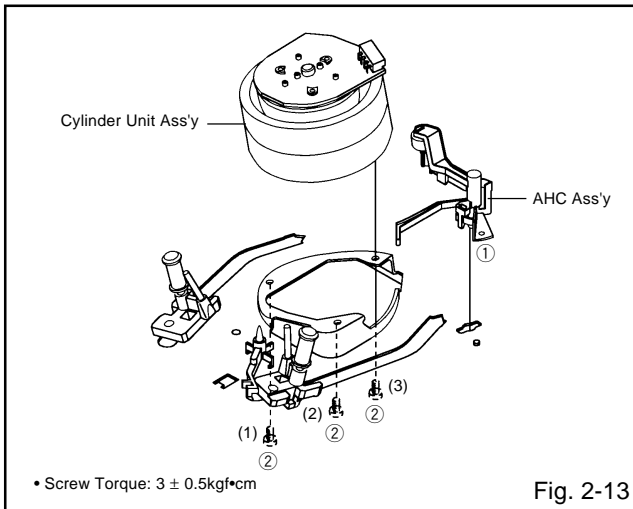

Fig. 2-13

2-14: CAPSTAN DD UNIT (Refer to Fig. 2-14)

1. Remove the Capstan Belt.
2. Remove the 3 screws ①.
3. Remove the Capstan DD Unit.

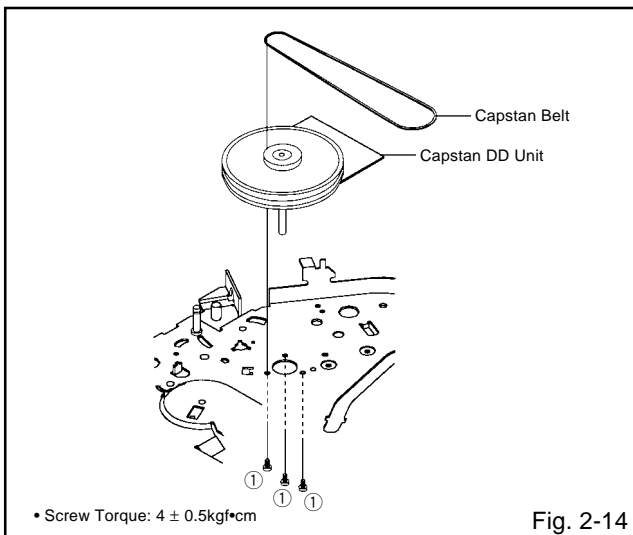
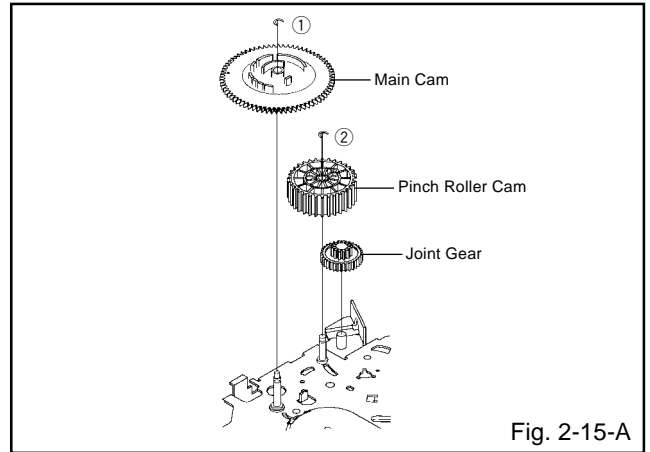

Fig. 2-14

2-15: MAIN CAM/PINCH ROLLER CAM/JOINT GEAR (Refer to Fig. 2-15-A)

1. Remove the E-Ring ①, then remove the Main Cam.
2. Remove the E-Ring ②, then remove the Pinch Roller Cam and Joint Gear.



NOTE

1. In case of the Pinch Roller Cam and Main Cam installation, install them as the circled section of Fig. 2-15-B so that the each markers are met. (Refer to Fig. 2-15-B)

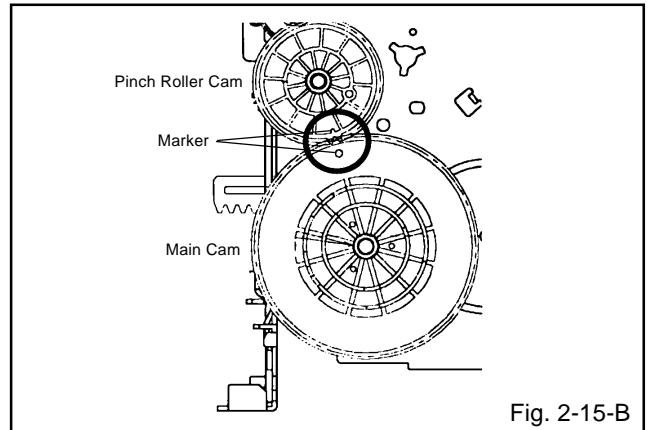

2-16: LOADING GEAR S/T ASS'Y (Refer to Fig. 2-16-A)

1. Remove the E-Ring ① and remove the Main Loading Gear.
2. Remove the Main Rod, Tension Lever, Loading Arm S Ass'y and Loading Arm T Ass'y.

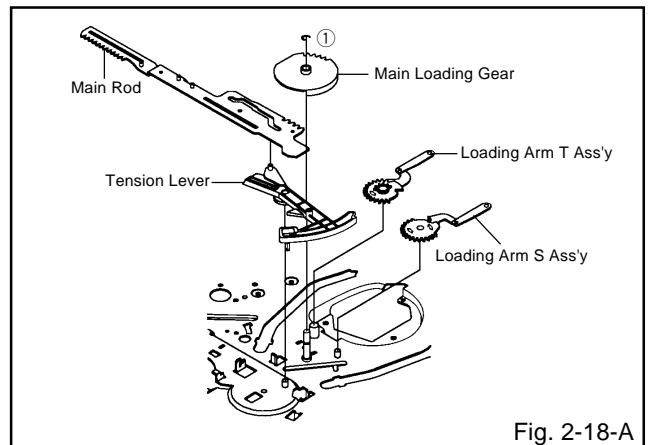

DISASSEMBLY INSTRUCTIONS

NOTE

1. When you install the Loading Arm S Ass'y, Loading Arm T Ass'y and Main Loading Gear, align each marker. (Refer to Fig. 2-16-B)

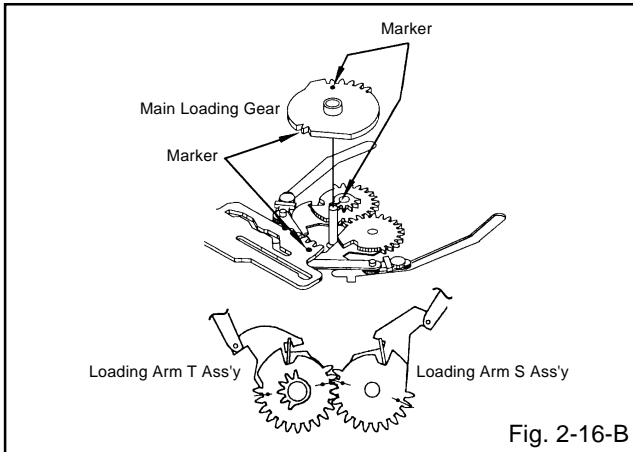

2-17: CLUTCH ASS'Y/RING SPRING/CLUTCH LEVER/CLUTCH GEAR (Refer to Fig. 2-17-A)

1. Remove the Polyslider Washer ①.
2. Remove the Clutch Ass'y and Ring Spring.
3. Remove the Clutch Lever.
4. Remove the Coupling Gear, Coupling Spring and Clutch Gear.

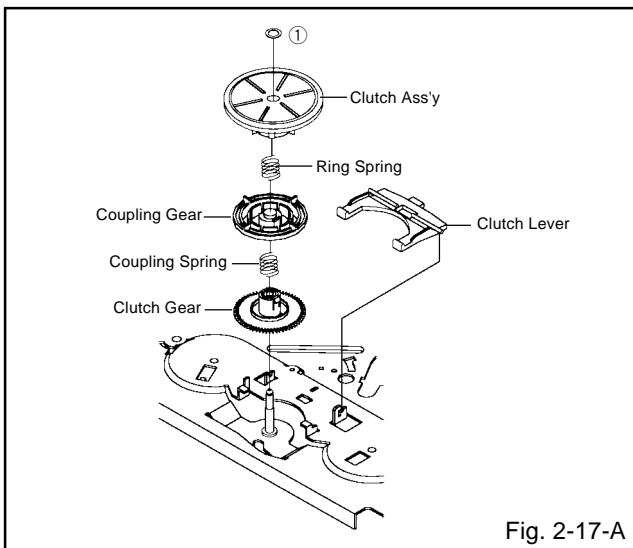

NOTE

1. In case of the Clutch Ass'y installation, install it with inserting the spring of the Clutch Ass'y into the dent of the Coupling Gear. (Refer to Fig. 2-17-B)

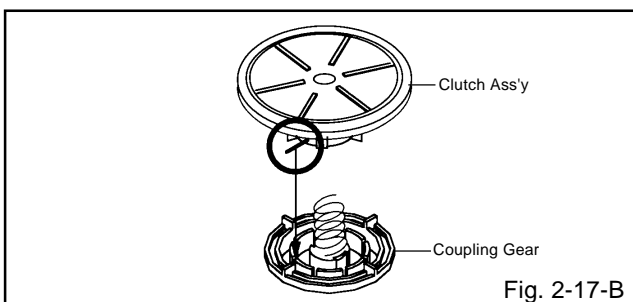

2-18: CASSETTE GUIDE POST/INCLINED BASE S/T UNIT/P4 CAP (Refer to Fig. 2-18-A)

1. Remove the P4 Cap.
2. Unlock the support ① and remove the Cassette Guide Post.
3. Remove the Inclined Base S Unit and Inclined Base T Unit.

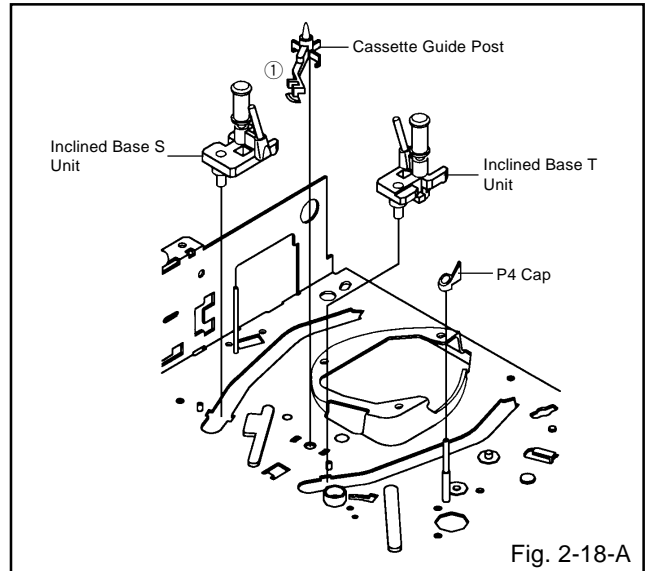

NOTE

1. Do not touch the roller of Guide Roller.
2. In case of the P4 Cap installation, install it with parallel for "A" and "B" of Fig. 2-18-B.
3. In case of the Cassette Guide Post installation, install correctly as the circled section of Fig. 2-18-C.

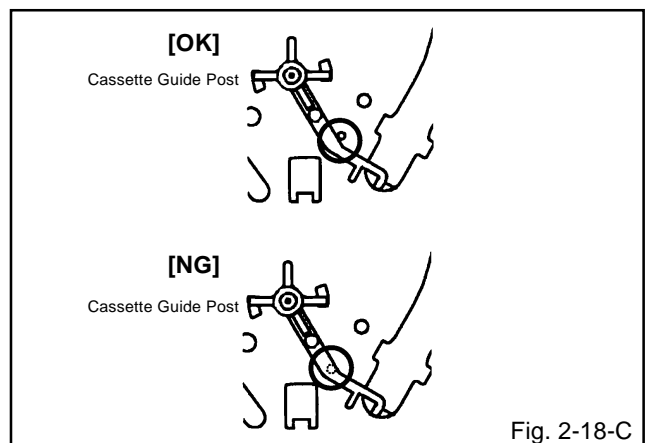
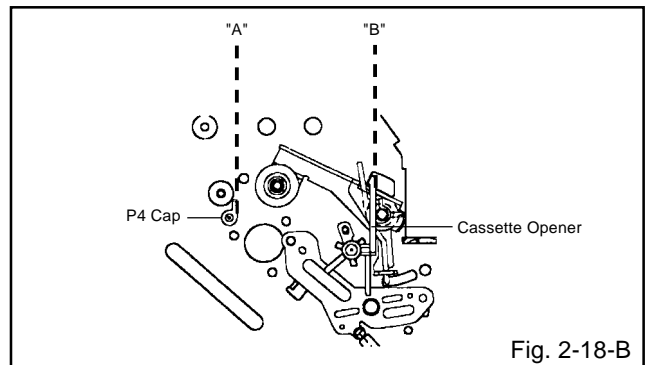

DISASSEMBLY INSTRUCTIONS

3. REMOVAL AND INSTALLATION OF FLAT PACKAGE IC

REMOVAL

1. Put the Masking Tape (cotton tape) around the Flat Package IC to protect other parts from any damage. (Refer to Fig. 3-1.)

NOTE

Masking is carried out on all the parts located within 10 mm distance from IC leads.

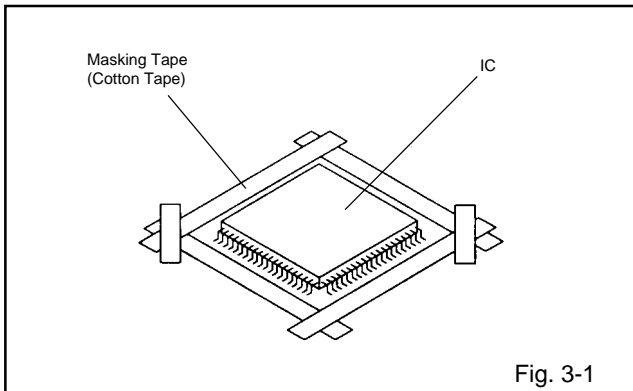

2. Heat the IC leads using a blower type IC desoldering machine. (Refer to Fig. 3-2.)

NOTE

Do not add the rotating and the back and forth directions force on the IC, until IC can move back and forth easily after desoldering the IC leads completely.

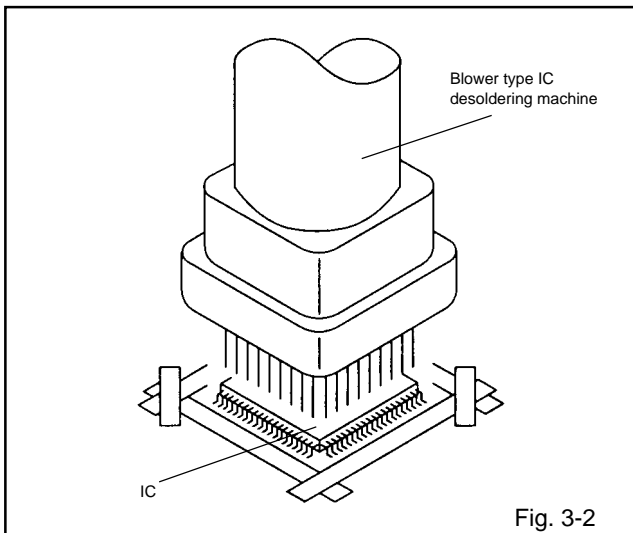

3. When IC starts moving back and forth easily after desoldering completely, pickup the corner of the IC using a tweezers and remove the IC by moving with the IC desoldering machine. (Refer to Fig. 3-3.)

NOTE

Some ICs on the PCB are affixed with glue, so be careful not to break or damage the foil of each IC leads or solder lands under the IC when removing it.

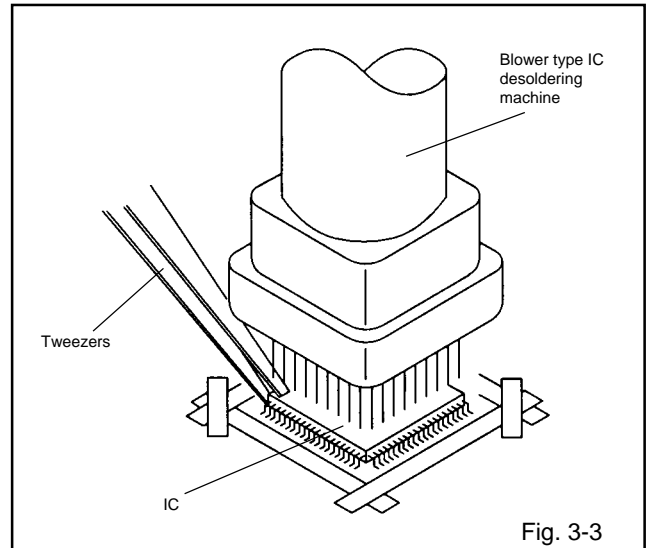

4. Peel off the Masking Tape.
5. Absorb the solder left on the pattern using the Braided Shield Wire. (Refer to Fig. 3-4.)

NOTE

Do not move the Braided Shield Wire in the vertical direction towards the IC pattern.

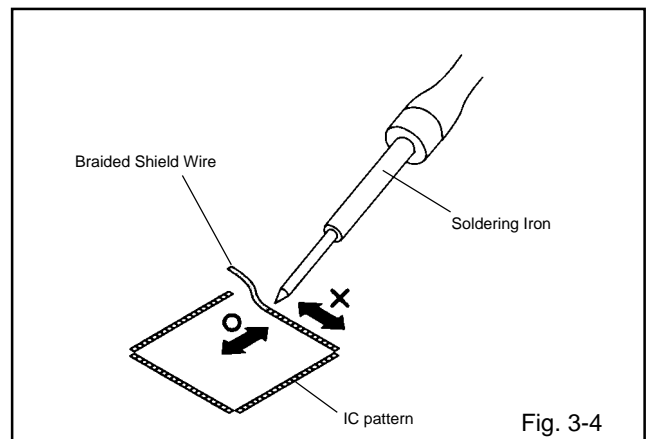

DISASSEMBLY INSTRUCTIONS

INSTALLATION

1. Take care of the polarity of new IC and then install the new IC fitting on the printed circuit pattern. Then solder each lead on the diagonal positions of IC temporarily. (Refer to Fig. 3-5.)

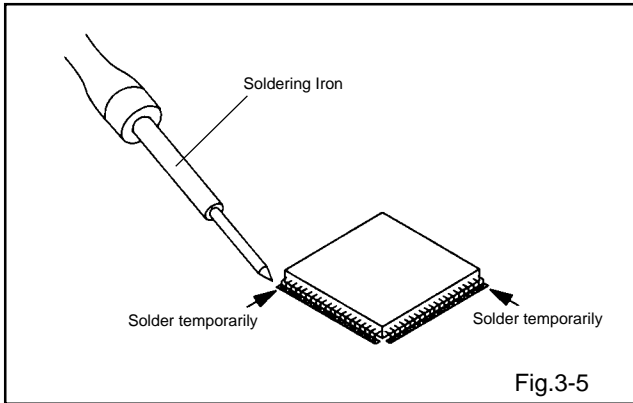

2. Supply the solder from the upper position of IC leads sliding to the lower position of the IC leads. (Refer to Fig. 3-6.)

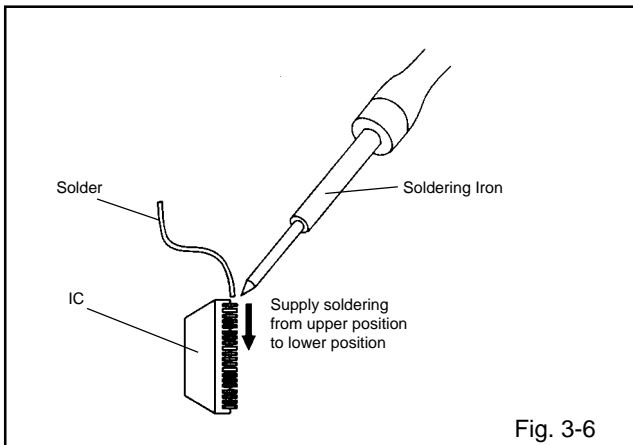

3. Absorb the solder left on the lead using the Braided Shield Wire. (Refer to Fig. 3-7.)

NOTE

Do not absorb the solder to excess.

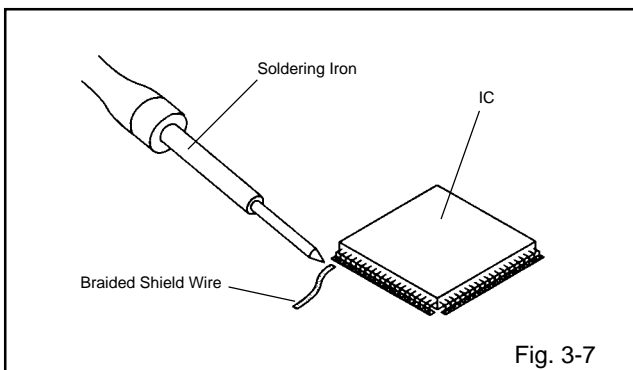

4. When bridge-soldering between terminals and/or the soldering amount are not enough, resolder using a Thin-tip Soldering Iron. (Refer to Fig. 3-8.)

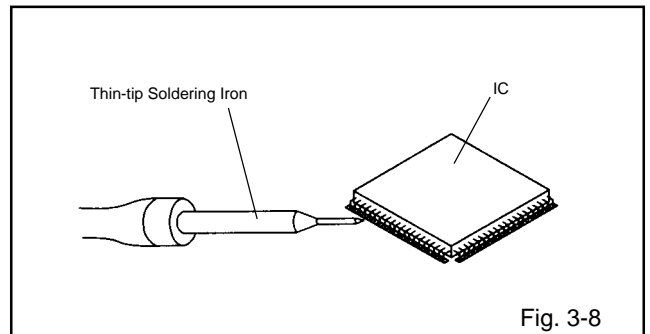

5. Finally, confirm the soldering status on four sides of the IC using a magnifying glass. Confirm that no abnormality is found on the soldering position and installation position of the parts around the IC. If some abnormality is found, correct by resoldering.

NOTE

When the IC leads are bent during soldering and/or repairing, do not repair the bending of leads. If the bending of leads are repaired, the pattern may be damaged. So, be always sure to replace the IC in this case.

KEY TO ABBREVIATIONS

A	A/C	: Audio/Control	H.SW	: Head Switch	
	ACC	: Automatic Color Control	Hz	: Hertz	
	AE	: Audio Erase	I	IC	: Integrated Circuit
	AFC	: Automatic Frequency Control		IF	: Intermediate Frequency
	AFT	: Automatic Fine Tuning		IND	: Indicator
	AFT DET	: Automatic Fine Tuning Detect		INV	: Inverter
	AGC	: Automatic Gain Control	K	KIL	: Killer
	AMP	: Amplifier	L	L	: Left
	ANT	: Antenna		LED	: Light Emitting Diode
	A.PB	: Audio Playback		LIMIT AMP	: Limiter Amplifier
	APC	: Automatic Phase Control		LM, LDM	: Loading Motor
	ASS'Y	: Assembly		LP	: Long Play
	AT	: All Time		L.P.F	: Low Pass Filter
	AUTO	: Automatic		LUMI.	: Luminance
	A/V	: Audio/Video	M	M	: Motor
B	BGP	: Burst Gate Pulse		MAX	: Maximum
	BOT	: Beginning of Tape		MINI	: Minimum
	BPF	: Bandpass Filter		MIX	: Mixer, mixing
	BRAKE SOL	: Brake Solenoid		MM	: Monostable Multivibrator
	BUFF	: Buffer		MOD	: Modulator, Modulation
	B/W	: Black and White		MPX	: Multiplexer, Multiplex
C	C	: Capacitance, Collector		MS SW	: Mecha State Switch
	CASE	: Cassette	N	NC	: Non Connection
	CAP	: Capstan		NR	: Noise Reduction
	CARR	: Carrier	O	OSC	: Oscillator
	CH	: Channel		OPE	: Operation
	CLK	: Clock	P	PB	: Playback
	CLOCK (SY-SE)	: Clock (Syscon to Servo)		PB CTL	: Playback Control
	COMB	: Combination, Comb Filter		PB-C	: Playback-Chrominance
	CONV	: Converter		PB-Y	: Playback-Luminance
	CPM	: Capstan Motor		PCB	: Printed Circuit Board
	CTL	: Control		P. CON	: Power Control
	CYL	: Cylinder		PD	: Phase Detector
	CYL-M	: Cylinder-Motor		PG	: Pulse Generator
	CYL SENS	: Cylinder-Sensor		P-P	: Peak-to Peak
D	DATA (SY-CE)	: Data (Syscon to Servo)	R	R	: Right
	dB	: Decibel		REC	: Recording
	DC	: Direct Current		REC-C	: Recording-Chrominance
	DD Unit	: Direct Drive Motor Unit		REC-Y	: Recording-Luminance
	DEMODO	: Demodulator		REEL BRK	: Reel Brake
	DET	: Detector		REEL S	: Reel Sensor
	DEV	: Deviation		REF	: Reference
E	E	: Emitter		REG	: Regulated, Regulator
	EF	: Emitter Follower		REW	: Rewind
	EMPH	: Emphasis		REV, RVS	: Reverse
	ENC	: Encoder		RF	: Radio Frequency
	ENV	: Envelope		RMC	: Remote Control
	EOT	: End of Tape		RY	: Relay
	EQ	: Equalizer	S	S. CLK	: Serial Clock
	EXT	: External		S. COM	: Sensor Common
F	F	: Fuse		S. DATA	: Serial Data
	FBC	: Feed Back Clamp		SEG	: Segment
	FE	: Full Erase		SEL	: Select, Selector
	FF	: Fast Forward, Flipflop		SENS	: Sensor
	FG	: Frequency Generator		SER	: Search Mode
	FL SW	: Front Loading Switch		SI	: Serial Input
	FM	: Frequency Modulation		SIF	: Sound Intermediate Frequency
	FSC	: Frequency Sub Carrier		SO	: Serial Output
	FWD	: Forward		SOL	: Solenoid
G	GEN	: Generator		SP	: Standard Play
	GND	: Ground		STB	: Serial Strobe
H	H.P.F	: High Pass Filter		SW	: Switch

KEY TO ABBREVIATIONS

S	SYNC	:	Synchronization
	SYNC SEP	:	Sync Separator, Separation
T	TR	:	Transistor
	TRAC	:	Tracking
	TRICK PB	:	Trick Playback
	TP	:	Test Point
U	UNREG	:	Unregulated
V	V	:	Volt
	VCO	:	Voltage Controlled Oscillator
	VIF	:	Video Intermediate Frequency
	VP	:	Vertical Pulse, Voltage Display
	V.PB	:	Video Playback
	VR	:	Variable Resistor
	V.REC	:	Video Recording
	VSF	:	Visual Search Fast Forward
	VSR	:	Visual Search Rewind
	VSS	:	Voltage Super Source
	V-SYNC	:	Vertical-Synchronization
	VT	:	Voltage Tuning
X	X'TAL	:	Crystal
Y	Y/C	:	Luminance/Chrominance

SERVICE MODE LIST

This unit provided with the following SERVICE MODES so you can repair, examine and adjust easily.

Method	Operations
Press the ATR button on the remote control for more than 2 seconds during PLAY.	Adjusting of the Tracking to the center position. Refer to the "MECHANICAL ADJUSTMENT" (GUIDE ROLLER) and "ELECTRICAL ADJUSTMENT" (PG SHIFTER).
Make the short circuit between the test point of SERVICE and the GND.	The EOT/BOT/Reel sensor do not work at this moment. Refer to the "PREPARATION FOR SERVICING"

PREVENTIVE CHECKS AND SERVICE INTERVALS

The following standard table depends on environmental conditions and usage. Unless maintenance is properly carried out, the following service intervals may be quite shortened as harmful effects may be had on other parts. Also, long term storage or misuse may cause transformation and aging of rubber parts.

Time Parts Name	500 hours	1,000 hours	1,500 hours	2,000 hours	3,000 hours	Notes
Audio Control Head	■	■	■	■	■	Clean those parts in contact with the tape.
Full Erase Head (Recorder only)	■	■	■	■	■	
Capstan Belt			■	■	●	Clean the rubber, and parts which the rubber touches.
Pinch Roller	■	■	■	■	■ ●	
Capstan DD Unit					●	
Loading Motor					●	
Tension Band					●	
Capstan Shaft	■	■	■	■	■	Replace when rolling becomes abnormal.
Tape Running Guide Post	■	■	■	■	■	
Cylinder Unit	■	■	■	■	●	Clean the Head

■ : Clean
● : Replace

CLEANING

NOTE

After cleaning the heads with isopropyl alcohol, do not run a tape until the heads dry completely. If the heads are not completely dry and alcohol gets on the tape, damage may occur.

1. AUDIO CONTROL HEAD

Clean the Audio Control Head with the cotton stick soaked by alcohol. Clean the full erase head in the same manner. (Refer to the figure below.)

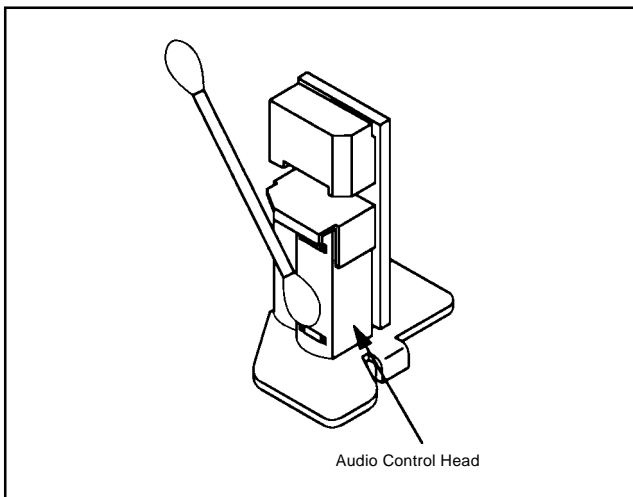

2. TAPE RUNNING SYSTEM

When cleaning the tape transport system, use the gauze moistened with isopropyl alcohol.

3. CYLINDER

Wrap a piece of chamois around your finger. Dip it in isopropyl alcohol. Hold it to the cylinder head softly. Turn the cylinder head counterclockwise to clean it (in the direction of the arrow). (Refer to the figure below.)

NOTE

Do not exert force against the cylinder head. Do not move the chamois upward or downward on the head. Use the chamois one by one.

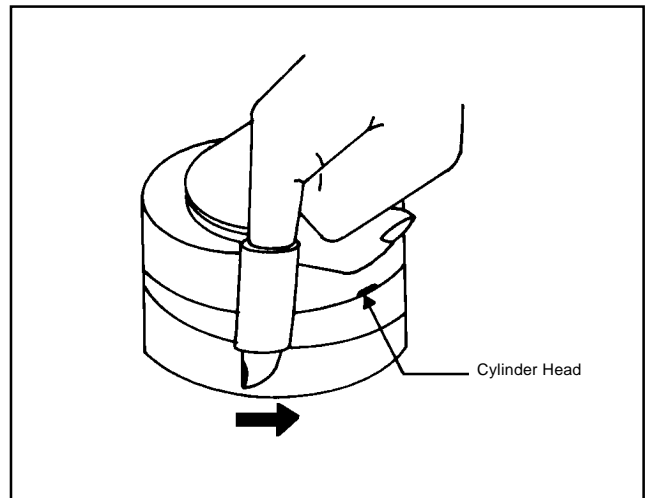

SERVICING FIXTURES AND TOOLS

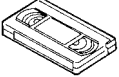
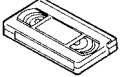
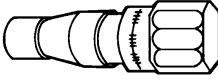
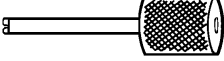
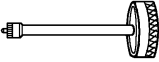
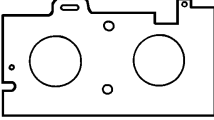
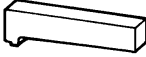
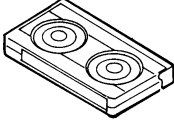
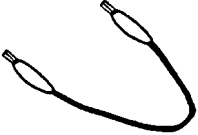
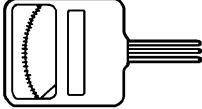
<p>(For 2 heads model) VHS Alignment Tape JG001 (VN₂S-LI6³) JG001A (VN₂S-CO1³) JG001Q (VN₂S-LI6³H) JG001T (VN₂S-X6³)</p> 	<p>(For 4 heads model) VHS Alignment Tape JG001B (VN₁S-LI6³) JG001I (VN₁S-CO1³) JG001P (VN₁S-LI6³H) JG001S (VN₁S-X6³)</p> 	<p>JG002B Adapter JG002E Dial Torque Gauge (10~90gf•cm) JG002F (60~600gf•cm)</p> 	<p>JG005 Post Adjustment Screwdriver Part No. SV-TG0-030-000 (small)</p> 
<p>JG153 X Value Adjustment Screwdriver</p> 	<p>JG022 Master Plane</p> 	<p>JG024A Reel Disk Height Adjustment Jig</p> 	<p>JG100A Torque Tape (VHT-063)</p> 
<p>JG154 Cable</p> 	<p>Tentelometer</p> 		

Ref. No.	Part No.	Parts Name	Remarks
JG001	APJG001000	VHS Alignment Tape (For 2 heads model)	Monoscope, 6KHz
JG001A	APJG001A00	VHS Alignment Tape (For 2 heads model)	Color Bar, 1KHz
JG001Q	APJG001Q00	VHS Alignment Tape (For 2 heads model)	Hi-Fi Audio
JG001T	APJG001T00	VHS Alignment Tape (For 2 heads model)	X Value Adjustment
JG001B	APJG001B00	VHS Alignment Tape (For 4 heads model)	Monoscope, 6KHz
JG001I	APJG001I00	VHS Alignment Tape (For 4 heads model)	Color Bar, 1KHz
JG001P	APJG001P00	VHS Alignment Tape (For 4 heads model)	Hi-Fi Audio
JG001S	APJG001S00	VHS Alignment Tape (For 4 heads model)	X Value Adjustment
JG002B	APJG002B00	Adapter	VSR Torque, Brake Torque (S Reel/T Reel Ass'y)
JG002E	APJG002E00	Dial Torque Gauge (10~90gf•cm)	Brake Torque (T Reel Ass'y)
JG002F	APJG002F00	Dial Torque Gauge (60~600gf•cm)	VSR Torque, Brake Torque (S Reel)
JG005	APJG005000	Post Adjustment Screwdriver	Guide Roller Adjustment
JG153	APJG153000	X Value Adjustment Screwdriver	X Value Adjustment
JG022	APJG022000	Master Plane	Reel Disk Height Adjustment
JG024A	APJG024A00	Reel Disk Height Adjustment Jig	Reel Disk Height Adjustment
JG100A	APJG100A00	Torque Tape (VHT-063)	Playback Torque, Back Tension Torque During Playback
JG154	APJG154000	Cable	Used to connect the test point of SERVICE and GROUND

PREPARATION FOR SERVICING

- Short circuit between **TP1001** and **Ground** with the cable JG154.
(Refer to MAJOR COMPONENTS LOCATION GUIDE)
The EOT, BOT and Reel Sensor do not work at this moment.
At that time, the STOP/EJECT button is available to insert and eject the Cassette Tape.

MECHANICAL ADJUSTMENTS

1. CONFIRMATION AND ADJUSTMENT

Read the following NOTES before starting work.

- Place an object which weighs between 450g~500g on the Cassette Tape to keep it steady when you want to make the tape run without the Cassette Holder. (Do not place an object which weighs over 500g.)
- When you activate the deck without the Cassette Holder, short circuit between **TP1001** and **GND**. (Refer to **ELECTRICAL ADJUSTMENT PARTS LOCATION GUIDE**) In this condition the BOT/EOT/Reel Sensor will not function.

1-1: CONFIRMATION AND ADJUSTMENT OF REEL DISK HEIGHT

1. Turn on the power and set to the STOP mode.
2. Set the master plane (**JG022**) and reel disk height adjustment jig (**JG024A**) on the mechanism framework, taking care not to scratch the drum, as shown in **Fig. 1-1-A**.
3. While turning the reel and confirm the following points. Check if the surface "A" of reel disk is lower than the surface "B" of reel disk height adjustment jig (**JG024A**) and is higher than the surface "C". If it is not passed, place the height adjustment washers and adjust to 10(+2, -0)mm.
4. Adjust the other reel in the same way.

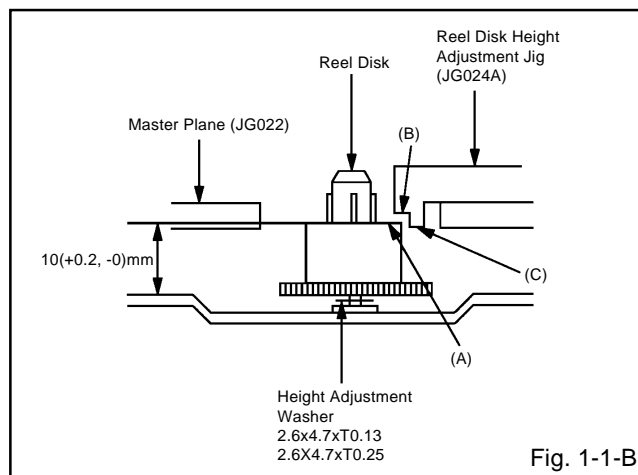
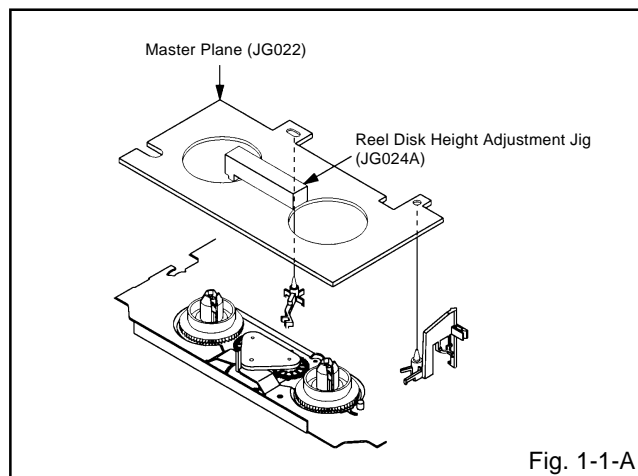

1-2: CONFIRMATION AND ADJUSTMENT OF TENSION POST POSITION

1. Set to the PLAY mode.
2. Adjust the adjusting parts for the Tension Arm position so that the Tension Arm top is within the standard line of Main Chassis.
3. While turning the S Reel clockwise, confirm that the edge of the Tension Arm is located in the position described above.

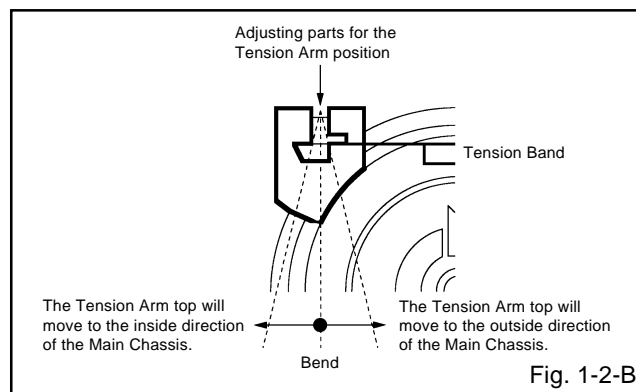
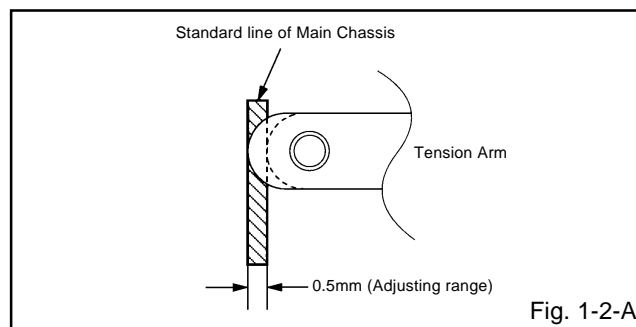

1-3: CONFIRMATION OF PLAYBACK TORQUE AND BACK TENSION TORQUE DURING PLAYBACK

1. Load a video tape (T-120) recorded in standard speed mode. Set the unit to the PLAY mode.
2. Install the tentelometer as shown in **Fig. 1-3**. Confirm that the meter indicates $20 \pm 2\text{gf}$ in the beginning of playback.

• USING A CASSETTE TYPE TORQUE TAPE (**JG100A**)

1. After confirmation and adjustment of Tension Post position (Refer to item 1-2), load the cassette type torque tape (**JG100A**) and set to the PLAY mode.
2. Confirm that the right meter of the torque tape indicates 50~90gf•cm during playback in SP mode.
3. Confirm that the left meter of the torque tape indicates 25~40gf•cm during playback in SP mode.

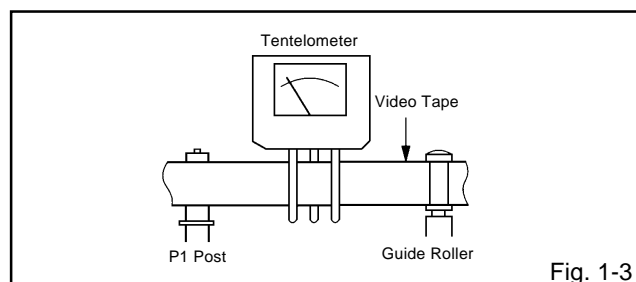

MECHANICAL ADJUSTMENTS

1-4: CONFIRMATION OF VSR TORQUE

1. Install the Torque Gauge (JG002F) and Adapter (JG002B) on the S Reel. Set to the Picture Search (Rewind) mode. (Refer to Fig.1-4-B)
2. Then, confirm that it indicates 120~180gf•cm.

NOTE

Install the Torque Gauge on the reel disk firmly. Press the REW button to turn the reel disk.

1-5: CONFIRMATION OF REEL BRAKE TORQUE

(S Reel Brake) (Refer to Fig.1-4-B)

1. Once set to the Fast Forward mode then set to the Stop mode. While, unplug the AC cord when the Pinch Roller Block is on the position of Fig. 1-4-A.
2. Move the Idler Ass'y from the S Reel.
3. Install the Torque Gauge (JG002F) and Adapter (JG002B) on the S Reel. Turn the Torque Gauge (JG002F) clockwise.
4. Then, confirm that it indicates 60~100gf•cm.

(T Reel Brake) (Refer to Fig. 1-4-B)

1. Once set to the Fast Forward mode then set to the Stop mode. While, unplug the AC cord when the Pinch Roller Block is on the position of Fig. 1-4-A.
2. Move the Idler Ass'y from the T Reel.
3. Install the Torque Gauge (JG002E) and Adapter (JG002B) on the T reel. Turn the Torque Gauge (JG002E) counterclockwise.
4. Then, confirm that it indicates 30~50gf•cm.

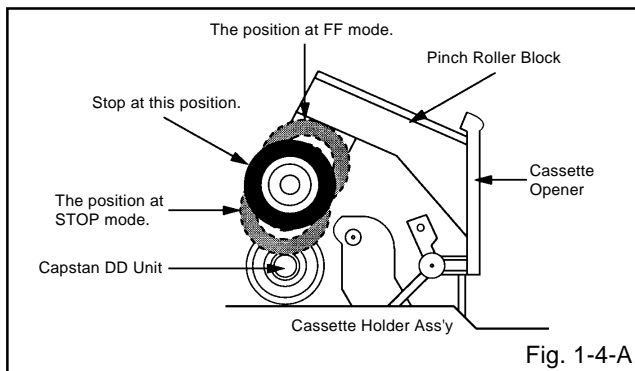

Fig. 1-4-A

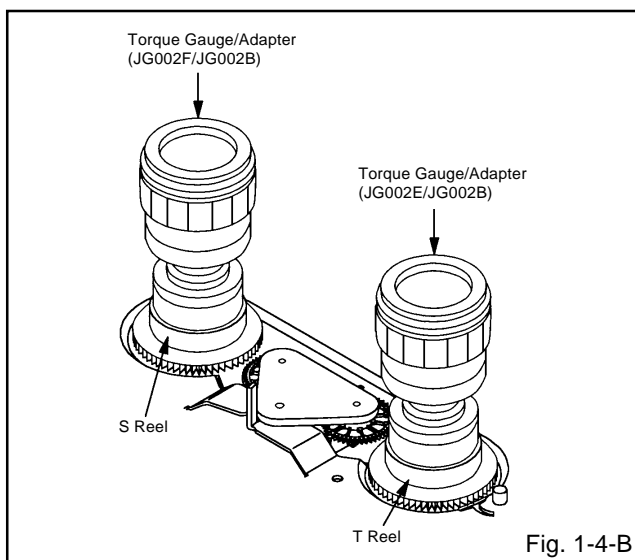

Fig. 1-4-B

NOTE

If the torque is out of the range, replace the following parts.

Check item	Replacement Part
1-4	Idler Ass'y/Clutch Ass'y
1-5	S Reel side: S Reel/Tension Band/Tension Connect/Tension Arm Ass'y T Reel side: T Reel/T Brake Band//T Brake Spring/T Brake Arm

2. CONFIRMATION AND ADJUSTMENT OF TAPE RUNNING MECHANISM

Tape Running Mechanism is adjusted precisely at the factory. Adjustment is not necessary as usual. When you replace the parts of the tape running mechanism because of long term usage or failure, the confirmation and adjustment are necessary.

2-1: GUIDE ROLLER

1. Playback the VHS Alignment Tape (JG001 or JG001B). (Refer to SERVICING FIXTURE AND TOOLS)
2. Connect CH-1 of the oscilloscope to TP4001 (Envelope) and CH-2 to TP1002 (SW Pulse).
3. Press and hold the Tracking-Auto button on the remote control more than 2 seconds to set tracking to center.
4. Trigger with SW Pulse and observe the envelope. (Refer to Fig. 2-1-A)
5. When observing the envelope, adjust the Adjusting Driver (JG005) slightly until the envelope will be flat. Even if you press the Tracking Button, adjust so that flatness is not moved so much.
6. Adjust so that the A : B ratio is better than 3 : 2 as shown in Fig. 2-1-B, even if you press the Tracking Button to move the envelope (The envelope waveform will begin to decrease when you press the Tracking Button).
7. Adjust the PG shifter during playback. (Refer to the ELECTRICAL ADJUSTMENTS)

NOTE

After adjustment, confirm and adjust A/C head. (Refer to item 2-2)

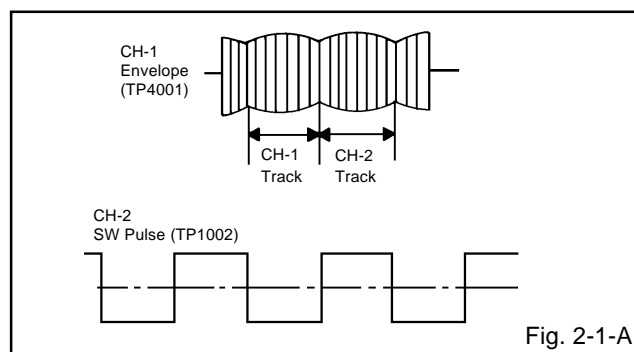

Fig. 2-1-A

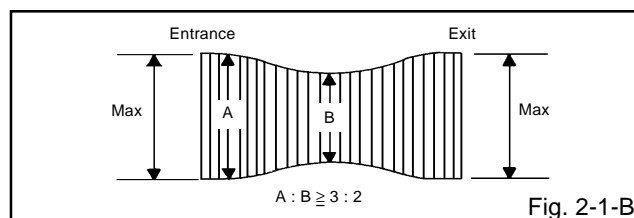

Fig. 2-1-B

MECHANICAL ADJUSTMENTS

2-2: CONFIRMATION AND ADJUSTMENT OF AUDIO/CONTROL HEAD

When the Tape Running Mechanism does not work well, adjust the following items.

1. Playback the VHS Alignment Tape (**JG001** or **JG001B**) .
(Refer to **SERVICING FIXTURE AND TOOLS**)
2. Confirm that the reflected picture of stamp mark is appeared on the tape prior to P4 Post as shown in **Fig. 2-2-A**.
 - a) When the reflected picture is distorted, turn the screw ① clockwise until the distortion is disappeared.
 - b) When the reflected picture is not distorted, turn the screw ① counterclockwise until little distortion is appeared, then adjust the a).
3. Turn the screw ② to set the audio level to maximum.
4. Confirm that the bottom of the Audio/ Control Head and the bottom of the tape is shown in **Fig. 2-2-C**.
 - a) When the height is not correct, turn the screw ③ to adjust the height. Then, adjust the 1~3 again.

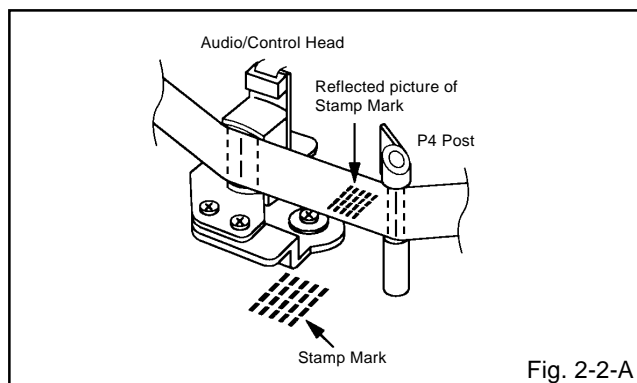

Fig. 2-2-A

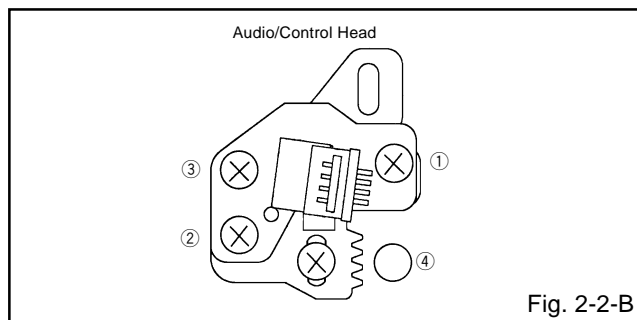

Fig. 2-2-B

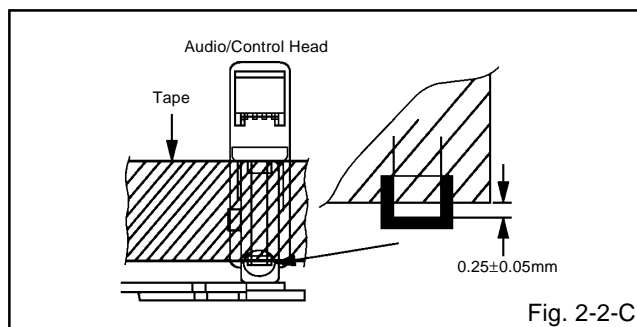

Fig. 2-2-C

2-3: TAPE RUNNING ADJUSTMENT (X VALUE ADJUSTMENT)

1. Confirm and adjust the height of the Reel Disk.
(Refer to item 1-1)
2. Confirm and adjust the position of the Tension Post.
(Refer to item 1-2)
3. Adjust the Guide Roller. (Refer to item 2-1)
4. Confirm and adjust the Audio/Control Head.
(Refer to item 2-2)
5. Connect CH-1 of the oscilloscope to **TP4001**, CH-2 to **TP1002** and CH-3 to **HOT side of Audio Out Jack**.
6. Playback the VHS Alignment Tape (**JG001S** or **JG001T**). (Refer to **SERVICING FIXTURE AND TOOLS**)
7. Press and hold the Tracking-Auto button on the remote control more than 2 seconds to set tracking to center.
8. Set the X Value adjustment driver (**JG153**) to the ④ of **Fig. 2-2-B**. Adjust X value so that the envelope waveform output becomes maximum. Check if the relation between Audio and Envelope waveform becomes (1) or (2) of **Fig. 2-3**.

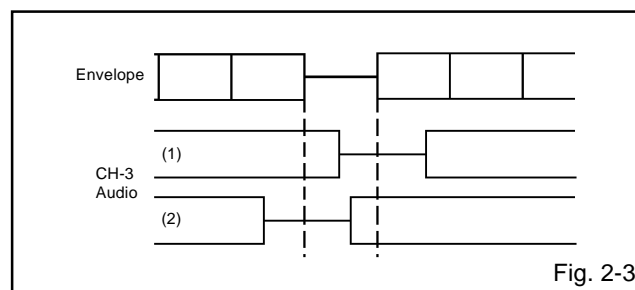

Fig. 2-3

2-4: CONFIRM HI-FI AUDIO (Hi-Fi model only)

1. Connect CH-1 of the oscilloscope to **TP1002** and CH-2 to the **Hi-Fi Audio Out Jack**.
2. Playback the VHS Alignment Tape (**JG001P** or **JG001Q**).
(Refer to **SERVICING FIXTURE AND TOOLS**)
3. Press and hold the Tracking-Auto button on the remote control more than 2 seconds to set tracking to center.
4. Press the Tracking Up button and count number of steps which the audio output is changed from Hi-Fi (10KHz) to MONO (6KHz).
5. Press and hold the Tracking-Auto button on the remote control more than 2 seconds to set tracking to center.
6. Press the Tracking Down button and count number of steps which the audio output is changed from Hi-Fi (10KHz) to MONO (6KHz).
7. If the difference are more than 3 steps, set the X Value adjustment driver (**JG153**) to ④ of **Fig. 2-2-B**. Change the X Value and adjust it so that the value becomes within 2 steps.

MECHANICAL ADJUSTMENTS

3. MECHANISM ADJUSTMENT PARTS LOCATION GUIDE

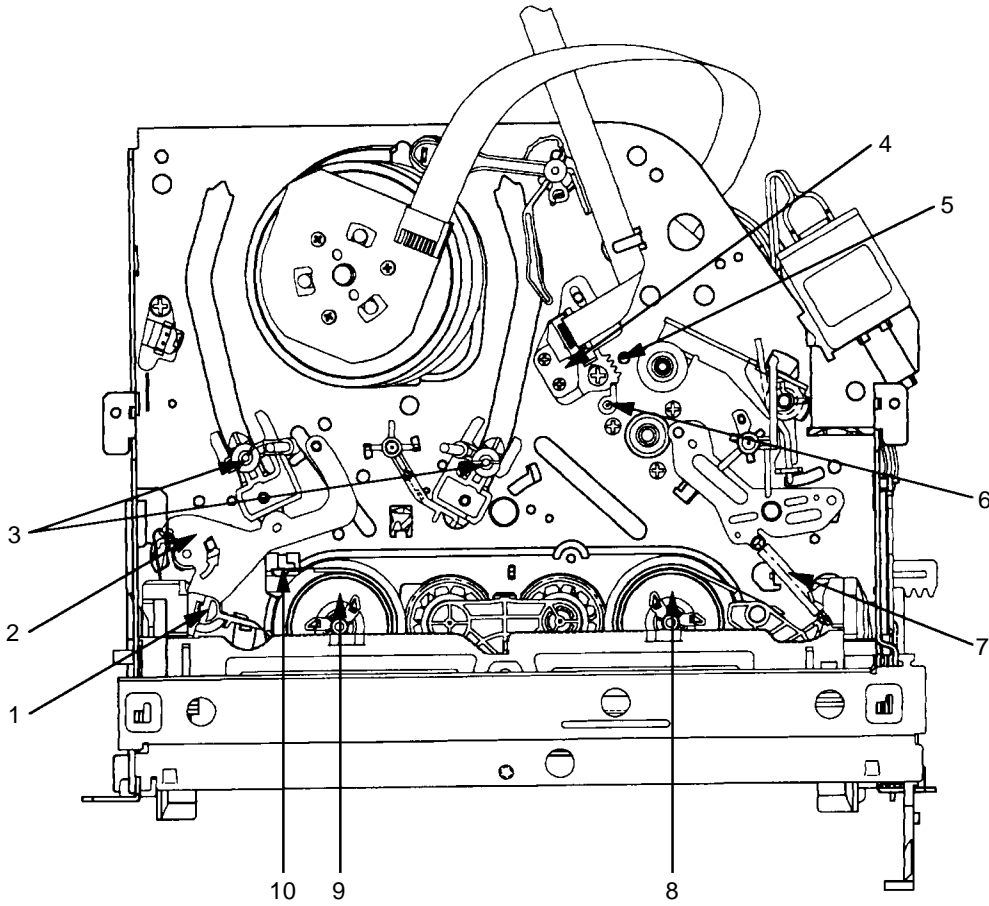

- | | |
|-----------------------------------|--|
| 1. Tension Connect | 6. P4 Post |
| 2. Tension Arm | 7. T Brake Spring |
| 3. Guide Roller | 8. T Reel |
| 4. Audio/Control Head | 9. S Reel |
| 5. X value adjustment driver hole | 10. Adjusting parts for the Tension Arm position |

ELECTRICAL ADJUSTMENTS

Read and perform this adjustment when repairing the circuits or replacing electrical parts or PCB assemblies.

1. BASIC ADJUSTMENT

CAUTION

When replacing IC's or transistors, use only specified silicon grease (**YG6260M**).
(To prevent the damage to IC's and transistors.)

1-1: PG SHIFTER

CONDITIONS

MODE-PLAYBACK
Input Signal-Alignment Tape (**JG001P**)

INSTRUCTIONS

1. Connect CH-1 on the oscilloscope to **TP1002** and CH-2 to **TP4201**.
2. Playback the alignment tape. (**JG001P**)
3. Press and hold the Tracking-Auto button on the remote control more than 2 seconds to set tracking to center.
4. Adjust the **VR1001** until the waveform of the oscilloscope measures $6.5 \pm 0.5(H)$ at both leading and trailing edges. (Refer to Fig. 1-1-A, B)

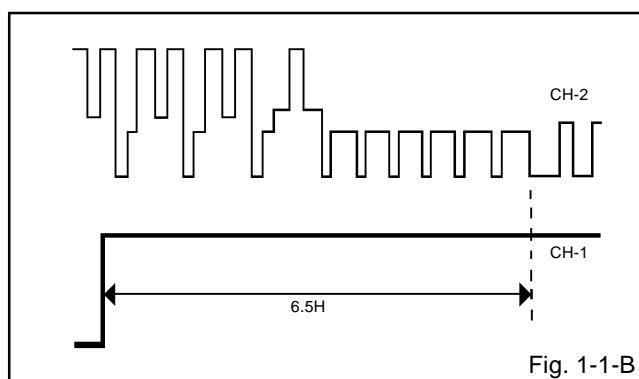
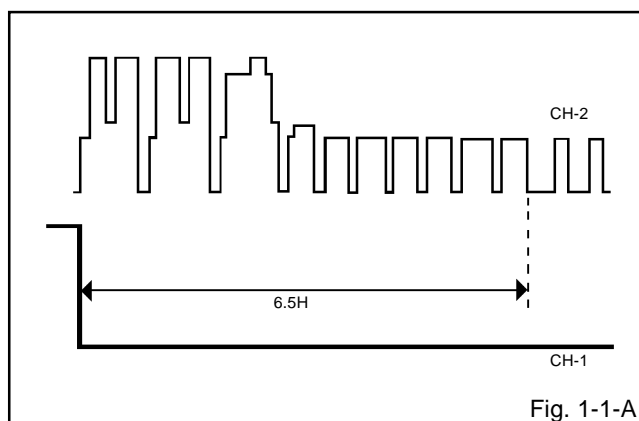

ELECTRICAL ADJUSTMENTS

2. ELECTRICAL ADJUSTMENT PARTS LOCATION GUIDE

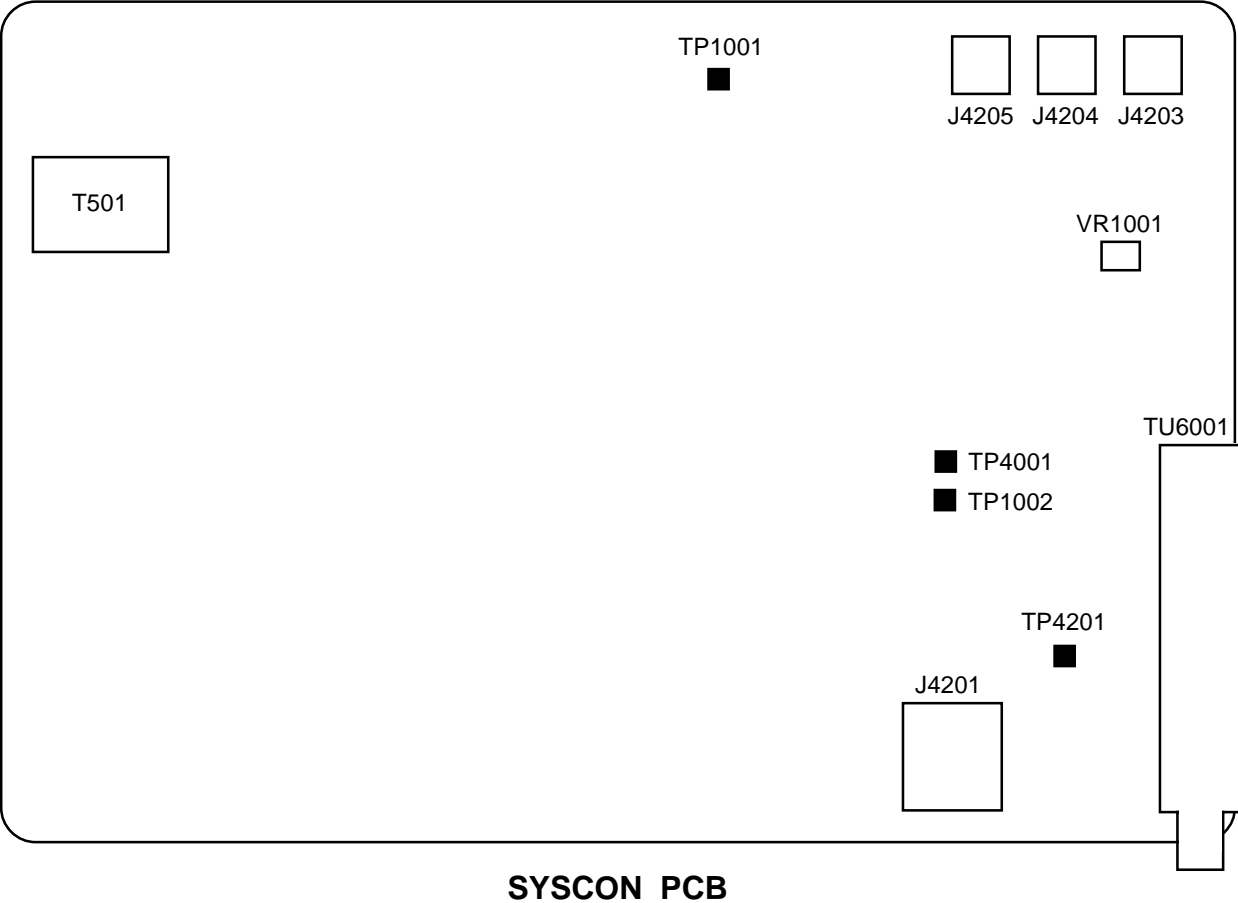

Y/C/AUDIO/CCD/HEAD AMP BLOCK DIAGRAM

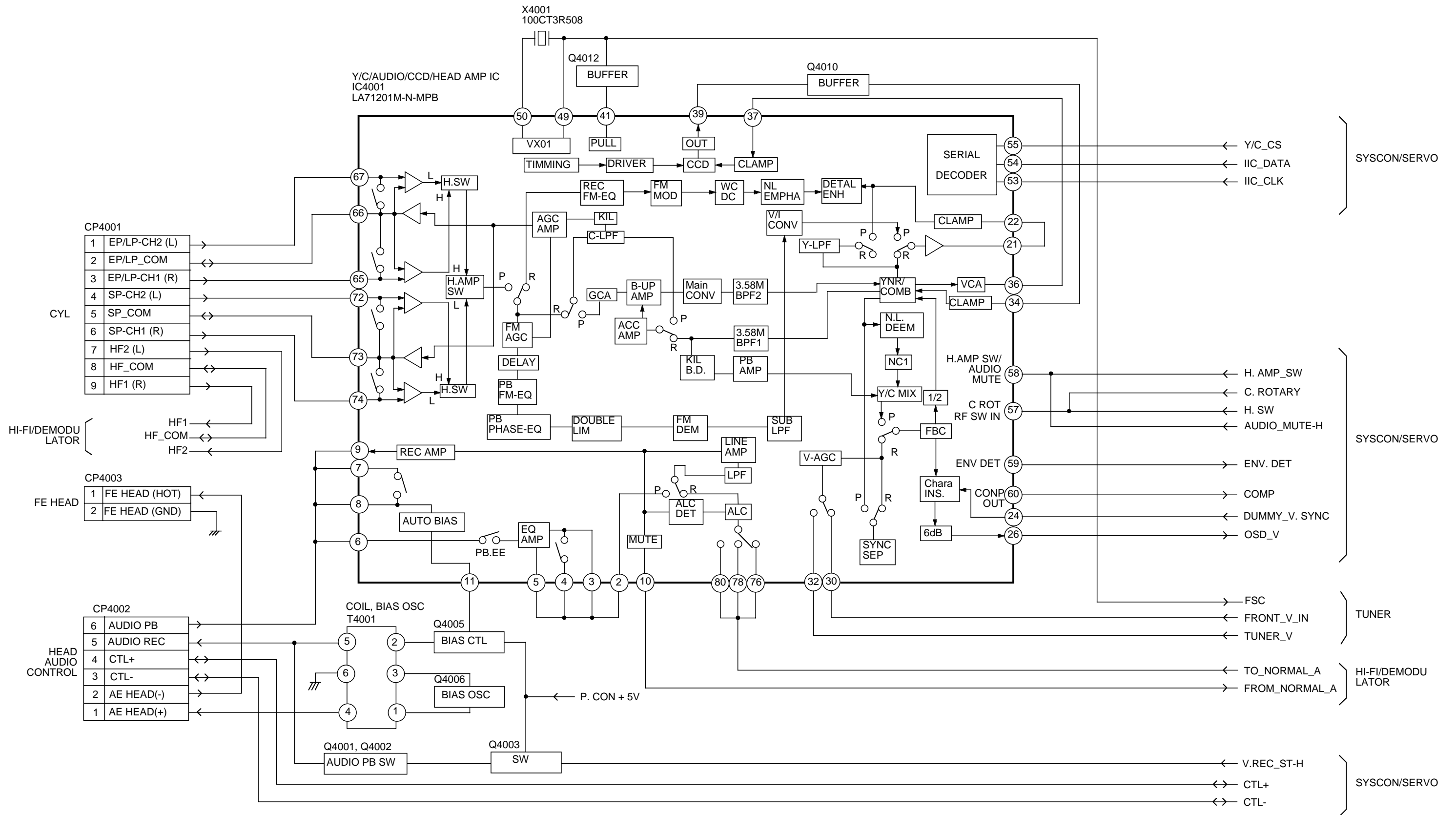

SYSTEM CONTROL/SERVO BLOCK DIAGRAM

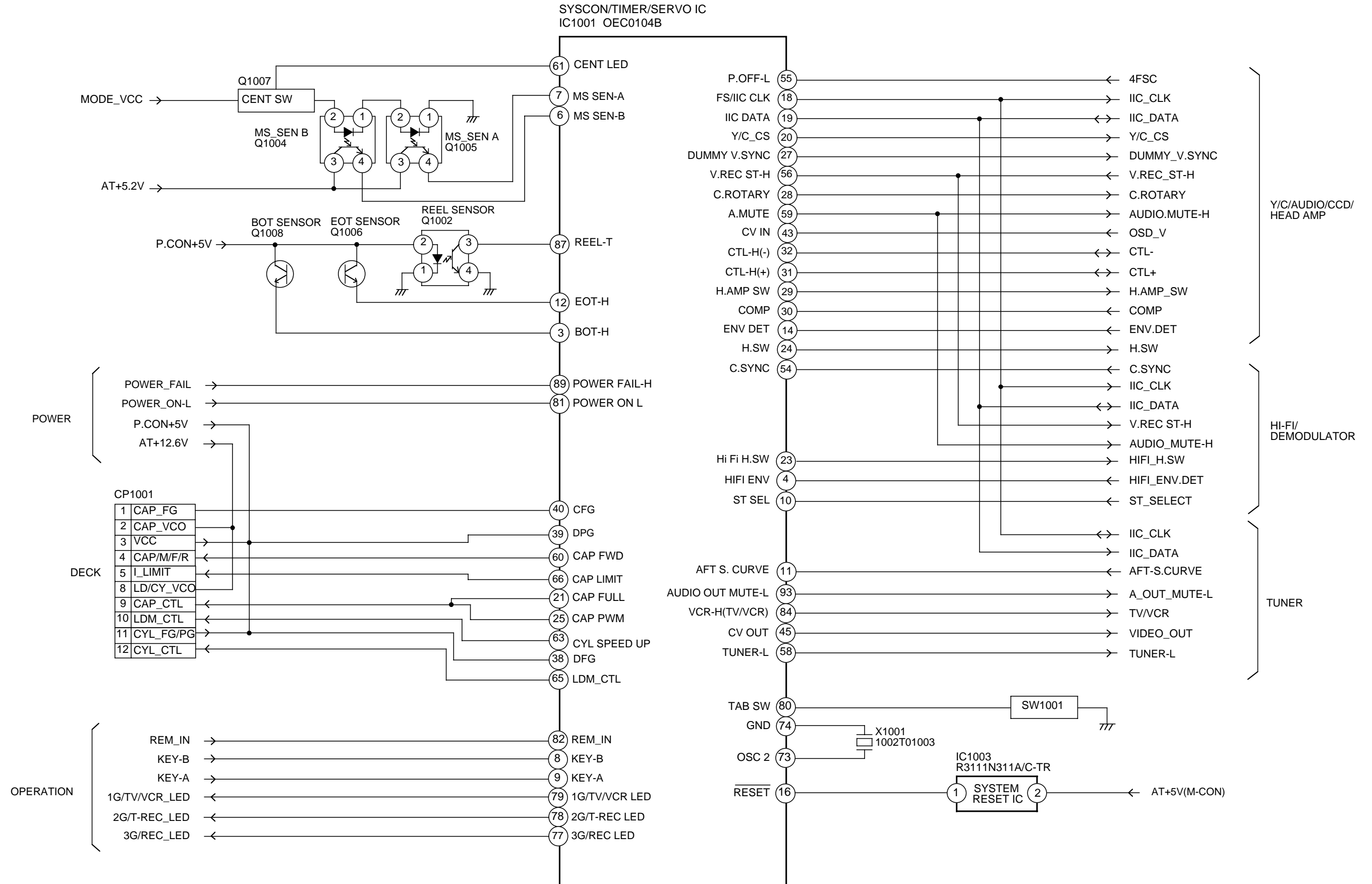

TUNER BLOCK DIAGRAM

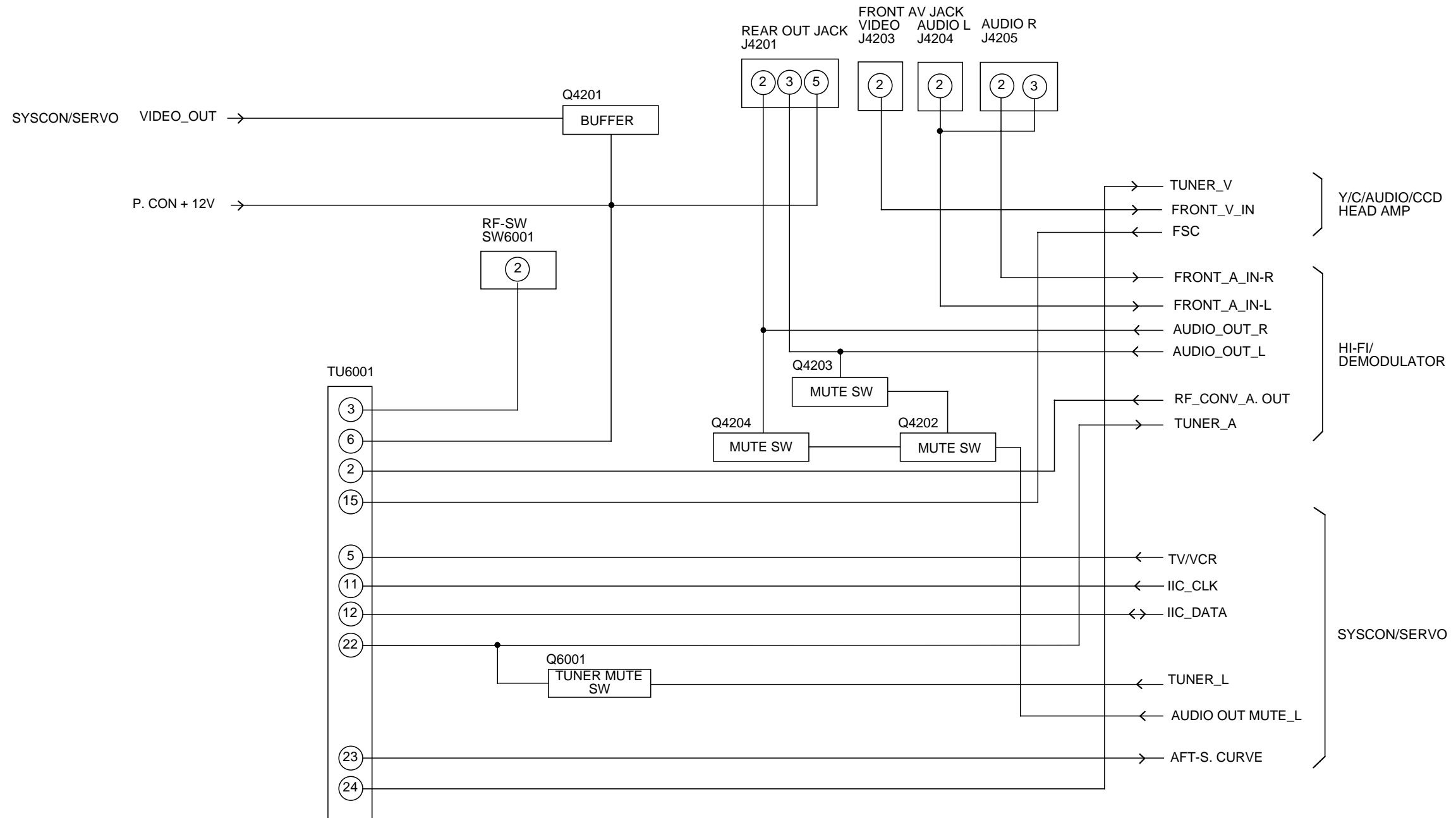

HI-FI/DEMODULATOR BLOCK DIAGRAM

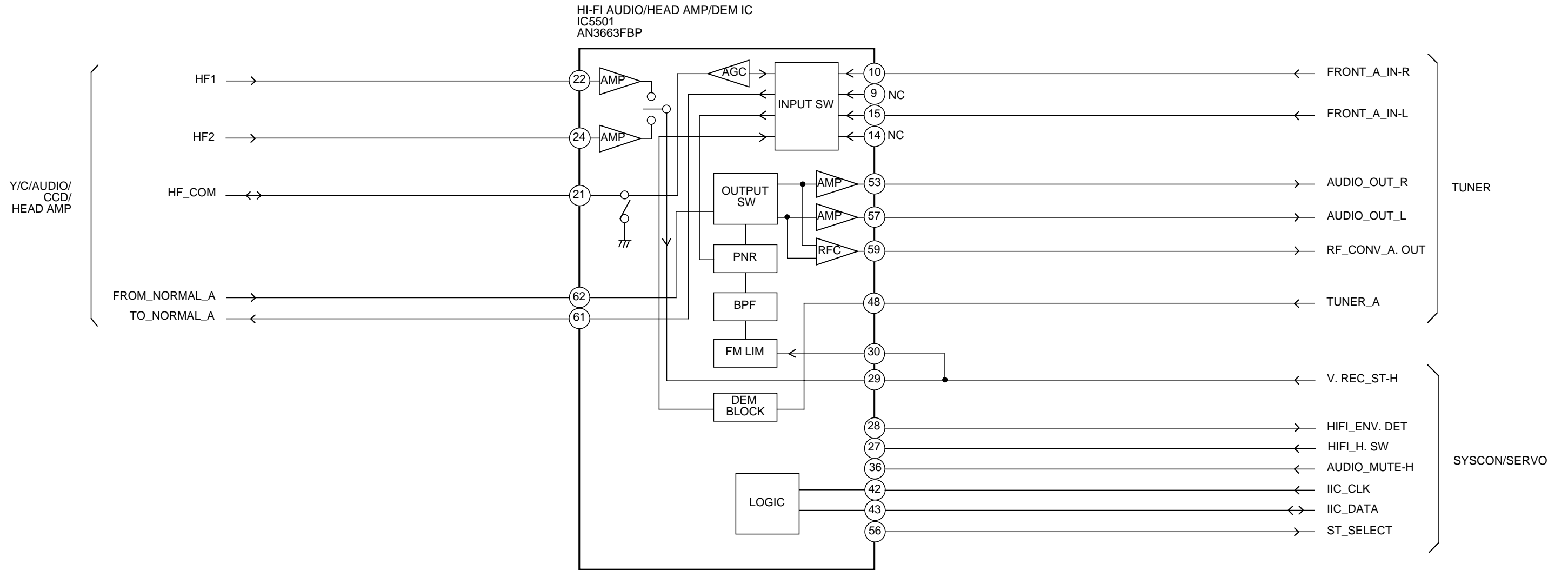

PRINTED CIRCUIT BOARDS
SYSCON/OPERATION (CHIP MOUNTED PARTS)
SOLDER SIDE

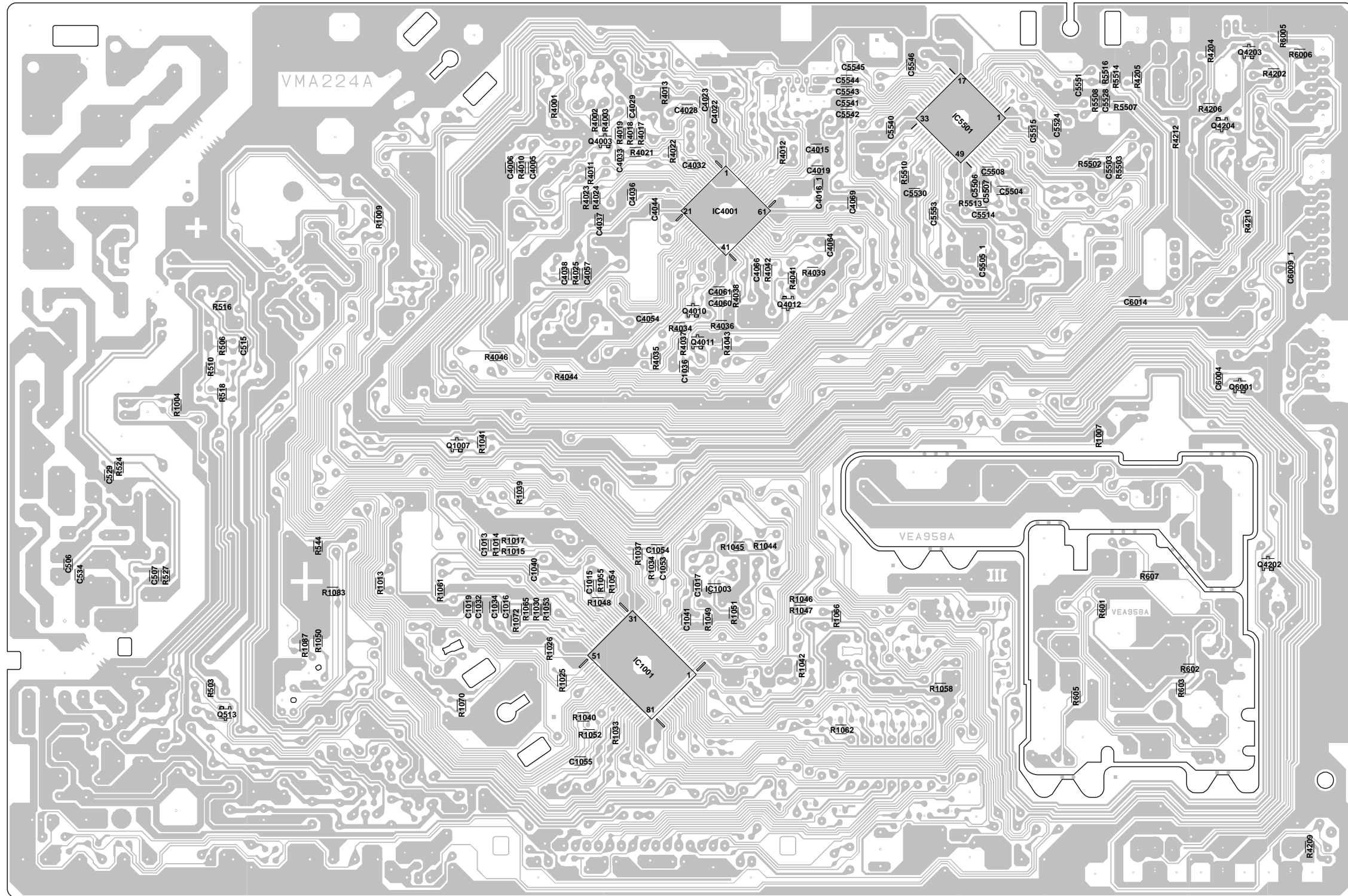

Y/C/AUDIO/CCD/HEAD AMP SCHEMATIC DIAGRAM (SYSCON PCB)

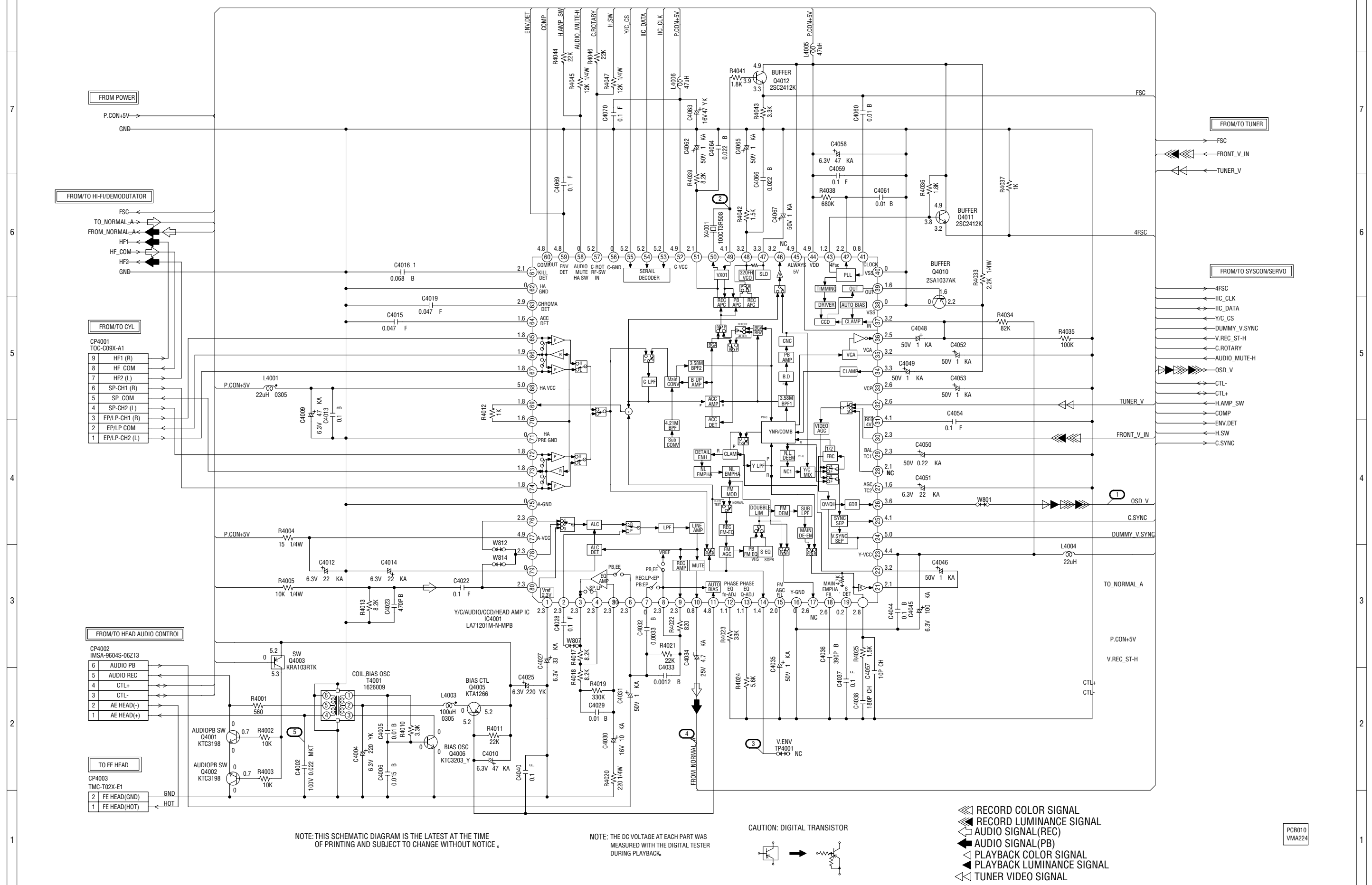

NOTE: THIS SCHEMATIC DIAGRAM IS THE LATEST AT THE TIME OF PRINTING AND SUBJECT TO CHANGE WITHOUT NOTICE.

NOTE: THE DC VOLTAGE AT EACH PART WAS MEASURED WITH THE DIGITAL TESTER DURING PLAYBACK.

CAUTION: DIGITAL TRANSISTOR

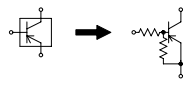

- ▶ RECORD COLOR SIGNAL
- ▶ RECORD LUMINANCE SIGNAL
- ▶ AUDIO SIGNAL (REC)
- ▶ AUDIO SIGNAL (PB)
- ▶ PLAYBACK COLOR SIGNAL
- ▶ PLAYBACK LUMINANCE SIGNAL
- ▶ TUNER VIDEO SIGNAL

PC8010
VMA224

SYSTEM CONTROL/SERVO SCHEMATIC DIAGRAM (SYSCON PCB)

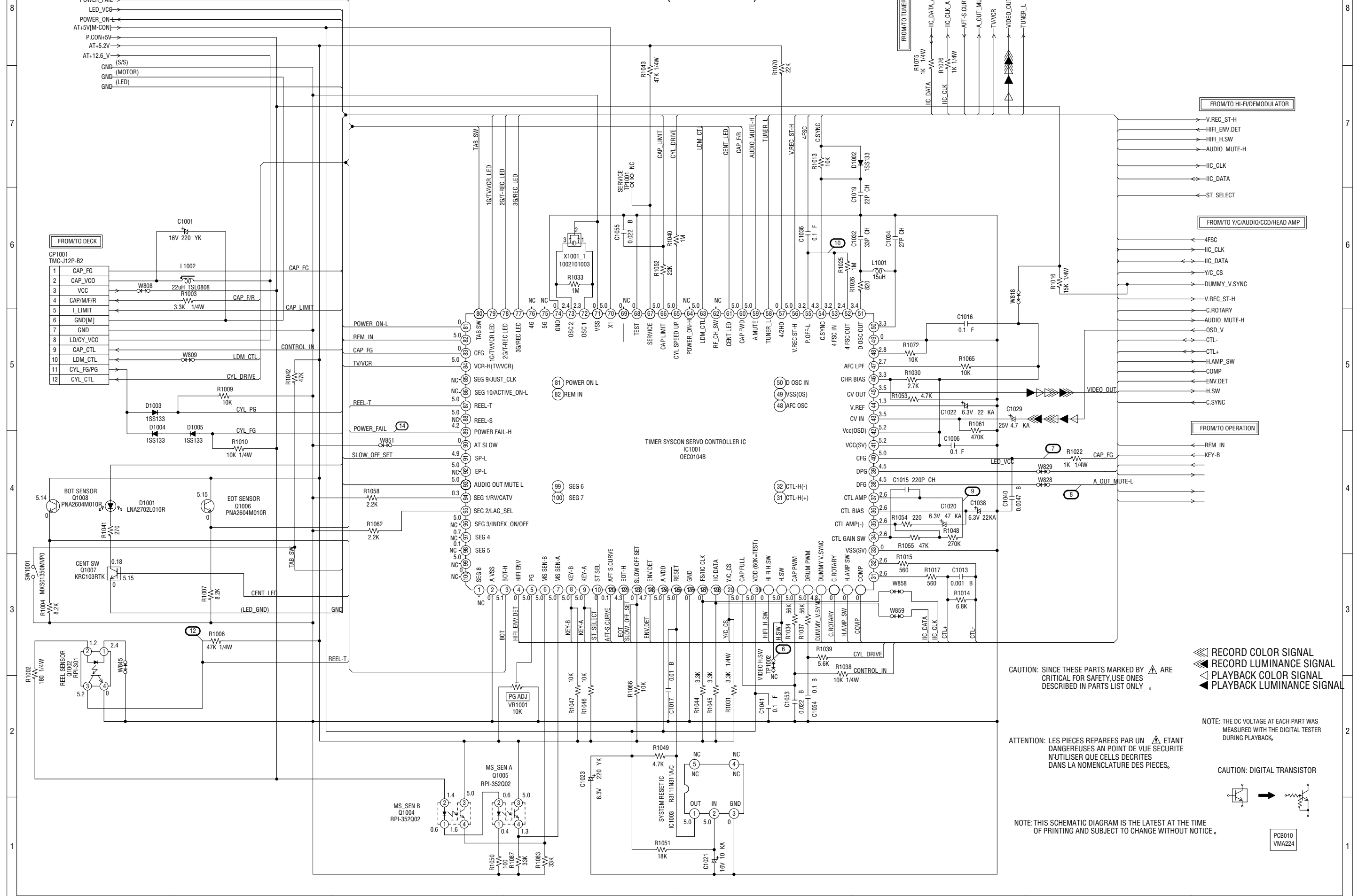

CAUTION: SINCE THESE PARTS MARKED BY ARE CRITICAL FOR SAFETY, USE ONES DESCRIBED IN PARTS LIST ONLY.

NOTE: THE DC VOLTAGE AT EACH PART WAS MEASURED WITH THE DIGITAL TESTER DURING PLAYBACK.

ATTENTION: LES PIÈCES RÉPARÉES PAR UN ÉTANT DANGEREUSES AN POINT DE VUE SÉCURITÉ N'UTILISER QUE CELLES DÉCRITES DANS LA NOMENCLATURE DES PIÈCES.

CAUTION: DIGITAL TRANSISTOR

NOTE: THIS SCHEMATIC DIAGRAM IS THE LATEST AT THE TIME OF PRINTING AND SUBJECT TO CHANGE WITHOUT NOTICE.

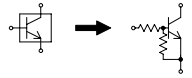

PCB010
VMA224

OPERATION SCHEMATIC DIAGRAM (SYSCON PCB)

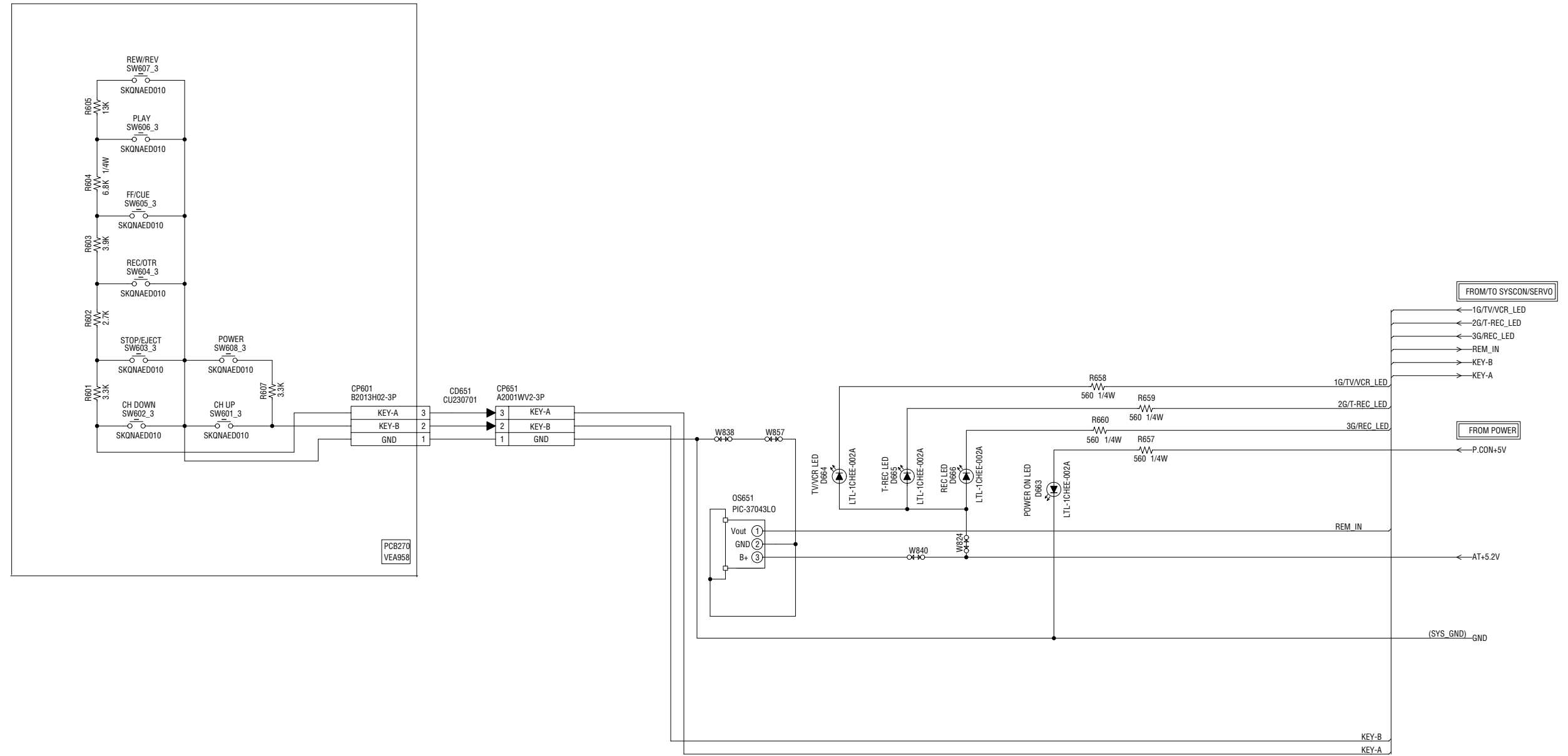

NOTE: THE DC VOLTAGE AT EACH PART WAS MEASURED WITH THE DIGITAL TESTER DURING PLAYBACK.

NOTE: THIS SCHEMATIC DIAGRAM IS THE LATEST AT THE TIME OF PRINTING AND SUBJECT TO CHANGE WITHOUT NOTICE.

PC8010
VMA224

TUNER SCHEMATIC DIAGRAM (SYSCON PCB)

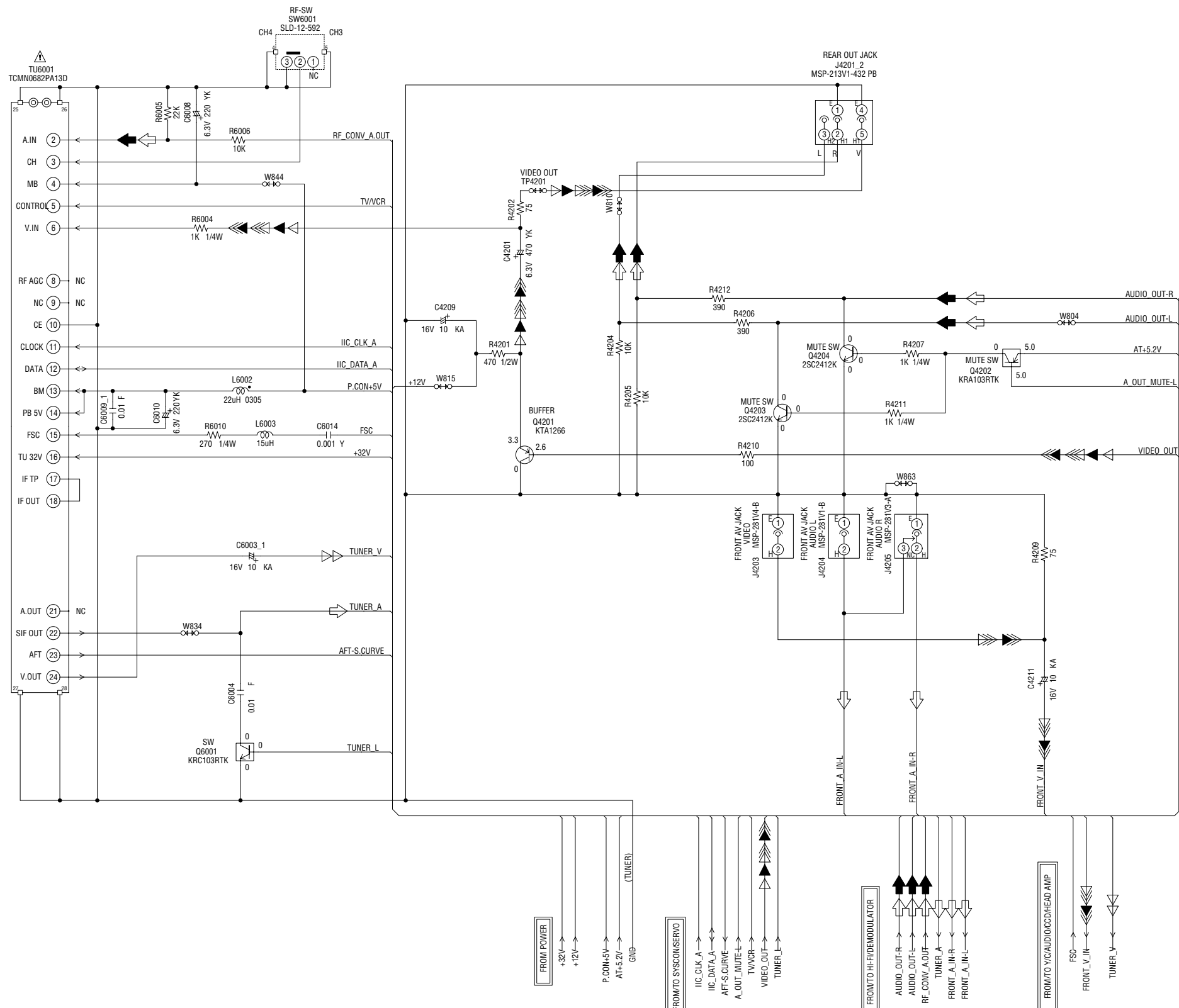

NOTE: THE DC VOLTAGE AT EACH PART WAS MEASURED WITH THE DIGITAL TESTER DURING PLAYBACK.

NOTE: THIS SCHEMATIC DIAGRAM IS THE LATEST AT THE TIME OF PRINTING AND SUBJECT TO CHANGE WITHOUT NOTICE.

CAUTION: SINCE THESE PARTS MARKED BY ARE CRITICAL FOR SAFETY, USE ONES DESCRIBED IN PARTS LIST ONLY.

ATTENTION: LES PIÈCES RÉPARÉES PAR UN ÉTANT DANGEREUSES AN POINT DE VUE SECURITE N'UTILISER QUE CELLS DÉCRITES DANS LA NOMENCLATURE DES PIÈCES.

CAUTION: DIGITAL TRANSISTOR

CAUTION: DIGITAL TRANSISTOR

- RECORD LUMINANCE SIGNAL
- RECORD COLOR SIGNAL
- AUDIO SIGNAL (REC)
- AUDIO SIGNAL (PB)
- TUNER VIDEO SIGNAL
- PLAYBACK LUMINANCE SIGNAL
- PLAYBACK COLOR SIGNAL

PCB010
VMA224

HI-FI/DEMODULATOR SCHEMATIC DIAGRAM (SYSCON PCB)

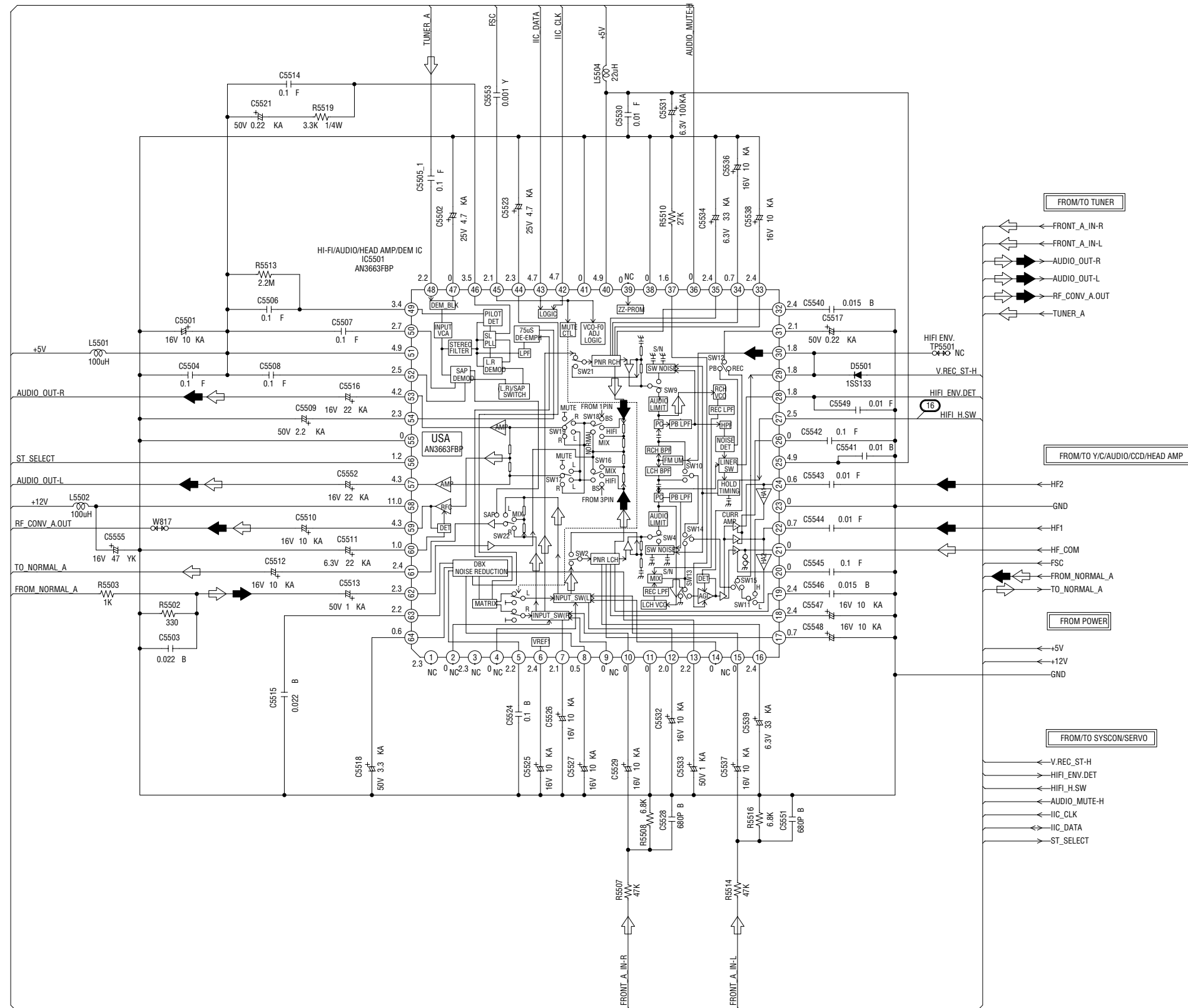

NOTE: THE DC VOLTAGE AT EACH PART WAS MEASURED WITH THE DIGITAL TESTER DURING PLAYBACK.

NOTE: THIS SCHEMATIC DIAGRAM IS THE LATEST AT THE TIME OF PRINTING AND SUBJECT TO CHANGE WITHOUT NOTICE.

◁ AUDIO SIGNAL (REC)
 ◀ AUDIO SIGNAL (PB)

PC8010
VMA224

INTERCONNECTION DIAGRAM

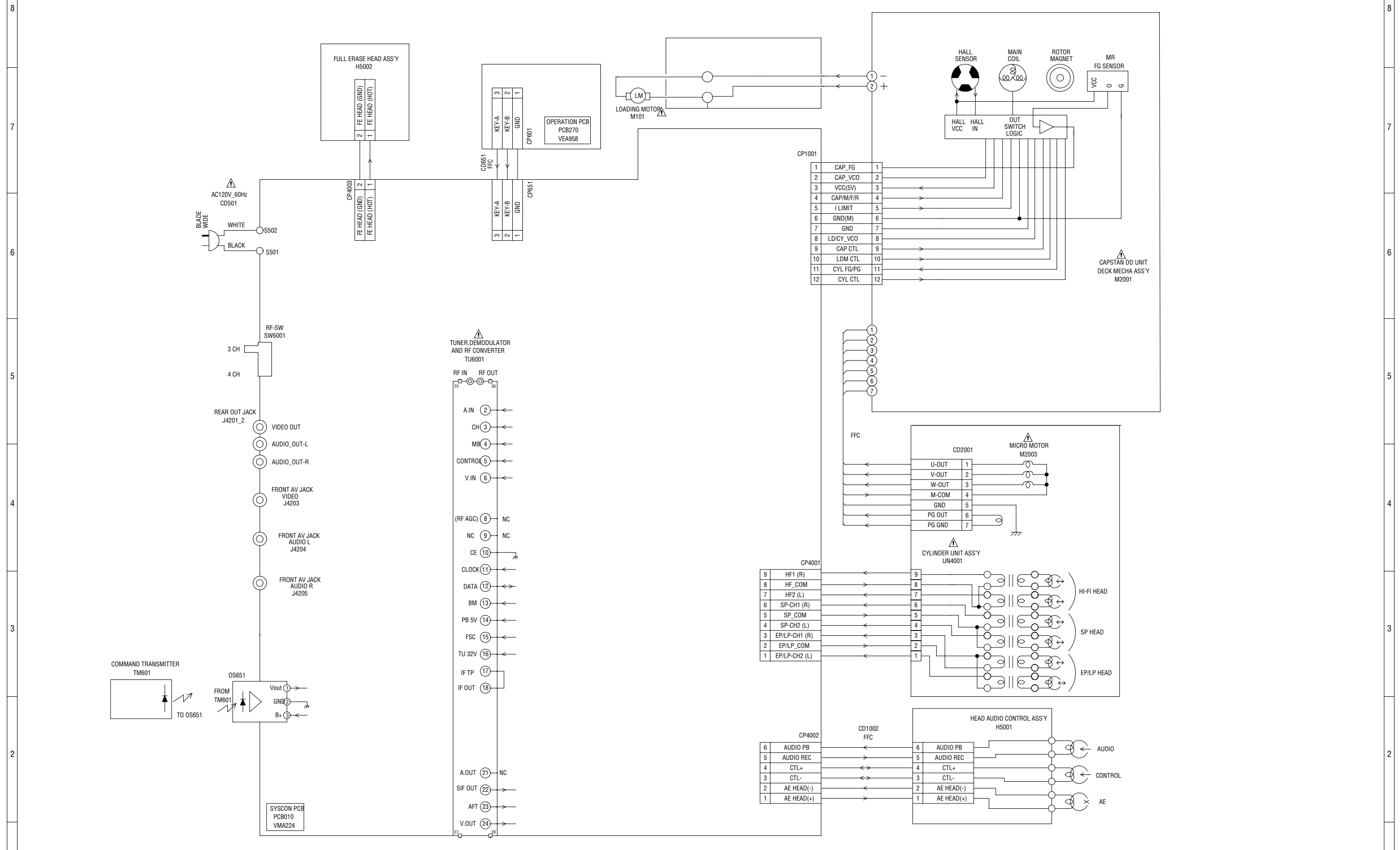

CAUTION: SINCE THESE PARTS MARKED BY ARE CRITICAL FOR SAFETY, USE ONES DESCRIBED IN PARTS LIST ONLY.

ATTENTION: LES PIÈCES RÉPARÉES PAR UN ÉTANT DANGEREUSES AU POINT DE VUE SÉCURITÉ, N'UTILISER QUE CELLES DÉCRITES DANS LA NOMENCLATURE DES PIÈCES.

NOTE: THIS INTERCONNECTION DIAGRAM IS THE LATEST AT THE TIME OF PRINTING AND SUBJECT TO CHANGE WITHOUT NOTICE.

WAVEFORMS

Y/C/AUDIO/CCD/HEAD AMP

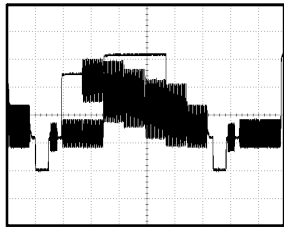

① POWER ON
10µs 500mV/div

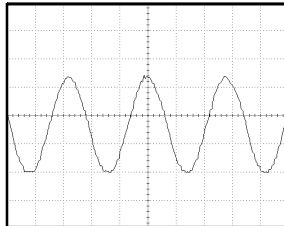

② POWER ON
100ns 100mV/div

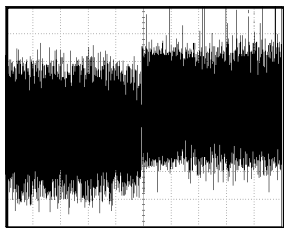

③ PB
1ms 100mV/div

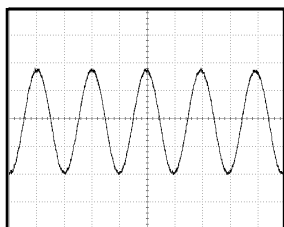

④ PB
500µs 200mV/div

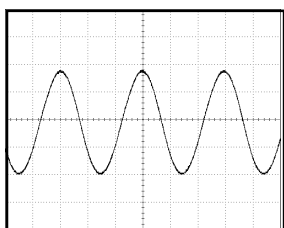

⑤ REC
5µs 20V/div

SYSCON/SERVO

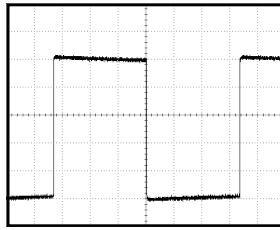

⑥ POWER ON
5ms 1.0V/div

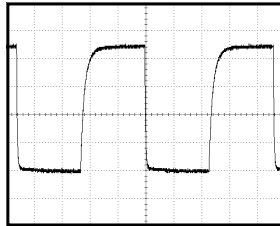

⑦ PB
2µs 1.0V/div

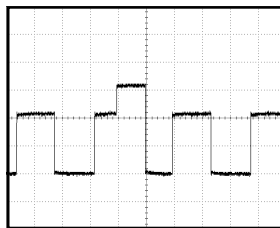

⑧ POWER ON
500µs 1.0V/div

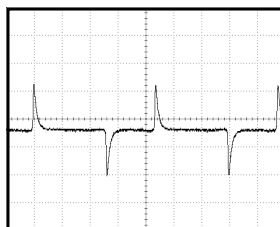

⑨ FF/REW
500µs 500mV/div

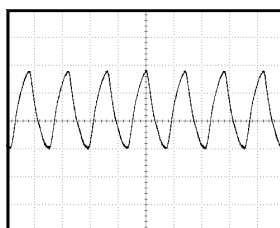

⑩ POWER ON
50ns 500mV/div

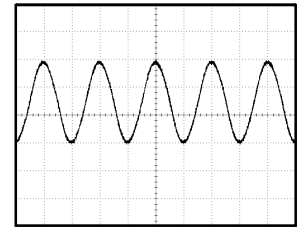

⑪ POWER ON
50ns 1.0V/div

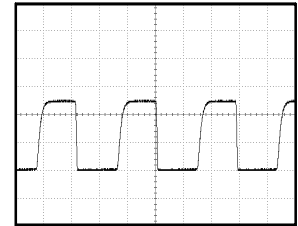

⑫ FF/REW
5ms 2V/div

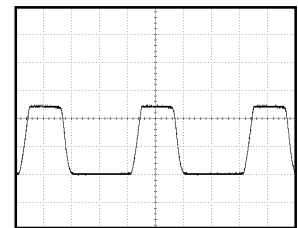

⑭ POWER OFF
5ms 2V/div

POWER

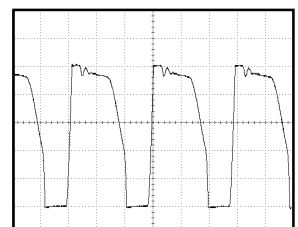

⑮ PB
2µs 50V/div

HI-FI/DEMODULATOR

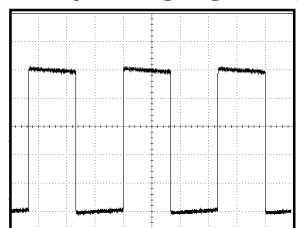

⑯ POWER ON
10ms 1.0V/div

NOTE: The following waveforms were measured at the point of the corresponding balloon number in the schematic diagram.

MECHANICAL EXPLODED VIEW

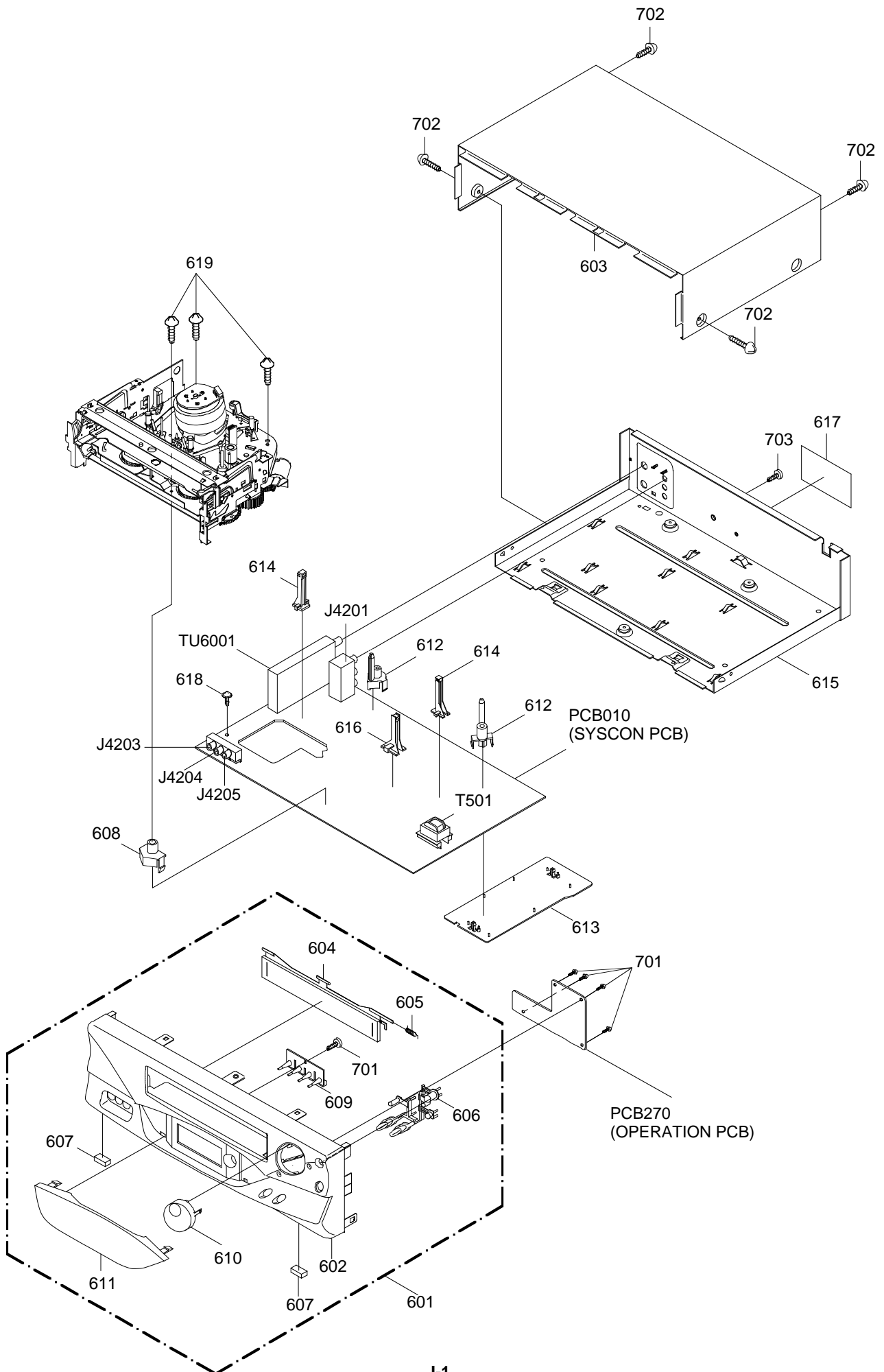

CHASSIS EXPLODED VIEW (TOP VIEW)

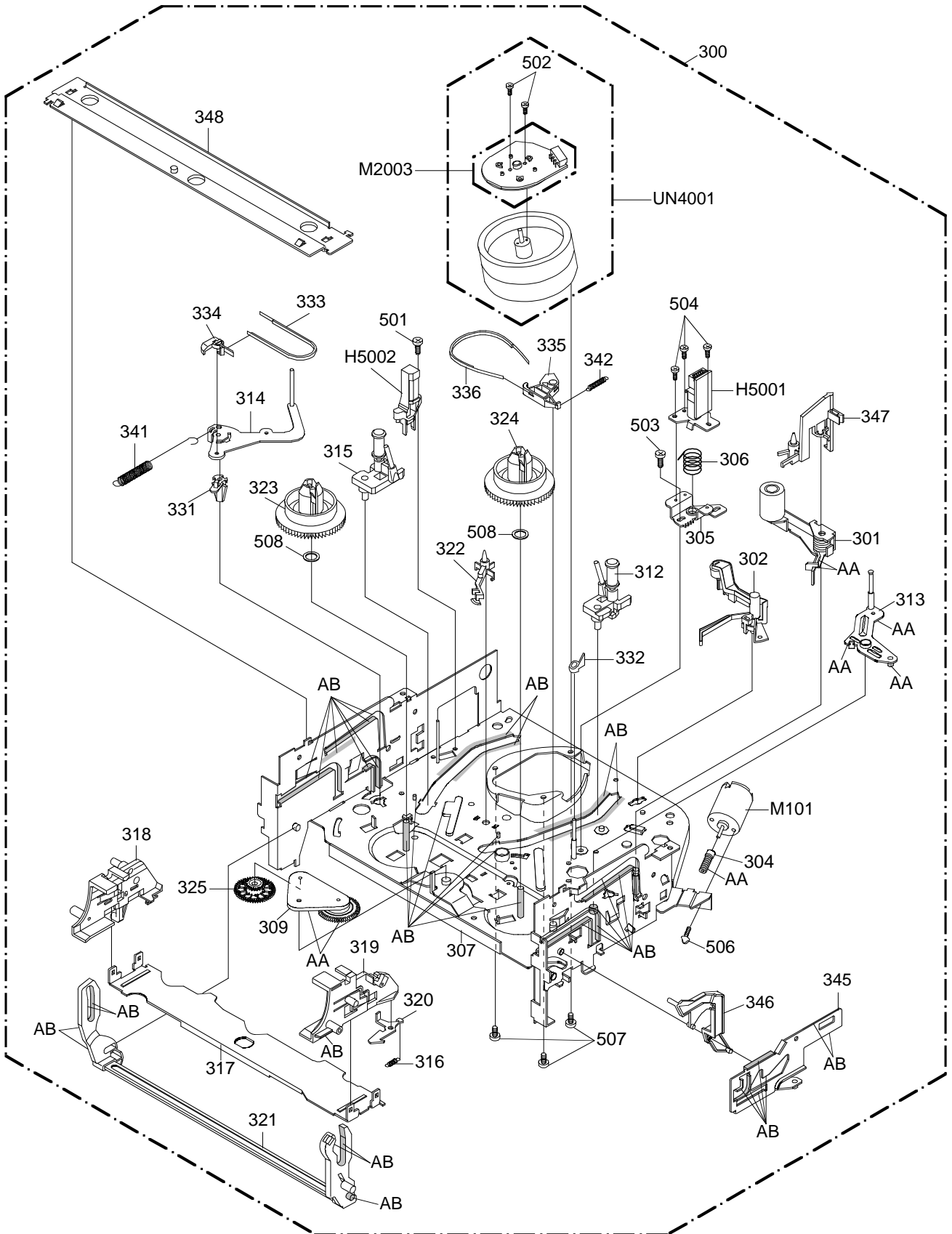

CLASS	PART NO.	MARK
GREASE	G-555G	AA
	MG-33	AB

NOTE: Applying positions AA and AB for the grease are displayed for this section. Check if the correct grease is applied for each position.

CHASSIS EXPLODED VIEW (BOTTOM VIEW)

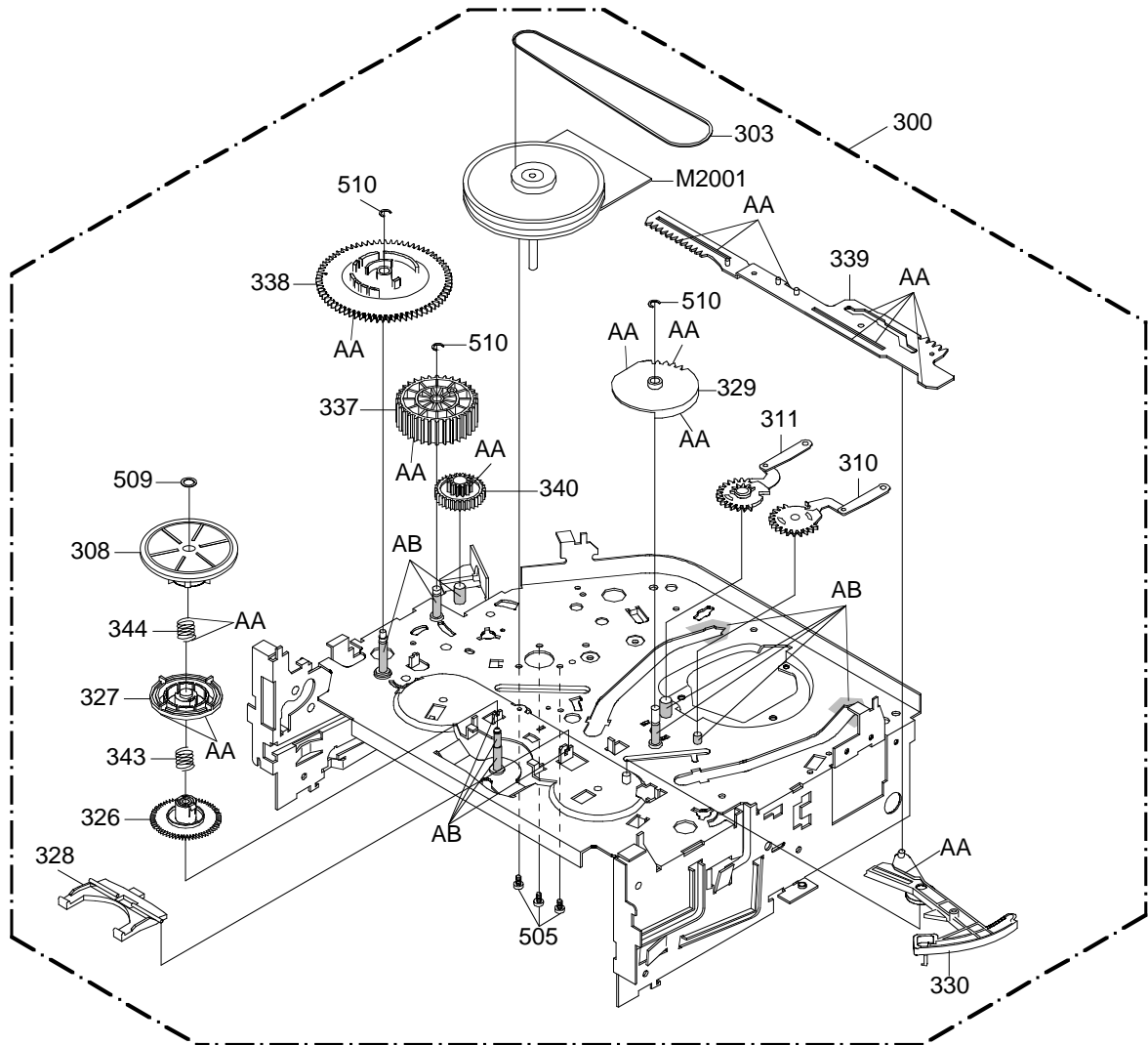

CLASS	PART NO.	MARK
GREASE	G-555G	AA
	MG-33	AB

NOTE: Applying positions AA and AB for the grease are displayed for this section. Check if the correct grease is applied for each position.

MECHANICAL REPLACEMENT PARTS LIST

REF. NO.	PART NO.	DESCRIPTION		
601	A4F213B720	CABINET,FRONT ASS'Y		
602	701WPJB416	CABINET,FRONT		
603	702WSB0058	CABINET,TOP		
604	712WPJB163	FLAP		
605	743WKA0032	SPRING,FLAP (COMBO)		
606	735WPAA216	BUTTON,FRAME		
607	800WFA0045	CUSHION,LEG		
608	701WPA0686	HOLDER,DECK		
609	713WPAA037	GLASS,LED		
610	735WPDA445	BUTTON,PLAY/STOP		
611	711WPDA389	PLATE,DISPLAY		
612	701WPA0680	HOLDER,DECK		
613	755WPA0020	PLATE,COVER POWER		
614	85OP700036	HOLDER,EOT SENSOR		
615	702WSA0083	PLATE,BOTTOM		
616	85OP700037	HOLDER,LED		
617	722A08A089	SHEET,RATING		
618	8109230704	SCREW,TAP TITE (B)R	BIND	3x7
619	8109130B94	SCREW,TAP TITE (B)R	PAN	3x29
701	8110226804	SCREW,TAP TITE (P)	BIND	2.6x8
702	8109230802	SCREW,TAP TITE (B)		3x8
703	8110230804	SCREW,TAP TITE (P)	BIND	3x8
---	JA5U0200	POLYBAG		
---	J3J81702	WARRANTY SHEET		
---	J4F21301	INSTRUCTION BOOK		
---	A4F213B975	INSTRUCTION BOOK KIT		
---	791WHA0095	GIFT,SHEET		
---	792WHA0306	PACKAGE		
---	793WCDB047	GIFT BOX		

CHASSIS REPLACEMENT PARTS LIST

REF. NO.	PART NO.	DESCRIPTION	REF. NO.	PART NO.	DESCRIPTION
300	A4F201B420K	DECK ASSY A4F201B420K	501	8107226804	SCREW,TAP TITE(S) BIND 2.6x8
			502	8107226504	SCREW,TAP TITE(S) BIND 2.6x5
301	85OA400227	PINCH ROLLER BLOCK	503	8107226404	SCREW,TAP TITE(S) BIND 2.6x4
302	85OA500026	AHC ASS'Y	504	8102120604	SCREW,PAN M2x6
303	85OP200290	BELT,CAPSTAN (S)	505	8109126604	SCREW,TAP TITE(B) PAN 2.6x6
304	85OP600581	WORM	506	810A130404	SCREW/WASHER(A) M3x4
305	85OP500083	BASE,AC HEAD	507	810A126504	SCREW/WASHER(A) M2.6x5
306	85OP800324	SPRING,AC HEAD	508	82Q264713N	POLYSLIDER WASHER 2.6x4.7xT0.13
307	85OA000459	MAIN CHASSIS ASS'Y	509	82P184505N	POLYSLIDER WASHER(CUT) 1.8x4.5xT0.5
308	85OA200089	CLUTCH ASS'Y			
309	85OA200090	ARM IDLER ASS'Y	510	83ETW30000	E-RING 3.0
310	85OA300065	LOADING ARM S UNIT	CD1501	122H071603	CORD JUMPER SMCD-7X151
311	85OA300066	LOADING ARM T UNIT	CD1502	122Y021902	CORD JUMPER 2Y021902
312	85OA400223	INCLINED BASE T UNIT 3S	H5001	1523D91034	HEAD (AUDIO CONTROL) HVMXA1072A
313	85OA400226	P5 ARM ASS'Y	H5002	1543D02013	HEAD (FULL ERASE) HVFHP0032A
314	85OA400230	TENSION ARM ASS'Y	△ M101	1596P98001	MOTOR (LOADING) MXN13FB12K3
315	85OA400231	INCLINED BASE S UNIT	△ M2001	1510S98035	CAPSTAN DD UNIT F2QVB01-C
316	85OP800358	SPRING,LOCKER	△ M2003	1589S11015	MICRO MOTOR I2OAL01
317	85OP900736	CASS,HOLDER	△ UN4001	A4F201B500	CYLINDER UNIT ASS'Y A4F201B500
318	85OP900737	CASS,SIDE L			
319	85OP900738	CASS,SIDE R			
320	85OP900739	LOCKER,R			
321	85OA900228	LINK UNIT			
322	85OP000496	POST,CASS GUIDE			
323	85OP200291	REEL,S (S)			
324	85OP200292	REEL,T (S)			
325	85OP200308	GEAR,IDLER			
326	85OP200311	GEAR,CLUTCH			
327	85OP200312	GEAR,COUPLING			
328	85OP200313	LEVER,CLUTCH			
329	85OP300194	GEAR,MAIN LOADING			
330	85OP400490	LEVER,TENSION			
331	85OP400492	HOLDER,TENSION			
332	85OP400520	CAP.P4			
333	85OP400532	BAND,TENSION			
334	85OP400533	CONNECT,TENSION			
335	85OP600573	ARM,BRAKE T			
336	85OP600574	BAND,BRAKE T			
337	85OP600577	CAM,PINCH ROLLER			
338	85OP600578	CAM,MAIN			
339	85OP600579	ROD,MAIN			
340	85OP600582	GEAR,JOINT			
341	85OP800322	SPRING,TENSION			
342	85OP800350	SPRING,BRAKE T			
343	85OP800355	SPRING,COUPLING			
344	85OP800356	SPRING,RING			
345	85OP900743	LEVER,LINK			
346	85OP900744	LEVER,FLAP			
347	85OP900745	CASS,OPENER			
348	85OP900746	BRACKET,TOP 3V			

ELECTRICAL REPLACEMENT PARTS LIST

REF. NO.	PART NO.	DESCRIPTION	REF. NO.	PART NO.	DESCRIPTION
RESISTORS			COILS & TRANSFORMERS		
△ R502	R0G3K2335K	RC 3.3M OHM 1/2W	△ L501	029T000083	COIL,LINE FILTER 0R3A433F20
△ R512	R002T2333J	RC 33K OHM 1/2W	L504	02167E220K	COIL 22 UH or
△ R514	R3X181010J	R,METAL OXIDE 1 OHM 1W		021W7A220K	COIL 22 UH
△ R547	R002T2224J	RC 220K OHM 1/2W	L505	02167E220K	COIL 22 UH or
△ R549	R65584331J	R,FUSE 330 OHM 1/4W		021W7A220K	COIL 22 UH
CAPACITORS			L1001	0216A6150K	COIL 15 UH
△ C504	P2472B223M	CMP 0.022 UF 275V PHE840	L1002	02167E220K	COIL 22 UH or
△ C505	CBLLYEMH3M	CC 0.0022UF 250V		021W7A220K	COIL 22 UH
△ C508	E62QFC470M	CE 47 UF 200V	L4001	02167F220J	COIL 22 UH
△ C514	E02LT0102M	CE 1000 UF 6.3V	L4003	02167F101J	COIL 100 UH
△ C518	E50HU5100M	CE 10 UF 50V	L4004	0216A6220K	COIL 22 UH
△ C519	E02LT2471M	CE 470 UF 16V	L4005	0216A6470K	COIL 47 UH
△ C520	E02LU0471M	CE 470 UF 6.3V	L4006	0216A6470K	COIL 47 UH
△ C522	E02LU2221M	CE 220 UF 16V	L5501	0216A6101K	COIL 100 UH
DIODES			L5502	0216A6101K	COIL 100 UH
D501	D97U02401B	DIODE,ZENER MTZJ24B T-77	L5504	0216A6220K	COIL 22 UH
D502	D1VT001330	DIODE,SILICON 1SS133T-77	L6002	02167F220J	COIL 22 UH
△ D505	D2WXN40050	DIODE SILICON 1N4005-EIC	L6003	0216A6150K	COIL 15 UH
D506	D1VT001330	DIODE,SILICON 1SS133T-77	△ T501	0481220094	TRANSFORMER,SWITCHING 8122009
△ D507	D1VT001330	DIODE,SILICON 1SS133T-77	T4001	031626009R	COIL,BIAS OSC 1626009
△ D508	D2WXN40050	DIODE,SILICON 1N4005-EIC	JACKS		
D511	D2WXGP10J0	DIODE,RECTIFIER RGP10J-EIC	J4201	060J411018	RCA,JACK MSP-213V1-432 PBSN
△ D512	D2WXS1400	DIODE,SCHOTTKY SB140-EIC	J4203	060J401079	RCA,JACK MSP-281V4-B
D513	D97U01301B	DIODE,ZENER MTZJ131B T-77	J4204	060J401080	RCA,JACK MSP-281V1-B
△ D514	D2WXB290S0	DIODE,SILICON SB290S	J4205	060J421023	RCA,JACK MSP-281V3-A
D520	D97U03301B	DIODE,ZENER MTZJ33B T-77	SWITCHES		
△ D521	D17T002440	DIODE,SILICON 1SS244T-77	SW601	0504201T32	SWITCH,TACT SKQNAED010
△ D523	D2WXN40050	DIODE,SILICON 1N4005-EIC	SW602	0504201T32	SWITCH,TACT SKQNAED010
D524	D1VT001330	DIODE,SILICON 1SS133T-77	SW603	0504201T32	SWITCH,TACT SKQNAED010
△ D525	D97U06R81B	DIODE,ZENER MTZJ6.8B T-77	SW604	0504201T32	SWITCH,TACT SKQNAED010
△ D528	D2WXN40050	DIODE,SILICON 1N4005-EIC	SW605	0504201T32	SWITCH,TACT SKQNAED010
D663	0021E2Q140	LED LTL-1CHEE-002A	SW606	0504201T32	SWITCH,TACT SKQNAED010
D664	0021E2Q140	LED LTL-1CHEE-002A	SW607	0504201T32	SWITCH,TACT SKQNAED010
D665	0021E2Q140	LED LTL-1CHEE-002A	SW608	0504201T32	SWITCH,TACT SKQNAED010
D666	0021E2Q140	LED LTL-1CHEE-002A	SW1001	0508A11001	SWITCH(LEAF) MXS01350MVP0
D1001	0010100320	INFRARED LED LNA2702L010R	SW6001	0510S21041	SWITCH SLIDE SLD-12-592
D1002	D1VT001330	DIODE,SILICON 1SS133T-77	VARIABLE RESISTOR		
D1003	D1VT001330	DIODE,SILICON 1SS133T-77	VR1001	V116314BTC	VOLUME,SEMI FIXED EVNVCYAA03B14
D1004	D1VT001330	DIODE,SILICON 1SS133T-77	P.C.BOARD ASSEMBLIES		
D1005	D1VT001330	DIODE,SILICON 1SS133T-77	PCB010	A4F213B010	PCB ASSY VMA224A
D5501	D1VT001330	DIODE,SILICON 1SS133T-77	PCB270	A4F213B270	PCB ASSY VEA958A
ICs			MISCELLANEOUS		
△ IC501	I1KJ9A4310	IC KIA431	B501	024HT03564	CORE,BEADS W4BRH3.5X6X1
IC505	0002E00610	PHOTO COUPLER LTV-817M-VB	B502	024HT03564	CORE,BEADS W4BRH3.5X6X1
IC511	0002E00610	PHOTO COUPLER LTV-817M-VB	△ CD501	120R414901	CORD,AC BUSH 0R414901
IC1001	I54F50104B	IC OEC0104B	CD651	06CU230701	CORD,JUMPER CU230701
IC1003	IC7J0311A0	IC R3111N311A/C-TR	CP601	067U003029	WIRE HOLDER B2013H02-3P
IC4001	I03F301MN0	IC LA71201M-N-MPB	CP651	069S230629	CONNECTOR PCB SIDE A2001VV2-3P
IC5501	I01F63FBP0	IC AN3663FBP	CD1002	122F061501	CORD,JUMPER 2F061501
TRANSISTORS			CD6002	06CQL02006	CABLE SI-C108-40
△ Q502	TD3T007340	TRANSISTOR,SILICON 2SD734(E,F)-AA	CP1001	06972C0010	CONNECTOR PCB SIDE TMC-J12P-B2
△ Q503	TCWQ4160E0	TRANSISTOR,SILICON 2SC4160-OEC-YAC1	CP4001	0697290620	CONNECTOR PCB SIDE TOC-C09X-A1
△ Q509	TCAT03205Y	TRANSISTOR,SILICON KTC3205_Y-AT	CP4002	069J760019	CONNECTOR PCB SIDE IMSA-9604S-06Z13
△ Q512	TCAT032034	TRANSISTOR,SILICON KTC3203_Y-AT or	CP4003	0697120320	CONNECTOR PCB SIDE TMC-T02X-E1
	TC5T021204	TRANSISTOR,SILICON 2SC2120Y(TPE2)	△ F501	081PC1R605	FUSE 51MS016L
Q513	TNAAC05002	COMPOUND TRANSISTOR KRC103RTK	FH501	06710T0006	HOLDER,FUSE EYF-52BC
△ Q515	TCATC31980	TRANSISTOR,SILICON KTC3198-AT(Y,GR)	FH502	06710T0006	HOLDER,FUSE EYF-52BC
Q1002	0002700590	PHOTO COUPLER RPI-301	OS651	077Q037001	REMOTE RECEIVER PIC-37043LO
Q1004	0002700670	PHOTO COUPLER RPI-352Q02	TM601	076N0EA040	TRANSMITTER RC-EA040
Q1005	0002700670	PHOTO COUPLER RPI-352Q02	△ TU6001	0162K00021	RF,UNIT TCMN0682PA13D
Q1006	0000100380	PHOTO TRANSISTOR PNA2604M010R	X1001	1002T01003	CERAMIC OSCILLATOR CSTS1000MG96004-T2
Q1007	TNAAC05002	COMPOUND TRANSISTOR KRC103RTK	X4001	100CT3R508	CRYSTAL HC-49/U 3.579545MHz
Q1008	0000100380	PHOTO TRANSISTOR PNA2604M010R	RESISTOR		
Q4001	TCATC31980	TRANSISTOR,SILICON KTC3198-AT(Y,GR)	RC..... CARBON RESISTOR		
Q4002	TCATC31980	TRANSISTOR,SILICON KTC3198-AT(Y,GR)	CAPACITORS		
Q4003	TPAAC05002	COMPOUND TRANSISTOR KRA103RTK	CC..... CERAMIC CAPACITOR		
Q4005	TAATA12660	TRANSISTOR,SILICON KTA1266-AT(Y,GR)	CE..... ALUMI ELECTROLYTIC CAPACITOR		
Q4006	TCAT032034	TRANSISTOR,SILICON KTC3203_Y-AT or	CP..... POLYESTER CAPACITOR		
	TC5T021204	TRANSISTOR,SILICON 2SC2120Y(TPE2)	CPP..... POLYPROPYLENE CAPACITOR		
Q4010	T6YJ1037K0	TRANSISTOR,SILICON 2SA1037AKT146R,S	CPL..... PLASTIC CAPACITOR		
Q4011	T8YJ2412K0	TRANSISTOR,SILICON 2SC2412KT146 R,S	CMP..... METAL POLYESTER CAPACITOR		
Q4012	T8YJ2412K0	TRANSISTOR,SILICON 2SC2412KT146 R,S	CML..... METAL PLASTIC CAPACITOR		
Q4201	TAATA12660	TRANSISTOR,SILICON KTA1266-AT(Y,GR)	CMPP..... METAL POLYPROPYLENE CAPACITOR		
Q4202	TPAAC05002	COMPOUND TRANSISTOR KRA103RTK			
Q4203	T8YJ2412K0	TRANSISTOR,SILICON 2SC2412KT146 R,S			
Q4204	T8YJ2412K0	TRANSISTOR,SILICON 2SC2412KT146 R,S			
Q6001	TNAAC05002	COMPOUND TRANSISTOR KRC103RTK			

SPEC.NO.	M4F2-13B
O/R NO.	K184001



MVR4051

SERVICE MANUAL

VIDEO CASSETTE RECORDER

**REVISION 1
MFR'S VERSION C, D**



MFR'S VERSION	TU6001	PRODUCT IMPROVEMENT
B	TCMN0682PA13D	ORIGINAL
C	TCMN0682PA13D(3)	Change of TAPE EJECT TIMMING
D	TADC-H218F	

Change of TAPE EJECT TIMMING

CHASSIS REPLACEMENT PARTS LIST

REF. NO.	MFR'S VERSION B		MFR'S VERSION C	
	PART NO.	DESCRIPTION	PART NO.	DESCRIPTION
345	85OP900743	LEVER, LINK	85OP900750	LEVER, LINK 2

Change of TU6001

ELECTRICAL REPLACEMENT PARTS LIST

REF. NO.	MFR'S VERSION B		MFR'S VERSION C	
	PART NO.	DESCRIPTION	PART NO.	DESCRIPTION
△ TU6001	0162K00021	RF UNIT TCMN0682PA13D	0162K00025	RF UNIT TCMN0682PA13D(3)
PCB010	A4F213B010	SYSCON PCB ASS'Y (VERSION B) VMA224A	A4F210B010	SYSCON PCB ASS'Y (VERSION C) VMA224A

SYSCON PCB's are interchangeable.

REF. NO.	MFR'S VERSION C		MFR'S VERSION D	
	PART NO.	DESCRIPTION	PART NO.	DESCRIPTION
△ TU6001	0162K00025	RF UNIT TCMN0682PA13D(3)	0162Y00026	RF UNIT TADC-H218F
C6004	CS0RF0414Z	CC 0.01 UF 50V F		DEL
Q6001	TNAAC05002	COMPOUND TRANSISTOR KRC103SRTK		DEL
CUS011			800WFAA008	CUSHION C
PCB010	A4F210B010	SYSCON PCB ASS'Y (VERSION C) VMA224A	A4F210B010	SYSCON PCB ASS'Y (VERSION D) VMA224A

SYSCON PCB's are interchangeable.

PRINTED CIRCUIT BOARDS
SYSCON/OPERATION (INSERTED PARTS)
SOLDER SIDE

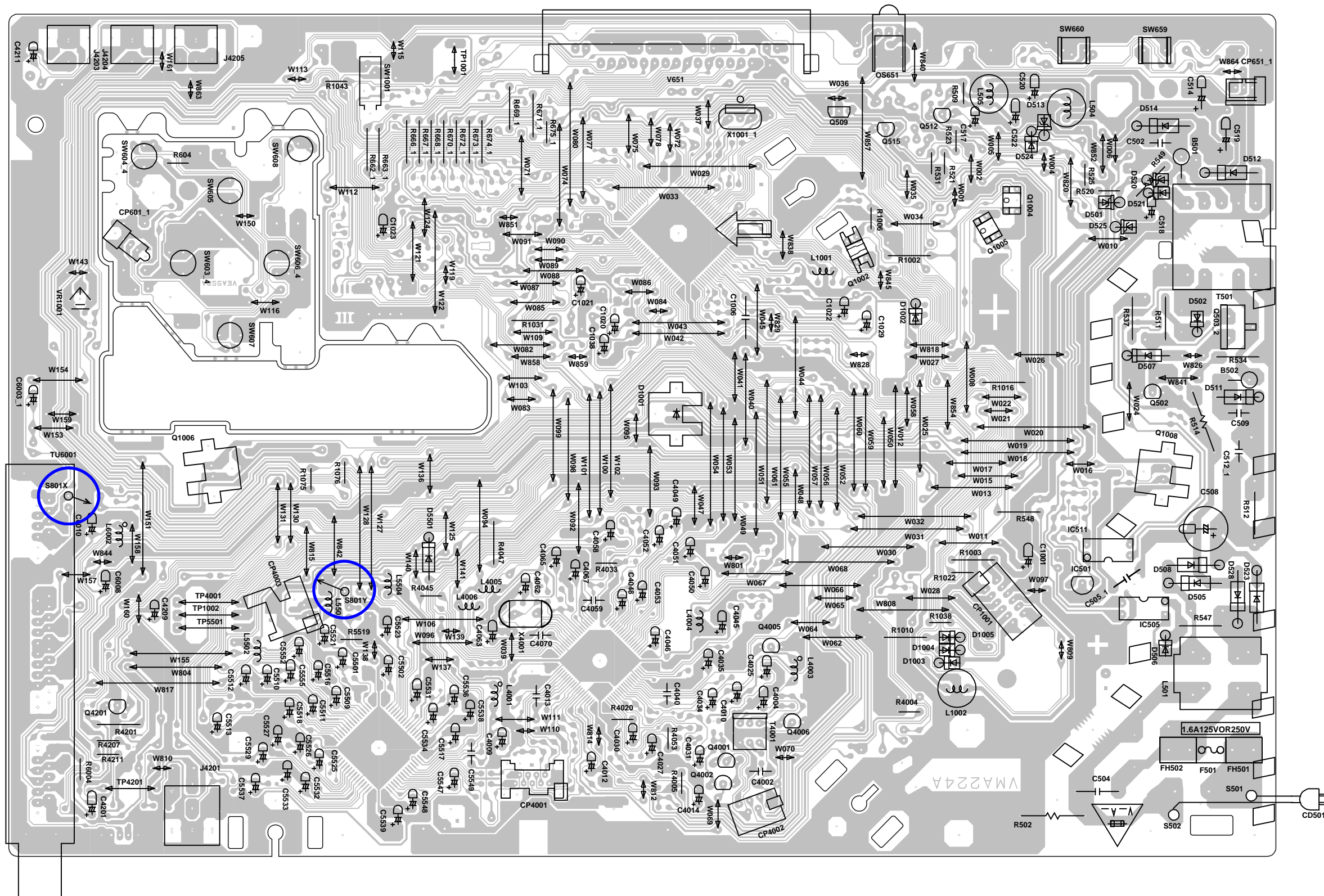

ADD: S801X, S801Y

TUNER SCHEMATIC DIAGRAM (SYSCON PCB)

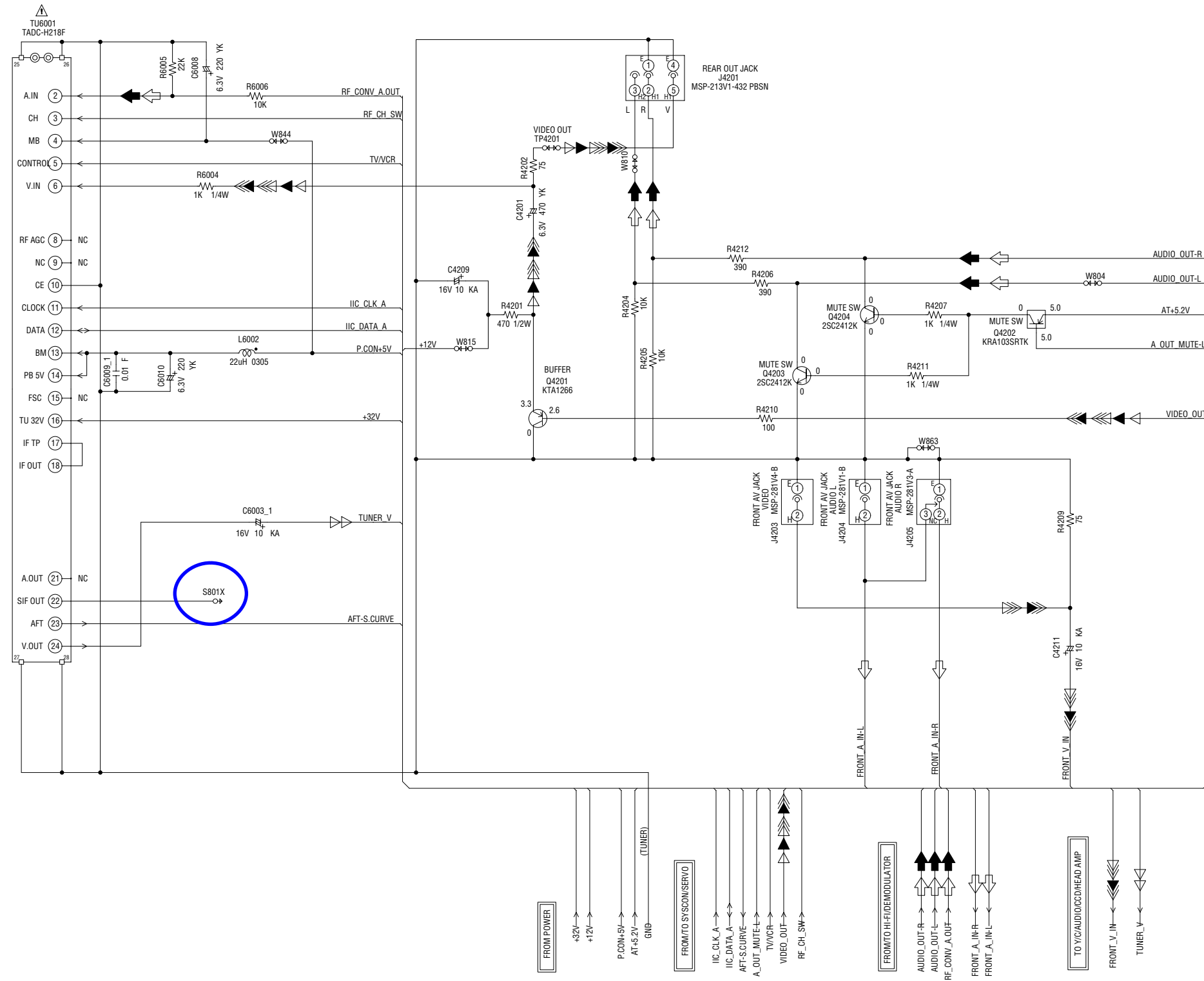

CAUTION: DIGITAL TRANSISTOR

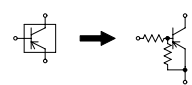

NOTE: THE DC VOLTAGE EACH PART WAS MEASURED WITH THE DIGITAL TESTER DURING PLAYBACK.

NOTE: THIS SCHEMATIC DIAGRAM IS THE LATEST AT THE TIME OF PRINTING AND SUBJECT TO CHANGE WITHOUT NOTICE.

CAUTION: SINCE THESE PARTS MARKED BY ARE CRITICAL FOR SAFETY, USE ONES DESCRIBED IN PARTS LIST ONLY.

ATTENTION: LES PIECES REPARÉES PAR UN ETANT DANGEREUSES AN POINT DE VUE SECURITE N'UTILISER QUE CELLS DECRITES DANS LA NOMENCLATURE DES PIECES.

- RECORD LUMINANCE SIGNAL
- RECORD COLOR SIGNAL
- AUDIO SIGNAL (REC)
- AUDIO SIGNAL (PB)
- TUNER VIDEO SIGNAL
- PLAYBACK LUMINANCE SIGNAL
- PLAYBACK COLOR SIGNAL

PC8010
VMA224

ADD: S801X

HI-FI/DEMODULATOR SCHEMATIC DIAGRAM (SYSCON PCB)

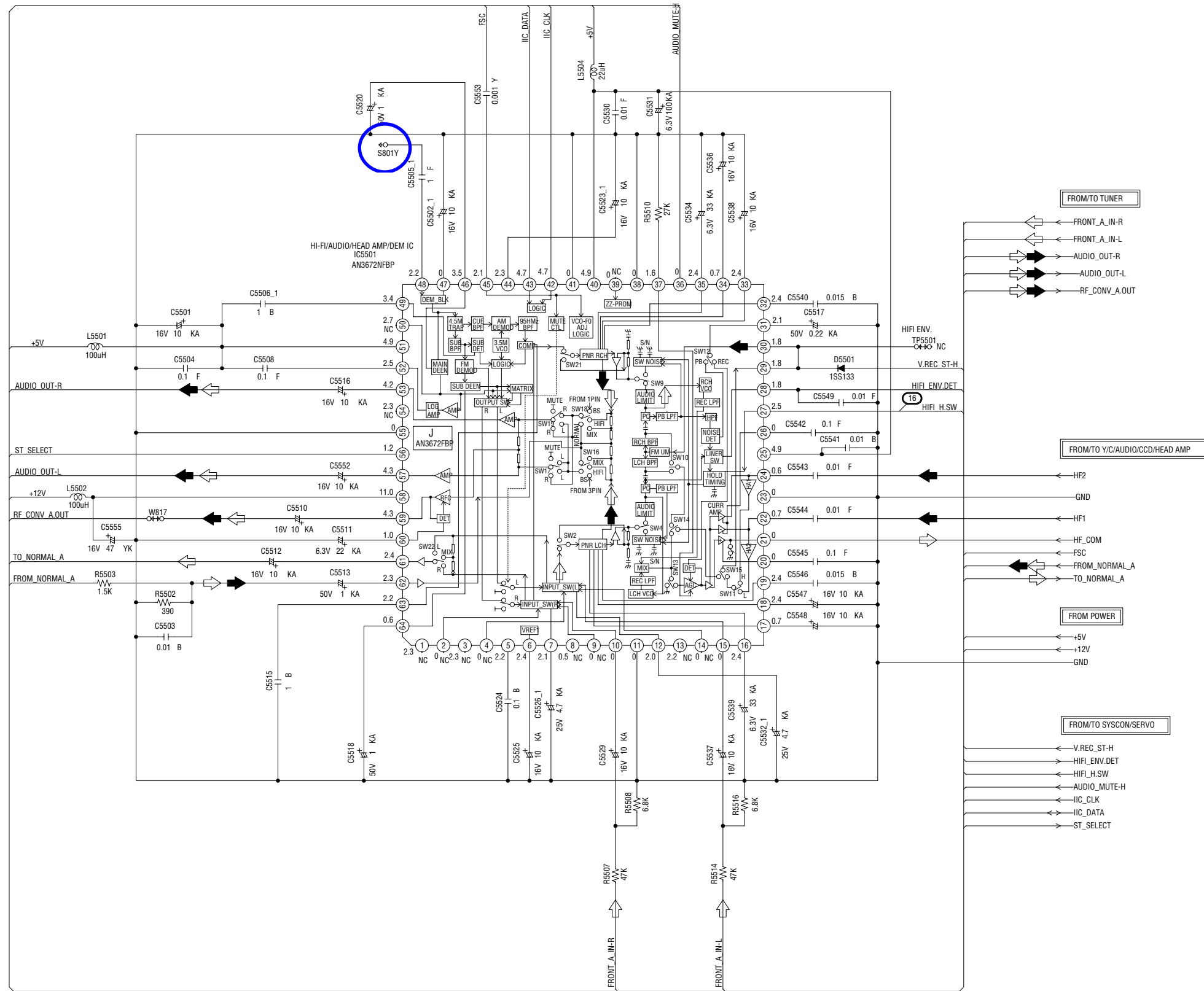

NOTE: THE DC VOLTAGE AT EACH PART WAS MEASURED WITH THE DIGITAL TESTER DURING PLAYBACK.

NOTE: THIS SCHEMATIC DIAGRAM IS THE LATEST AT THE TIME OF PRINTING AND SUBJECT TO CHANGE WITHOUT NOTICE.

◀ AUDIO SIGNAL(REC)
▶ AUDIO SIGNAL(PB)

ADD: S801Y

PCB010
VMA224

SPEC.NO.	M4F2-37B
O/R NO.	K244018, K264029